

**ACADEMIC REGULATIONS  
COURSE STRUCTURE  
AND  
DETAILED SYLLABI  
OF  
CIVIL ENGINEERING  
FOR  
B.TECH REGULAR FOUR YEAR DEGREE PROGRAM  
*(For the batches admitted from 2019-2020)*  
&  
FOR B.TECH LATERAL ENTRY PROGRAM  
*(For the batches admitted from 2020-2021)*  
CHOICE BASED CREDIT SYSTEM**



**SREE VIDYANIKETHAN ENGINEERING COLLEGE (AUTONOMOUS)**

**(Affiliated to JNTUA, Ananthapuramu, Approved by AICTE, Programs Accredited by NBA,  
Accredited by NAAC with 'A' grade)  
SREE SAINATH NAGAR, A. Rangampet -517102:: NEAR TIRUPATI (A.P)**

## **VISION**

To be one of the Nation's premier Engineering Colleges by achieving the highest order of excellence in Teaching and Research.

## **MISSION**

- To foster intellectual curiosity, pursuit and dissemination of knowledge.
- To explore students' potential through academic freedom and integrity.
- To promote technical mastery and nurture skilled professionals to face competition in ever increasing complex world.

## **QUALITY POLICY**

Sree Vidyanikethan Engineering College strives to establish a system of Quality Assurance to continuously address, monitor and evaluate the quality of education offered to students, thus promoting effective teaching processes for the benefit of students and making the College a Centre of Excellence for Engineering and Technological studies.

## **DEPARTMENT OF CIVIL ENGINEERING**

### **VISION**

To become a leading centre of excellence in the country in Civil Engineering education through teaching, research, consultancy and public service for technical development in a knowledge society.

### **MISSION**

- Inspire the civil engineers of tomorrow to take on the challenges of creating and sustaining the built environment that support our society.
- Nurture these civil engineers with fundamental engineering knowledge, a broad set of skills, and an inquisitive attitude for creating innovative solutions to serve industry and community through contemporary curriculum, congenial learning environment, pertinent research, industry-institute interaction, mentoring, co-curricular and extra-curricular activities.
- Encourage faculty and staff to excel in their respective fields and demonstrate the best of their abilities by way of continuing education, research and consultancy.

## **PROGRAM EDUCATIONAL OBJECTIVES**

After few years of graduation, the graduates of B.Tech. (CE) will:

1. Pursue higher education in civil engineering or other fields of engineering or management or other areas of interest.
2. Address the contemporary issues in Civil Engineering or related field and provide appropriate solutions through professional career in industry/teaching/research.
3. Engage in 'technology innovation and deployment' and engineering system implementation, as an entrepreneur.
4. Exhibit leadership qualities, participate in continuing education programmes for lifelong learning and contribute individually and as a member in multidisciplinary teams to meet social and ethical constraints.

## **PROGRAM OUTCOMES**

On successful completion of the Program, the graduates of B.Tech. (CE) program will be able to:

1. Apply the knowledge of mathematics, science, engineering fundamentals, and an engineering specialization to the solution of complex engineering problems. **(Engineering knowledge)**
2. Identify, formulate, review research literature, and analyze complex engineering problems reaching substantiated conclusions using first principles of mathematics, natural sciences, and engineering sciences. **(Problem analysis)**
3. Design solutions for complex engineering problems and design system components or processes that meet the specified needs with appropriate consideration for the public health and safety, and the cultural, societal, and environmental considerations. **(Design/development of solutions)**
4. Use research-based knowledge and research methods including design of experiments, analysis and interpretation of data, and synthesis of the information to provide valid conclusions. **(Conduct investigations of complex problems)**

5. Create, select, and apply appropriate techniques, resources, and modern engineering and IT tools including prediction and modeling to complex engineering activities with an understanding of the limitations. **(Modern tool usage)**
6. Apply reasoning informed by the contextual knowledge to assess societal, health, safety, legal and cultural issues and the consequent responsibilities relevant to the professional engineering practice. **(The engineer and society)**
7. Understand the impact of the professional engineering solutions in societal and environmental contexts, and demonstrate the knowledge of, and need for sustainable development). **(Environment and sustainability)**
8. Apply ethical principles and commit to professional ethics and responsibilities and norms of the engineering practice. **(Ethics)**
9. Function effectively as an individual, and as a member or leader in diverse teams, and in multidisciplinary settings. **(Individual and team work)**
10. Communicate effectively on complex engineering activities with the engineering community and with society at large, such as, being able to comprehend and write effective reports and design documentation, make effective presentations, and give and receive clear instructions. **(Communication)**
11. Demonstrate knowledge and understanding of the engineering and management principles and apply these to one's own work, as a member and leader in a team, to manage projects and in multidisciplinary environments. **(Project management and finance)**
12. Recognize the need for, and have the preparation and ability to engage in independent and life-long learning in the broadest context of technological change. **(Life-long learning)**

## **PROGRAM SPECIFIC OUTCOMES**

On successful completion of the Program, the graduates of B.Tech. (CE) program will be able to:

- PSO1:** Plan, draw, analyze, design, construct, evaluate, manage, maintain, retrofit and rehabilitate civil engineering systems and processes by applying suitable materials, tools and techniques.
- PSO2:** Identify minerals, rocks, structural geology problems and understand geological maps; characterize soil; choose foundations; select ground improvement techniques; and plan and design transport systems.
- PSO3:** Perform land survey; plan, design, construct, maintain and manage water resources systems; analyze water and wastewater; manage solid waste; plan, design and execute environmental systems and processes.

**SREE VIDYANIKETHANENGINEERINGCOLLEGE(AUTONOMOUS)**  
**(Affiliated to J.N.T.University Anantapur, Ananthapuramu)**

**ACADEMIC REGULATIONS (SVEC-19)**

**CHOICE BASED CREDIT SYSTEM**

**B.Tech. Regular Four Year Degree Program**

**(For the batches admitted from the academic year 2019–20)**

**and**

**B.Tech. (Lateral Entry Scheme)**

**(For the batches admitted from the academic year 2020-21)**

For pursuing four year undergraduate Degree Program B.Tech offered by SreeVidyanikethanEngineeringCollege under Autonomous status and herein after referred to as SVEC:

**1. Applicability:**

All the rules specified herein, approved by the Academic Council, shall be in force and applicable to students admitted from the academic year 2019-2020 onwards. Any reference to "College" in these rules and regulations stands for SVEC.

**2. Extent:**

All the rules and regulations, specified hereinafter shall be read as a whole for the purpose of interpretation and as and when a doubt arises, the interpretation of the Chairman, Academic Council is final. It shall be ratified by the Academic Council in the forthcoming meeting. As per the requirements of statutory bodies, Principal, Sree Vidyanikethan Engineering College shall be the Chairman, Academic Council.

**3. Admission:**

**3.1.Admission into First Year of Four Year B.Tech. Degree Program in Engineering:**

**3.1.1. Eligibility:** A candidate seeking admission into the First Year of four year B.Tech. Degree Program should have:

Passed either Intermediate Public Examination (I.P.E.) conducted by the Board of Intermediate Education, Andhra Pradesh, with Mathematics, Physics and Chemistry as optional courses (or any equivalent examination recognized by JNTUA, Ananthapuramu) for admission as per the guidelines of Andhra Pradesh State Council of Higher Education (APSCHE).

**3.1.2. Admission Procedure:** Admissions shall be made into the first year of four year B.Tech. Degree Program as per the stipulations of APSCHE, Government of Andhra Pradesh:

- (a) By the Convener, EAMCET, (for Category-A Seats).
- (b) By the Management (for Category-B Seats).
- (c) By the Management (for 15% Supernumerary Quota) for Persons of Indian Origin (PIO)/Foreign Nationals (FN)/ Children of Indian Workers in Gulf Countries/ Overseas Citizen of India (OCI)

### **3.2. Admission into the Second Year of Four year B.Tech Degree Program in Engineering (Lateral Entry).**

**3.2.1. Eligibility:** A candidate seeking admission into the Second Year of four year B.Tech. Degree Program (Lateral Entry) should have:

- (i) Passed Diploma in Engineering in the relevant branch conducted by the Board of Technical Education, Andhra Pradesh (or equivalent Diploma recognized by JNTUA, Ananthapuramu).
- (ii) Candidates qualified in ECET and admitted by the Convener, ECET. In all such cases for admission, when needed, permissions from the statutory bodies are to be obtained.

**3.2.2. Admission Procedure:** 10% of the sanctioned strength in each Program of study as lateral entry students or as stipulated by APSCHE shall be filled in by the Convener, ECET.

### **4. Programs of study offered leading to the award of B.Tech. Degree:**

Following are the four year undergraduate Degree Programs of study offered in various branches in SVEC leading to the award of B.Tech (Bachelor of Technology) Degree:

- 1) Civil Engineering
- 2) Electrical and Electronics Engineering
- 3) Mechanical Engineering
- 4) Electronics and Communication Engineering
- 5) Computer Science and Engineering
- 6) Electronics and Instrumentation Engineering
- 7) Information Technology
- 8) Computer Science and Systems Engineering

### **5. Duration of the Program:**

**5.1 Minimum Duration:** The program shall extend over a period of four years leading to the Degree of Bachelor of Technology (B.Tech) of the JNTUA, Ananthapuramu. The four academic years shall be divided into eight semesters with two semesters per year. Each semester shall normally consist of 21 weeks (Minimum of 90 working days) having - Continuous Internal Evaluation (CIE) and



Semester End Examination (SEE), Choice Based Credit System (CBCS) and Credit Based Semester System (CBSS) as suggested by UGC and Curriculum/ Course Structure as suggested by AICTE are followed. Provision is made for lateral entry admission of students into the Second Year of the program in all the branches of study and they shall be required to satisfy the conditions of admissions thereto prescribed by the JNTUA, Ananthapuramu and Government of Andhra Pradesh.

### 5.2 Maximum Duration:

The student shall complete all the passing requirements of the B.Tech degree program within a maximum duration of 8 years (6 years for lateral entry), these durations reckoned from the commencement of the semester to which the student was first admitted to the program.

### 6. Structure of the Program:

Each Program of study shall consist of:

- (i) HS (Humanities and Social Sciences) Courses
- (ii) BS (Basic Sciences) Courses
- (iii) ES (Engineering Sciences) Courses
- (iv) PC (Professional Core) Courses
- (v) PE (Professional Electives)
- (vi) OE (Open Electives) Courses
- (vii) Mandatory Courses (MC)
- (viii) Audit Courses (AC)
- (ix) Projects (PR) (Socially Relevant Projects, Internship, Project Work)

S.No	Course Category	Course Type	No. of Credits
1.	HS – Humanities and Social Sciences	Humanities, Social Sciences and Management.	11
2.	BS – Basic Sciences	Mathematics, Physics and Chemistry Courses, etc.	22
3.	ES – Engineering Sciences	Fundamental Engineering courses.	22-23
4.	PC – Professional Core	Core courses related to the Parent Discipline/ Branch of Engg.	60-61
5.	PE – Professional Electives	Elective courses related to the Parent Discipline/ Branch of Engg.	15
6.	OE – Open Electives	Electives from other technical and /or emerging subjects	15
7.	PR - Projects	Socially Relevant Projects, Internship, Project Work	14
8.	MC - Mandatory Courses	Induction Program, Environmental Science, Universal Human Values	--
9.	AC - Audit Courses	Skill Development / Value Added Courses.	--

## **Contact Periods:**

The contact periods per week are assigned depending on the complexity and volume of the course.

## **7. Credit Courses:**

All Courses are to be registered by a student in a Semester to earn Credits. Credits shall be assigned to each Course in a L: T: P: C (Lecture Hours: Tutorial Hours: Practical Hours: Credits) Structure, based on the following general pattern.

- **Theory Courses:** One Lecture Hour (L) per week in a semester: 01 Credit
- **Practical Courses:** One Practical Hour (P) Per week in a semester: 0.5 Credit
- **Tutorial:** One Tutorial Hour (T) Per week in a semester: 01 Credit
- **Mandatory Courses:** No **CREDIT** is awarded.
- **Audit Courses:** No **CREDIT** is awarded.
- **Open Elective (MOOC):** 03 Credits

Student activities like NCC, NSS, Sports, Study Tour and Guest Lecture etc. shall not carry ANY Credits.

For Socially Relevant Projects, Internship and Project Work where formal contact periods are not specified, credits are assigned based on the complexity of the work to be carried out.

The four year curriculum of any B. Tech Program of study shall have a total of **160** credits. However the curriculum for students admitted under lateral entry shall have a total of **118** credits.

## **8. Choice Based Credit System (CBCS):**

Choice Based Credit System (CBCS) is introduced in line with UGC guidelines in order to promote:

- Student centred learning
- Students to learn courses of their choice
- Interdisciplinary learning

A Student has a choice of registering for courses comprising program core, professional electives, open electives, MOOC courses, value added / Skill based courses. Besides, choice is also offered to students for registering courses to earn Minor in Engineering/Honors degree.

## **9. Course Enrollment and Registration**

- 9.1** Each student, on admission shall be assigned to a Faculty Advisor (Mentor) who shall advise and counsel the student about the details of the academic program and the choice of courses considering the student's academic background and career objectives.
- 9.2** Each student on admission shall register for all the courses prescribed in the curriculum in the student's first and second Semesters of study. The student shall enroll for the courses with the help of the student's Faculty Advisor (Mentor). The enrollment for the courses from II B.Tech I Semester to IV B.Tech I Semester shall commence 10 days prior to the last instructional day of the preceding semester for registration process. If the student wishes, the student may drop or add courses (vide clause 8) 10 days prior to commencement of the concerned semester and complete the registration process duly authorized by the Chairman, Board of Studies of concerned department.
- 9.3** If any student fails to register the courses in a semester, he shall undergo the courses as per the program structure.
- 9.4** After registering for a course, a student shall attend the classes, satisfy the attendance requirements, earn Continuous Assessment marks and appear for the Semester-end Examinations.
- 9.5** Elective courses shall be offered by a Department only if a minimum of 40 students register for that course.

## **10. OPEN ELECTIVE (MOOC)**

OPEN ELECTIVE (MOOC) is an online course aimed at unlimited participation and open access via the web.

- 10.1** A Student is offered an Open Elective (MOOC), in the IV B.Tech I-Semester, and is pursued through Massive Open Online Course (MOOC) platforms. The duration of the MOOC courses shall be for a minimum period of 08 weeks.
- 10.2** The student shall confirm registration by enrolling the course within 10 days prior to the last instructional day of the III B.Tech II-Semester along with other courses.
- 10.3** The list of courses along with MOOC service providers shall be identified by the Chairman, BOS, and Head of the Department. The identified Open Elective (MOOC) courses are to be approved by the Chairman, Academic Council.

- 10.4** The student has to submit MOOC certificate with percentage of Score earned to the Head of the Department at the end of the semester. Based on the score earned, the equivalent Grade Point and Credits will be assigned.
- 10.5** Attendance is not applicable for MOOC Course and also attendance will not be monitored.
- 10.6** If the student fails to submit the MOOC certificate at the end of the semester, his performance in MOOC will be shown as "Fail" in the Grade sheet. Then the student shall register for the supplementary examinations and submit the MOOC certificate.

**11. BREAK OF STUDY FROM A PROGRAM (Gap Year)**

- 11.1** A student is permitted to go on break of study for a maximum period of two years either as two breaks of one year each or a single break of two years.
- 11.2** In case, a student wishes to extend the gap year for one more consecutive year, he shall be permitted with the prior approval of the Principal on the recommendations of the Head of the Department prior to the beginning of the semester in which he has taken break of study.
- 11.3** The student shall apply for break of study in advance, in any case, not later than the last date of the first assessment period in a semester. The gap year concept is introduced for start-up (or) incubation of an idea, National/International Internships, and professional Volunteering. The application downloaded from the website and duly filled in by the student shall be submitted to the Principal through the Head of the department. A committee shall be appointed by the Principal in this regard. Based on the recommendations of the committee, Principal shall decide whether to permit the student to avail the gap year or not.
- 11.4** The students permitted to rejoin the program after break of study shall be governed by the Curriculum and Regulations in force at the time of rejoining.
- The students rejoining in new regulations shall apply to the Principal in the prescribed format through Head of the Department, at the beginning of the readmitted semester for registering additional/equivalent courses to comply with the curriculum in-force.
- 11.5** The two years period of break of study shall not be counted for the maximum Period of graduation (i.e the maximum period of graduation is 10 years for

Regular admitted students and 8 years for Lateral Entry admitted students availing Gap Year).

- 11.6** If a student has not reported to the college after completion of the approved period of break of study he is deemed to be detained in that semester. Such students are eligible for readmission into the semester when offered next.

**12. Examination System:**

- 12.1** All components in any Program of study shall be evaluated through internal evaluation and/or an external evaluation conducted as Semester-end examination.

Sl. No.	Course	Marks	Examination and Evaluation		Scheme of examination
1.	Theory	60	Semester-end examination for 3 hours duration (External evaluation)		The examination question paper in theory courses shall be for a maximum of 60 marks. The question paper shall be of descriptive type with 10 questions each of 12 marks, taken two from each unit. Each unit shall have internal choice and 5 questions shall be answered, one from each unit.
			10	Assignments (Internal evaluation).	One Assignment shall be given to the student for 10 marks during the semester and Assignment Marks finalized.
		40	30	Mid-term Examination of 2 hours duration (Internal evaluation).	Two mid-term examinations each for 30 marks are to be conducted. For a total of 30 marks, 80% of better one of the two and 20% of the other one are added and finalized. <b>Mid-I:</b> After first spell of instruction (I & II Units). <b>Mid-II:</b> After second spell of instruction (III, IV & V Units). The question paper shall be of descriptive type with 5 essay type questions each of 8 marks, out of which 3 are to be answered and evaluated for 24 marks. There shall also be 6 short answer questions each of 01 mark, all are to be answered and evaluated for 6 marks.
2.	Laboratory	50	Semester-end Lab Examination for 3 hours duration (External evaluation)		The examination shall be conducted by the faculty member handling the laboratory (Examiner-2) and another faculty member (Examiner-1) appointed by the Chief Controller of Examinations.

Sl. No.	Course	Marks	Examination and Evaluation		Scheme of examination
		50	30	Day-to-Day evaluation for Performance in laboratory experiments and Record. (Internal evaluation).	Two laboratory examinations, which includes Day-to-Day evaluation and Practical test, each for 50 marks are to be evaluated by the faculty members handling the laboratory. For a total of 50 marks 80% of better one of the two and 20% of the other one are added and finalized. <b>Laboratory examination-I:</b> Shall be conducted just before FIRST mid-term examinations. <b>Laboratory examination-II:</b> Shall be conducted just before SECOND mid-term examinations.
			20	Practical test (Internal evaluation).	
3.	Internship	100	Semester-end Examination		The evaluation shall be done by the Department Evaluation Committee ( <b>DEC</b> ) at the end of the semester as given in 12.2.1.
4.	Open Elective (MOOC)	100	-		The student has to submit MOOC certificate with percentage of Score earned to the Head of the Department at the end of the semester. Based on the score the equivalent Grade Point and Credits will be assigned as given in 10.4.
5.	Socially Relevant Project	100	50	Internal Evaluation	Shall be evaluated as given in 12.2.2(i)
			50	Semester-end evaluation	Viva-Voce examination shall be conducted at the end of the semester as given in 12.2.2(ii)
6.	Mandatory Courses	40	Internal Evaluation		Shall be evaluated as given in 12.2.4
7.	Audit Courses	-	-		As detailed in 12.2.5
8.	Project Work	200	100	Internal evaluation	Continuous evaluation shall be done by the Project Evaluation Committee ( <b>PEC</b> ) as given in 12.2.3.
			100	Semester-end evaluation	Project Work Viva-Voce Examination shall be conducted by a Committee at the end of the semester as given in 12.2.3.

## 12.2 Internship/Socially Relevant Project/Project Work/Mandatory Course/ Audit Course Evaluation:

### 12.2.1 Internship:

The student shall undergo **Internship** in an Industry/National Laboratories/Academic Institutions relevant to the respective branch of study. This course is to be registered during III B.Tech II-Semester and taken up during the summer vacation after completion of the III B.Tech II-Semester, for a period of FOUR weeks duration. The Industry Training/Internship shall be submitted in a Report form, and a presentation of the same shall be made before a Department Evaluation Committee (DEC) and it should be evaluated for 100 marks. The DEC

shall consist of the Head of the Department, the concerned Supervisor and a Senior Faculty Member of the Department. The DEC is constituted by the Chief Controller of Examinations on the recommendations of the Head of the Department. There shall be no internal marks for Internship. The Internship shall be evaluated at the end of the IV B.Tech I-Semester.

### **12.2.2 Socially Relevant Project:**

A project for community services shall be carried out in teams (maximum 5 students per team) to solve real life problems of society. The Students shall visit the society (Villages/Hospitals/social service organizations etc,.) to identify the problem, conduct literature survey and provide a feasible solution. Each team shall work under the supervision of a guide (faculty member).

- (i) Internal Evaluation: Two internal evaluations (First evaluation before the I-Mid-term examinations and second evaluation before the II-Mid-term examinations) shall be conducted by the guide and a faculty member nominated by the HOD. For a total of 50 marks, 80% of better one of the two and 20% of the other one are added and finalized.
- (ii) Semester-end Evaluation: A report on socially relevant project shall be submitted by the team of students to the department at the end of the semester. The Viva-Voce examination shall be conducted by the concerned guide and a senior faculty member recommended by the Head of the Department and appointed by the Chief Controller of Examinations.

### **12.2.3 Project Work:**

- (i) Internal Evaluation: The Internal Evaluation shall be made by the Project Evaluation Committee (PEC) consisting of concerned supervisor and two senior faculty members, on the basis of TWO project reviews on the topic of the project. Each review shall be conducted for a maximum of "100" marks. For a total of 100 marks, 80% of better one of the two and 20% of the other one are added and finalized. The PEC is constituted by the Principal on the recommendations of the Head of the Department.
- (ii) Semester-end Evaluation: The Semester-end Project Work Viva-Voce Examination shall be conducted by a Committee consisting of External examiner (nominated by the Chief Controller of Examinations), HOD and concerned Supervisor. The evaluation of project work shall be done at the end of the IV B.Tech II Semester.

Three copies of the dissertation certified in the prescribed format by the concerned Supervisor and HOD shall be submitted to the Department. One copy is to be submitted to the Chief Controller of Examinations. The examiner shall be nominated by the Chief Controller of the Examinations from the panel of SIX examiners submitted by the Department.

#### **12.2.4 Mandatory Courses:**

Mandatory courses carry "**ZERO**" credits. There shall be **NO Semester-end** examination. However, ATTENDANCE in Mandatory courses shall be considered while calculating aggregate attendance in a semester. The internal examination shall be conducted and evaluated similar to the THEORY courses. The student shall be declared to have passed the mandatory courses only when HE secures **40% marks in the internal examination**. If the student FAILS, a re-examination shall be conducted for FAILED candidates in the CONSEQUETIVE semester. The performance of the student shall be indicated in the grade sheets "**SATISFACTORY**" (or) "**NOT SATISFACTORY**" as given in 17.1. The student should pass all the mandatory courses, for the award of B.Tech degree.

#### **12.2.5 Audit Courses:**

Audit courses carry "ZERO" credits. There shall be **NO Internal and Semester-end examination**. However, ATTENDANCE in Audit courses shall be considered while calculating aggregate attendance in a semester. The student should study all the audit courses, and it shall be indicated in the GRADE Sheet.

### **12.3. Eligibility to appear for the Semester-End Examination (SEE):**

**12.3.1** A student shall be eligible to appear for semester-end examinations if he acquires a minimum of 75% of attendance in aggregate of all the courses in a semester.

**12.3.2** Condonation of shortage of attendance in aggregate up to 10% (65% and above and below 75%) in each semester may be granted by the College Academic Committee.

**12.3.3** Shortage of Attendance below 65% in aggregate **shall in no case be condoned**.

**12.3.4** Students whose shortage of attendance is not condoned in any semester are not eligible to take their semester-end examinations of that class and their registration shall stand cancelled.



**12.3.5** A student shall not be promoted to the next semester unless he satisfies the attendance requirements of the current semester, as applicable. The student may seek readmission for the semester when offered next. He shall not be allowed to register for the courses of the semester while he is in detention. A student detained due to shortage of attendance, shall have to repeat that semester when offered next.

**12.3.6** A stipulated fee shall be payable to the College towards Condonation of shortage of attendance.

**12.3.7** The attendance in ***Student Development Activities*** shall be considered for finalization of aggregate attendance.

**12.3.8** For the calculation of a student attendance in any semester, the total number of classes conducted shall be counted as scheduled in the class-work time table.

#### **12.4. Evaluation:**

Following procedure governs the evaluation.

**12.4.1.** Marks for components evaluated internally by the faculty shall be submitted to the Controller of Examinations one week before the commencement of the Semester-end examinations. The marks for the internal evaluation components shall be added to the external evaluation marks secured in the Semester-end examinations, to arrive at the total marks for any course in that semester.

**12.4.2.** Performance in all the courses is tabulated course-wise and shall be scrutinized by the Results Committee and moderation is applied if needed and course-wise marks are finalized. Total marks obtained in each course are converted into letter grades.

**12.4.3.** Student-wise tabulation shall be done and individual grade Sheet shall be generated and issued to the student.

#### **12.5. Recounting/Revaluation/Personal Verification/Challenging Evaluation:**

Students shall be permitted to apply for **Recounting/Revaluation/Personal Verification/Challenging Evaluation** of the Semester-end examination answer scripts within a stipulated period after payment of the prescribed fee. After completion of the process of **Recounting/Revaluation/Personal Verification/Challenging Evaluation**, the records are updated with changes if any, and the student shall be issued a revised grade sheet. If there are no changes, the student shall be intimated the same through a notice.

### **12.6. Supplementary Examination:**

In addition to the regular semester-end examinations conducted, the College may also schedule and conduct supplementary examinations for all the courses of other semesters when feasible for the benefit of students. Such of the candidates writing supplementary examinations may have to write more than one examination per day.

### **13. Academic Requirements for promotion/completion of regular B.Tech Program of study:**

The following academic requirements have to be satisfied in addition to the attendance requirements for promotion/completion of regular B.Tech Program of study.

#### **For students admitted into B.Tech. (Regular) Program:**

- 13.1** A student shall be deemed to have satisfied the minimum academic requirements for each theory course, laboratory course, socially relevant project and project work, if he secures not less than 40% of marks in the Semester-end examination and a minimum of 40% of marks in the sum total of the internal evaluation and Semester-end examination taken together. For the courses "**Internship**" and "**Open Elective (MOOC)**", he should secure not less than 40% of marks in the semester-end examination.
- 13.2** A student shall be promoted from second year to third year of Program of study only if he fulfills the academic requirement of securing 25 credits from the following examinations (Irrespective of whether or not the candidate appears for the semester-end examinations as per the normal course of study):
- a. **One** regular and **two** supplementary examinations of I B.Tech I Semester.
  - b. **One** regular and **one** supplementary examinations of I B.Tech II Semester.
  - c. **One** regular examination of II B.Tech I Semester.
- 13.3** A student shall be promoted from third year to fourth year of Program of study only if he fulfills the academic requirements of securing 42 credits from the following examinations (Irrespective of whether or not the candidate appears for the semester-end examinations as per the normal course of study):
- a. **One** regular and **four** supplementary examinations of I B.Tech I Semester.
  - b. **One** regular and **three** supplementary examinations of I B.Tech II Semester.

- c. **One** regular and **two** supplementary examinations of II B.Tech I Semester.
- d. **One** regular and **one** supplementary examinations of II B.Tech II Semester.
- e. **One** regular examination of III B.Tech I Semester.

\* In case of getting detained for want of credits by sections 13.2 and 13.3 above, the student may make up the credits through supplementary examinations.

- 13.4** A student shall register for all the 160 credits and earn all the 160 credits. Marks obtained in all the 160 credits shall be considered for the calculation of the DIVISION based on CGPA.
- 13.5** A student who fails to earn 160 credits as indicated in the course structure within eight academic years from the year of their admission shall forfeit his seat in B.Tech. Program and his admission stands cancelled.

**For Lateral Entry Students (batches admitted from the academic year 2020-2021):**

- 13.6** A student shall be deemed to have satisfied the minimum academic requirements for each theory, practical course, Socially relevant project and Project Work, if he secures not less than 40% of marks in the semester-end examination and a minimum of 40% of marks in the sum total of the internal evaluation and semester-end examination taken together. For the courses "Internship" and "Open Elective (MOOC)", he shall be declared to have passed if he secures minimum of 40% of marks in the semester-end examination.
- 13.7** A student shall be promoted from third year to fourth year only if he fulfills the academic requirements of securing 25 credits from the following examinations:
  - a. **One** regular and **Two** supplementary examinations of II B.Tech I Semester.
  - b. **One** regular and **One** supplementary examinations of II B.Tech II Semester.
  - c. **One** regular examination of III B.Tech I Semester.

Irrespective of whether or not the candidate appears for the semester-end examination as per the normal course of study and in case of getting detained for want of credits the student may make up the credits through supplementary examinations.

- 13.8** A student shall register for all 118 credits and earn all the 118 credits. Marks obtained in all the 118 credits shall be considered for the calculation of the DIVISION based on CGPA.
- 13.9** A student who fails to earn 118 credits as indicated in the course structure within six academic years from the year of their admission shall forfeit his seat in B.Tech Program and his admission stands cancelled.

#### 14. Academic Regulations for Minor Degree:

The concept of Minor degree is introduced in the curriculum of all B.Tech. programs offering a Major degree. The main objective of Minor degree in a discipline is to provide additional learning opportunities for academically motivated students and it is an optional feature of the B.Tech. Program. To earn a Minor degree in a discipline, a student has to earn 18 extra credits (By studying FIVE theory & THREE laboratory courses or SIX Theory Courses) from the core courses of the minor discipline.

- a. Students having a CGPA of 8.0 or above up to II B.Tech I-Semester without any backlogs shall be permitted to register for a Minor degree by paying the requisite fee.
- b. In the subsequent semesters, the student has to pass all the courses registered for Major and Minor Degrees in the first attempt i.e., regular examinations without any backlog to keep the Minor Degree registration active or else it shall be canceled.
- c. If a student becomes ineligible for continuing the Minor Degree, the earned credits under Minor Degree cannot be transferred to Major Degree; they will remain extra. These additional courses will be mentioned in the transcript. However, they are eligible to receive B.Tech. Degree after satisfying its requirements.
- d. The evaluation pattern of the courses shall be similar to the evaluation of regular program courses.
- e. Minimum strength required for offering **Minor Degree in a** discipline is 40 students.
- f. **A student registered for Minor degree shall pass in all subjects that constitute the requirement for the Minor** degree program. No class/division (i.e., second class, first class and distinction, etc.) shall be awarded for **Minor** degree program.
- g. The **Minor degree** shall be mentioned in the degree certificate as Bachelor of Technology in XXX with Minor in YYY. For example, Bachelor of Technology in Computer Science & Engineering with Minor in Title of the Minor Pursued. This shall also be mentioned in the transcripts, along with the list of courses taken for **Minor degree** program. However, the performance of the student in the Minor courses will not be considered for the calculation of SGPA and CGPA for the award of Major Degree.
- h. Separate course/class work and time table shall be arranged for the various Minor degree programs. Attendance regulations for these Minor discipline programs shall be as per regular courses.
- i. Students aspiring for Minor degree must register from III B.Tech I-Semester onwards and must opt for a Minor in a discipline other than the discipline he is

registered in.

- j. A Student shall register for Minor with the following combinations:

**Offering Theory and Laboratory Courses:** SEVEN credits in a semester starting from III B.Tech I-Semester to III B.Tech II-Semester (TWO theory & ONE laboratory courses) and FOUR credits in IV B.Tech I-Semester (ONE theory & ONE laboratory courses).

**Offering Theory Courses only:** SIX credits in a semester starting from III B.Tech I-Semester to IV B.Tech I-Semester (TWO theory courses).

**NOTE:** Interested meritorious students shall be permitted to register either for a Minor degree in a discipline (or) Honors Degree in a discipline only, but not both.

### **15. Academic Regulations for Honors Degree:**

The concept of Honors degree is introduced in the curriculum for all B. Tech. programs. The main objective of Honors degree is to provide additional learning opportunities for academically motivated students in the same or allied discipline and it is an optional feature of the B. Tech. program. In order to earn Honors degree in a discipline, a student has to earn **18** extra credits (By studying FIVE theory & THREE laboratory courses or SIX Theory Courses).

- a. Students having a CGPA of 8.0 and above up to II B.Tech I-Semester without any backlogs shall be permitted to register for Degree with Honors by paying the requisite fee.
- b. In the subsequent semesters, the student has to pass all the courses registered for Major and Honors Degrees in the first attempt i.e., regular examinations without any backlog to keep the Honors Degree registration active or else it shall be canceled.
- c. If a student becomes ineligible for continuing the Honors Degree, the earned credits under Honors Degree cannot be transferred to Major Degree; they will remain extra. These additional courses will be mentioned in the transcript. However, they are eligible to receive B.Tech. Degree after satisfying its requirements.
- d. The evaluation pattern of the courses shall be similar to the evaluation of regular program courses.
- e. Minimum strength required for offering **Honors in a** discipline is 10% of sanctioned intake.
- f. A student registered for Honors degree shall pass in all subjects that constitute the requirement for the Honors degree program. No class/division (i.e., second class, first class and distinction, etc.) shall be awarded for Honors degree program.

- g. The **Honors degree** shall be mentioned in the degree certificate as Bachelor of Technology Honors in XXX. Example, Bachelor of Technology (Honors) in Computer Science & Engineering. This shall also be reflected in the transcripts, along with the list of courses taken for **Honors degree** program. However, the performance of the student in the Honors courses will not be considered for the calculation of SGPA and CGPA for the award of Major Degree.
- h. Separate course/class work and time table shall be arranged for the various Honors degree programs. Attendance regulations for these Honors discipline programs shall be as per regular courses.
- i. Students aspiring for Honors degree must register from III B.Tech I-Semester onwards.
- j. A Student shall register for Honors with following combinations:

**Offering Theory and Laboratory Courses:** SEVEN credits in a semester starting from III B.Tech I-Semester to III B.Tech II-Semester (TWO theory & ONE laboratory courses) and FOUR credits in IV B.Tech I-Semester (ONE theory & ONE laboratory courses).

**Offering Theory Courses only:** SIX credits in a semester starting from III B.Tech I-Semester to IV B.Tech I-Semester (TWO theory courses).

**NOTE:** Interested meritorious students shall be permitted to register either for Minordegree in a discipline (or) Honors Degree in a discipline only, but not both.

#### **16. Transitory Regulations:**

Students who got detained for want of attendance (or) who have not fulfilled academic requirements (or) who have failed after having undergone the Program in earlier regulations (or) who have discontinued and wish to continue the Program are eligible for admission into the unfinished semester from the date of commencement of class work with the same (or) equivalent courses as and when courses are offered and they shall be in the academic regulations into which they are presently readmitted.

A regular student has to satisfy all the eligibility requirements within the maximum stipulated period of eight years and a lateral entry student within six years for the award of B.Tech Degree.

## 17. Grades, Semester Grade Point Average and Cumulative Grade Point Average:

17.1. **Grade System:** After all the components and sub-components of any course (including laboratory courses) are evaluated, the final total marks obtained shall be converted into letter grades on a "10 point scale" as described below.

### Grades Conversion and Grade points Attached

% of Marks obtained	Grade	Description of Grade	Grade Points (GP)
> = 95	O	Outstanding	10
> = 85 to < 95	S	Superior	9
> = 75 to < 85	A	Excellent	8
> = 65 to < 75	B	Very Good	7
> = 55 to < 65	C	Good	6
> = 45 to < 55	D	Fair	5
> = 40 to < 45	E	Pass	4
< 40	F	Fail	0
Not Appeared	N	Absent	0
<b>For Mandatory Courses</b>			
>=40	P	Satisfactory	-
<40	I	Not Satisfactory	-

#### Pass Marks:

A student shall be declared to have passed theory course, laboratory course, Socially relevant project and project work if he secures minimum of 40% marks in external examination, and a minimum of 40% marks in the sum total of internal evaluation and external examination taken together. For Industrial training/internship he shall be declared to have passed if he secures minimum of 40% of marks in the semester-end examination. Otherwise, he shall be awarded fail grade - 'F' in such a course irrespective of internal marks. 'F' is considered as a fail grade indicating that the student has to pass the Semester-End Examination in that course in future and obtain a grade other than 'F' and 'N' for passing the course.

*For the Mandatory Courses, if the student obtained 40% or more marks, then his performance shall be indicated as "P" (SATISFACTORY), otherwise the performance shall be indicated as "I" (NOT SATISFACTORY) in the grade sheet.*

- 17.2. Semester Grade Point Average (SGPA):** SGPA shall be calculated as given below on a "10 point scale" as an index of the student's performance:

$$SGPA = \frac{\sum(C \times GP)}{\sum C}$$

Where "C" denotes the "credits" assigned to the courses undertaken in that semester and "GP" denotes the "grade points" earned by the student in the respective courses.

**Note:** SGPA is calculated only for the candidates who appeared in the semester-end regular examinations in a particular semester:

**17.3. Cumulative Grade Point Average (CGPA):**

The CGPA shall be calculated for a candidate appeared in the Semester-end examinations for all the courses (including Regular & Supplementary) till that semester. The CGPA shall be displayed in the Grade sheet of the Regular Semester-end examinations and also in the consolidated Grade Sheet issued at the end of the program. The CGPA is computed on a 10 point scale as given below:

$$CGPA = \frac{\sum(C \times GP)}{\sum C}$$

where C denotes the credits assigned to courses undertaken up to the end of the Program and GP denotes the grade points earned by the student in the respective courses.

- 18. Grade Sheet:** A grade sheet (Marks Memorandum) shall be issued to each student on his performance in all the courses registered in that semester indicating the **SGPA and CGPA.**
- 19. Consolidated Grade Sheet:** After successful completion of the entire Program of study, a Consolidated Grade Sheet indicating performance of all academic years shall be issued as a final record. Duplicate Consolidated Grade Sheet shall also be issued, if required, after payment of requisite fee.
- 20. Award of Degree:** The Degree shall be conferred and awarded by Jawaharlal Nehru Technological University Anantapur, Ananthapuramu on the recommendations of the Chairman, Academic Council, SVEC (Autonomous).



**20.1. Eligibility:** A student shall be eligible for the award of B.Tech Degree if he fulfills all the following conditions:

- Registered and successfully completed all the components prescribed in the Program of study to which he is admitted.
- Successfully acquired the minimum required credits as specified in the curriculum corresponding to the branch of study within the stipulated time.
- Obtained CGPA greater than or equal to 4.0 (Minimum requirement for declaring as passed).
- Has NO DUES to the College, Hostel, Library etc. and to any other amenities provided by the College.
- No disciplinary action is pending against him.

**20.2. Award of Division:** Declaration of Division is based on CGPA.

#### **Awarding of Division**

<b>CGPA</b>	<b>Division</b>
$\geq 7.0$	First Class with Distinction
$\geq 6.0$ and $< 7.0$	First Class
$\geq 5.0$ and $< 6.0$	Second Class
$\geq 4.0$ and $< 5.0$	Pass Class

#### **21. Additional Academic Regulations:**

**21.1** A student may appear for any number of supplementary examinations within the stipulated time to fulfill regulatory requirements for award of the degree.

**21.2** In case of malpractice/improper conduct during the examinations, guidelines shall be followed as given in the ANNEXURE-I.

**21.3** When a student is absent for any examination (Mid-term or Semester-end) he shall be awarded zero marks in that component (course) and grading shall be done accordingly.

**21.4** When a component is cancelled as a penalty, he shall be awarded zero marks in that component.

#### **22. Withholding of Results:**

If the candidate has not paid dues to the College/University (or) if any case of indiscipline is pending against him, the result of the candidate shall be withheld and he shall not be allowed/promoted to the next higher semester.

#### **23. Re-Registration for Improvement of Internal Marks:**

Following are the conditions to avail the benefit of improvement of internal marks.

- 23.1 The candidate should have completed the 4 years of B.Tech course work and obtained examinations results from I B.Tech I Semester to IV B.Tech II semester.
- 23.2 Out of the courses the candidate has failed in the examinations due to internal evaluation marks secured being less than 40%, the candidate shall be given a chance for improvement of internal evaluation marks in the failed theory courses.
- 23.3 This provision is only for Theory courses. The candidate has to register for the chosen courses and fulfil the academic requirements (i.e. a student has to attend the classes regularly and appear for the mid-examinations and satisfy the attendance requirements to become eligible for appearing at the semester-end examinations).
- 23.4 For each course, the candidate has to pay a fee of Rs. 10,000/- and the amount is to be remitted in the form of D.D. in favor of the Principal, Sree Vidyaniketan Engineering College payable at Tirupati along with the requisition through the concerned Head of the Department.
- 23.5 In the event of availing the provision of Improvement of Internal evaluation marks, the internal evaluation marks as well as the Semester-end Examinations marks secured in the previous attempt(s) for the re-registered courses shall stand cancelled.

**24. Amendments to Regulations:**

The Academic Council of SVEC (Autonomous) reserves the right to revise, amend, or change the Regulations, Scheme of Examinations, and / or Syllabi or any other policy relevant to the needs of the society or industrial requirements etc., with the recommendations of the concerned Board(s) of Studies.

**25. General:**

The words such as "he", "him", "his" and "himself" shall be understood to include all students irrespective of gender connotation.

**Note:** Failure to read and understand the regulations is not an excuse.

**ANNEXURE-I**

**GUIDELINES FOR DISCIPLINARY ACTION FOR MALPRACTICES /  
IMPROPER CONDUCT IN EXAMINATIONS**

<b>Rule No.</b>	<b>Nature of Malpractices/Improper conduct</b>	<b>Punishment</b>
	<i>If the candidate:</i>	
1. (a)	Possesses or keeps accessible in examination hall, any paper, note book, programmable calculators, Cell phones, pager, palm computers or any other form of material concerned with or related to the course of the examination (theory or practical) in which he is appearing but has not made use of (material shall include any marks on the body of the candidate which can be used as an aid in the course of the examination)	Expulsion from the examination hall and cancellation of the performance in that course only.
(b)	Gives assistance or guidance or receives it from any other candidate orally or by any other body language methods or communicates through cell phones with any candidate or persons in or outside the exam hall in respect of any matter.	Expulsion from the examination hall and cancellation of the performance in that course only of all the candidates involved. In case of an outsider, he will be handed over to the police and a case is registered against him.
2.	Has copied in the examination hall from any paper, book, programmable calculators, palm computers or any other form of material relevant to the course of the examination (theory or practical) in which the candidate is appearing.	Expulsion from the examination hall and cancellation of the performance in that course and all other courses the candidate has already appeared including practical examinations and project work and shall not be permitted to appear for the remaining examinations of the courses of that Semester. The Hall Ticket of the candidate is to be cancelled.
3.	Impersonates any other candidate in connection with the examination.	The candidate who has impersonated shall be expelled from examination hall. The candidate is also debarred for four consecutive semesters from class work and all Semester-end examinations. The continuation of the course by the candidate is subject to the academic regulations in connection with forfeiture of seat. The performance of the original candidate who has been impersonated, shall be cancelled in all the courses of the examination (including labs and project work) already appeared and shall not be allowed to appear for examinations of the remaining courses of that semester. The candidate is also debarred for four consecutive semesters from class work and all Semester-end examinations, if his involvement is established. Otherwise, The candidate is debarred for two consecutive semesters from class work and all Semester-end examinations. The continuation of the course by the candidate is subject to the academic regulations in connection with forfeiture of seat. If the imposter is an outsider, he will be handed over to the police and a case is registered against him.
4.	Smuggles in the Answer book or additional sheet or takes out or arranges to send out the question paper during the examination	Expulsion from the examination hall and cancellation of performance in that course and all the other courses the candidate has already appeared

	or answer book or additional sheet, during or after the examination.	including practical examinations and project work and shall not be permitted for the remaining examinations of the courses of that semester. The candidate is also debarred for two consecutive semesters from class work and all Semester-end examinations. The continuation of the course by the candidate is subject to the academic regulations in connection with forfeiture of seat.
5.	Uses objectionable, abusive or offensive language in the answer paper or in letters to the examiners or writes to the examiner requesting him to award pass marks.	Cancellation of the performance in that course only.
6.	Refuses to obey the orders of the Chief Controller of Examinations/Controller of Examinations/any officer on duty or misbehaves or creates disturbance of any kind in and around the examination hall or organizes a walk out or instigates others to walk out, or threatens the Controller of Examinations or any person on duty in or outside the examination hall of any injury to his person or to any of his relations whether by words, either spoken or written or by signs or by visible representation, assaults the Controller of Examinations, or any person on duty in or outside the examination hall or any of his relations, or indulges in any other act of misconduct or mischief which result in damage to or destruction of property in the examination hall or any part of the College campus or engages in any other act which in the opinion of the officer on duty amounts to use of unfair means or misconduct or has the tendency to disrupt the orderly conduct of the examination.	In case of students of the college, they shall be expelled from examination halls and cancellation of their performance in that course and all other courses the candidate(s) has (have) already appeared and shall not be permitted to appear for the remaining examinations of the courses of that semester. If the candidate physically assaults the invigilator/Controller of the Examinations, then the candidate is also debarred and forfeits his/her seat. In case of outsiders, they will be handed over to the police and a police case is registered against them.
7.	Leaves the exam hall taking away answer script or intentionally tears of the script or any part thereof inside or outside the examination hall.	Expulsion from the examination hall and cancellation of performance in that course and all the other courses the candidate has already appeared including practical examinations and project work and shall not be permitted for the remaining examinations of the courses of that semester. The candidate is also debarred for two consecutive semesters from class work and all Semester-end examinations. The continuation of the course by the candidate is subject to the academic regulations in connection with forfeiture of seat.
8.	Possess any lethal weapon or firearm in the examination hall.	Expulsion from the examination hall and cancellation of the performance in that course and all other courses the candidate has already appeared including practical examinations and project work and shall not be permitted for the remaining examinations of the courses of that semester. The candidate is also debarred and forfeits the seat.

**Note:** Whenever the performance of a student is cancelled in any course(s) due to Malpractice, he has to register for Semester-end Examinations in that course(s) consequently and has to fulfill all the norms required for the award of Degree.

**SVEC19 CURRICULUM**  
**Course Structure for B.Tech. in Civil Engineering**  
 (Effective from the Academic year 2019-20 onwards)

<b>Mandatory Induction Program</b>	<b>03 Weeks Duration</b>
Induction program offered before commencement of the I-Semester course work	Physical Activity
	Creative Arts
	Universal Human Values
	Literary
	Proficiency Modules
	Lectures by Eminent People
	Visits to Local Areas
	Familiarization to Department/Branch and Innovations

**COURSE STRUCTURE****CIVIL ENGINEERING****I B.Tech I–Semester**

S. No.	Course Code	Course Title	Contact Periods per Week				Credits (C)	Scheme of Examination Max. Marks		
			L	T	P	Total		Int. Marks	Ext. Marks	Total Marks
1.	19BT1BS01	Differential Equations and Multivariable Calculus	3	1	-	4	4	40	60	100
2.	19BT1BS04	Engineering Chemistry	3	-	-	3	3	40	60	100
3.	19BT1HS01	Communicative English	3	-	-	3	3	40	60	100
4.	19BT10501	Programming for Problem Solving	3	1	-	4	4	40	60	100
5.	19BT1BS32	Engineering Chemistry Lab	-	-	2	2	1	50	50	100
6.	19BT1HS31	Communicative English Lab	-	-	2	2	1	50	50	100
7.	19BT10331	Computer Aided Engineering Drawing	-	1	2	3	2	50	50	100
8.	19BT10531	Programming for Problem Solving Lab	-	-	2	2	1	50	50	100
<b>Total</b>			<b>12</b>	<b>3</b>	<b>8</b>	<b>23</b>	<b>19</b>	<b>360</b>	<b>440</b>	<b>800</b>

**I B.Tech II–Semester**

S. No.	Course Code	Course Title	Contact Periods per Week				Credits (C)	Scheme of Examination Max. Marks		
			L	T	P	Total		Int. Marks	Ext. Marks	Total Marks
1.	19BT2BS01	Transformation Techniques and Linear Algebra	3	1	-	4	4	40	60	100
2.	19BT1BS02	Biology for Engineers	2	-	-	2	2	40	60	100
3.	19BT2BS02	Applied Physics	3	-	-	3	3	40	60	100
4.	19BT10201	Basic Electrical and Electronics Engineering	3	-	-	3	3	40	60	100
5.	19BT20101	Civil Engineering Materials and Concrete Technology	3	-	-	3	3	40	60	100
6.	19BT20102	Engineering Mechanics	3	1	-	4	4	40	60	100
7.	19BT2BS31	Applied Physics Lab	-	-	2	2	1	50	50	100
8.	19BT10231	Basic Electrical and Electronics Engineering Lab	-	-	2	2	1	50	50	100
9.	19BT20331	Engineering Workshop	-	-	2	2	1	50	50	100
10.	19BT20131	Engineering Geology Lab	-	-	2	2	1	50	50	100
<b>Total</b>			<b>17</b>	<b>2</b>	<b>8</b>	<b>27</b>	<b>23</b>	<b>440</b>	<b>560</b>	<b>1000</b>
11.	19BT1AC01	Spoken English	2	-	-	2	-	-	-	-

## II B.Tech I–Semester

S. No.	Course Code	Course Title	Contact Periods per Week				Credits (c)	Scheme of Examination Max. Marks		
			L	T	P	Total		Int. Marks	Ext. Marks	Total Marks
1.	19BT3BS01	Numerical Methods, Probability and Statistics	3	1	-	4	4	40	60	100
2.	19BT30101	Construction, Planning and Project Management	3	-	-	3	3	40	60	100
3.	19BT30102	Fluid Mechanics	3	-	-	3	3	40	60	100
4.	19BT30103	Mechanics of Solids	3	1	-	4	4	40	60	100
5.	19BT30104	Surveying	3	-	-	3	3	40	60	100
6.	19BT3HS31	Soft Skills Lab	-	-	2	2	1	50	50	100
7.	19BT30131	Civil Engineering Materials and Construction Technology Workshop	-	-	2	2	1	50	50	100
8.	19BT30132	Strength of Materials Lab	-	-	2	2	1	50	50	100
9.	19BT30133	Surveying Lab	-	-	2	2	1	50	50	100
<b>Total</b>			<b>15</b>	<b>2</b>	<b>8</b>	<b>25</b>	<b>21</b>	<b>400</b>	<b>500</b>	<b>900</b>
10.	19BT315AC	Design Thinking	2	-	-	2	-	-	-	-

## II B.Tech II–Semester

S. No.	Course Code	Course Title	Contact Periods per Week				Credits (C)	Scheme of Examination Max. Marks		
			L	T	P	Total		Int. Marks	Ext. Marks	Total Marks
1.	19BT40101	Engineering Hydrology	3	-	-	3	3	40	60	100
2.	19BT40102	Environmental Engineering	3	-	-	3	3	40	60	100
3.	19BT40103	Hydraulic Engineering	3	-	-	3	3	40	60	100
4.	19BT40104	Soil Mechanics	3	-	-	3	3	40	60	100
5.	19BT40105	Structural Analysis	3	1	-	4	4	40	60	100
6.	<b>Open Elective-2</b>		3	-	-	3	3	40	60	100
7.	19BT40131	Environmental Engineering Lab	-	-	2	2	1	50	50	100
8.	19BT40132	Fluid Mechanics and Hydraulic Machinery Lab	-	-	2	2	1	50	50	100
9.	19BT40133	Geotechnical Engineering Lab	-	-	2	2	1	50	50	100
<b>Total</b>			<b>18</b>	<b>1</b>	<b>6</b>	<b>25</b>	<b>22</b>	<b>390</b>	<b>510</b>	<b>900</b>
10.	19BT3MC01	Environmental Science	2	-	-	2	-	40	-	40

### III B.Tech I–Semester

S. No.	Course Code	Course Title	Contact Periods per Week				Credits (C)	Scheme of Examination Max. Marks		
			L	T	P	Total		Int. Marks	Ext. Marks	Total Marks
1.	19BT50101	Irrigation Engineering and Hydraulic Structures	3	-	-	3	3	40	60	100
2.	19BT50102	Foundation Engineering	3	-	-	3	3	40	60	100
3.	19BT50103	Reinforced Cement Concrete Structures	3	-	-	3	3	40	60	100
4.	19BT50104	Transportation Engineering	3	-	-	3	3	40	60	100
5.	<b>Open Elective-1</b>		3	-	-	3	3	40	60	100
6.	<b>Interdisciplinary Elective- 1</b>		3	-	-	3	3	40	60	100
	19BT50443	Principles of Image Processing								
	19BT50205	Energy Audit, Conservation and Management								
	19BT70303	Computational Fluid Dynamics								
	19BT50105	Construction Equipment and Automation								
	19BT50106	Pipeline Engineering								
7.	19BT50131	Computer Aided Building Planning and Drawing	-	-	2	2	1	50	50	100
8.	19BT50132	Transportation Engineering Lab	-	-	2	2	1	50	50	100
9.	19BT50133	Socially Relevant Project-1	-	-	-	-	1	50	50	100
<b>Total</b>			<b>18</b>	<b>-</b>	<b>4</b>	<b>22</b>	<b>21</b>	<b>390</b>	<b>510</b>	<b>900</b>
10.	19BT503AC	Foundations of Entrepreneurship	2	-	-	2	-	-	-	-



### III B.Tech II–Semester

S. No.	Course Code	Course Title	Contact Periods per Week				Credits (C)	Scheme of Examination Max. Marks		
			L	T	P	Total		Int. Marks	Ext. Marks	Total Marks
1.	19BT6HS02	Organizational Behaviour	3	-	-	3	3	40	60	100
2.	19BT60101	Steel Structures	3	-	-	3	3	40	60	100
3.	<b>Professional Elective–1</b>									
	19BT60102	Advanced Structural Analysis								
	19BT60103	Advanced Surveying								
	19BT60104	Air and Noise Pollution and Control								
	19BT60105	Architecture and Town Planning	3	-	-	3	3	40	60	100
	19BT60106	Ground Improvement Techniques								
	19BT60107	Urban Stormwater Management								
	19BT60108	Railway Engineering								
4.	<b>Professional Elective–2</b>									
	19BT60109	Advanced Reinforced Cement Concrete Structures								
	19BT60110	Geoenvironmental Engineering								
	19BT60111	Global Positioning System (GPS)								
	19BT60112	Groundwater Development and Management	3	-	-	3	3	40	60	100
	19BT60113	Rehabilitation and Retrofitting of Structures								
	19BT60114	Solid and Hazardous Waste Management								
	19BT60115	Transportation Planning and Management								
5.	<b>Professional Elective–3</b>									
	19BT60116	Earthquake Resistant Design of Structures								
	19BT60117	Highway Construction and Maintenance								
	19BT60118	Industrial Wastewater Treatment								
	19BT60119	Infrastructure Development and Management	3	-	-	3	3	40	60	100
	19BT60120	Land Survey and Real Estate Development								
	19BT60121	Soil Dynamics and Machine Foundations								
	19BT60122	Sustainable Water Resources Development								
	<b>Interdisciplinary Elective–2</b>									
	19BT60314	Optimization Techniques								
6.	19BT60342	Thermodynamics and Heat Transfer	3	-	-	3	3	40	60	100
	19BT60123	Fire Engineering								
	19BT60124	Intelligent Transportation Systems								

	19BT60125	Smart Materials and Structures								
7.	19BT61531	Internet of Things Lab	-	1	2	3	2	50	50	100
8.	19BT60131	Civil Engineering Software Lab	-	-	2	2	1	50	50	100
9.	19BT60132	Socially Relevant Project-2	-	-	-	-	1	50	50	100
<b>Total</b>			<b>18</b>	<b>1</b>	<b>4</b>	<b>23</b>	<b>22</b>	<b>390</b>	<b>510</b>	<b>900</b>
10.	19BT5MC01	Universal Human Values	2	-	-	2	-	40	-	40

**IV B.Tech I–Semester**

S. No.	Course Code	Course Title	Contact Periods per Week				Credits (C)	Scheme of Examination Max. Marks		
			L	T	P	Total		Int. Marks	Ext. Marks	Total Marks
1.	19BT6HS01	Principles of Business Economics and Accountancy	3	-	-	3	3	40	60	100
2.	19BT70101	Estimation and Quantity Surveying	3	-	-	3	3	40	60	100
3.	19BT70102	Geospatial Technologies	3	-	-	3	3	40	60	100
4.	<b>Professional Elective–4</b>									
	19BT70103	Advanced Foundation Engineering	3	-	-	3	3	40	60	100
	19BT70104	Advanced Steel Structures								
	19BT70105	Environmental Hydraulics								
	19BT70106	Pavement Analysis and Design								
	19BT70107	Prestressed Concrete								
	19BT70108	River Engineering and River Basin Management								
	19BT70109	Structural Health Monitoring								
5.	<b>Professional Elective–5</b>									
	19BT70110	Analysis and Design of Composite Structures	3	-	-	3	3	40	60	100
	19BT70111	Bridge Engineering								
	19BT70112	Civil Infrastructure for Smart City Development								
	19BT70113	Environmental Impact Assessment and Management								
	19BT70114	Geotechnics for Underground Structures								
	19BT70115	Traffic Engineering and Management								
	19BT70116	Water Resources Systems Planning and Management								
6.	19BT7MOOC	MOOC	-	-	-	-	3	-	100	100
7.	19BT70131	Remote Sensing and Geographical Information Systems Lab	-	-	2	2	1	50	50	100
8.	19BT70132	Computer Aided Design and Detailing Lab	-	-	2	2	1	50	50	100
9.	19BT70133	Internship	-	-	-	-	2	--	100	100
<b>Total</b>			<b>15</b>	<b>-</b>	<b>4</b>	<b>19</b>	<b>22</b>	<b>300</b>	<b>600</b>	<b>900</b>
10.	19BT701AC	Spread Sheet Applications in Civil Engineering	-	-	2	2	-	-	-	-

### IV B.Tech. II–Semester

S. No.	Course Code	Course Title	Contact Periods per Week				Credits (C)	Scheme of Examination Max. Marks		
			L	T	P	Total		Int. Marks	Ext. Marks	Total Marks
1.	19BT80131	Project Work	-	-	-	-	10	100	100	200
<b>Total</b>			-	-	-	-	<b>10</b>	<b>100</b>	<b>100</b>	<b>200</b>

### LIST OF COURSES FOR OPEN ELECTIVE–1 and OPEN ELECTIVE-2

Course Code	Open Elective -1	Course Code	Open Elective -2
19BT4BS01	Material Science	19BT4HS01	Banking and Insurance
19BT4HS02	Business Communication and Career Skills	19BT4HS03	Cost Accounting and Financial Management
19BT4HS04	Entrepreneurship for Micro, Small and Medium Enterprises	19BT4HS05	Gender and Environment
19BT4HS06	German Language	19BT4HS07	Indian Economy
19BT4HS08	Indian History	19BT4HS09	Life Skills
19BT4HS10	Personality Development	19BT4HS11	Professional Ethics
19BT4HS12	Women Empowerment	19BT4HS13	Indian Tradition and Culture
19BT4HS14	Constitution of India	19BT40106	Disaster Mitigation and Management
19BT40205	Reliability and Safety Engineering	19BT40107	Sustainable Engineering
19BT50107	Environmental Pollution and Control	19BT40108	Contract Laws and Regulations
19BT50108	Planning for Sustainable Development	19BT40306	Global Strategy and Technology
19BT50109	Rural Technology	19BT40307	Management Science
19BT50505	Ethical Hacking	19BT40504	Cyber Laws and Security
19BT51207	AI in Healthcare	19BT50208	Intellectual Property Rights
19BT51506	Bioinformatics	19BT50409	Green Technologies

## **HONORS DEGREE and MINOR DEGREE**

In addition to the Major Degree, Students have an opportunity to pursue either Minor Degree or Honors Degree as per the eligibility criteria mentioned in Academic Regulations Point No.: 14 & 15.

**Honors Degree:** Honors degree is awarded to the students who has undergone additional learning for 18 credits in the same discipline.

### **HONORS DEGREE IN CIVIL ENGINEERING**

Year & Semester	Course Code	Course Title	Contact Periods per week				C	Scheme of Examination Max. Marks		
			L	T	P	Total		Int. Marks	Ext. Marks	Total Marks
III B.Tech. I-Sem (2 Theory)	19BH50101	Sustainable Engineering	3	-	-	3	3	40	60	100
	19BH50102	Ecology and Environmental Impact	3	-	-	3	3	40	60	100
	19BH50103	Waste to Energy	3	-	-	3	3	40	60	100
III B.Tech. II-Sem (2 Theory)	19BH60101	Environmental Sustainability	3	-	-	3	3	40	60	100
	19BH60102	Sustainable Energy Systems	3	-	-	3	3	40	60	100
	19BH60103	Sustainability in The Built Environment	3	-	-	3	3	40	60	100
IV B.Tech. I-Sem (2 Theory)	19BH70101	Environmental Economics	3	-	-	3	3	40	60	100
	19BH70102	Sustainable Cities	3	-	-	3	3	40	60	100
	19BH70103	Sustainable Design of Technology Systems	3	-	-	3	3	40	60	100

**Minor Degree:** Minor degree is awarded to the students who has undergone additional learning for 18 credits in any discipline other than parent discipline.

### **MINOR DEGREES OFFERED UNDER SVEC-19 REGULATIONS**

Offering Department	Title of the Minor	Students of Eligible Branches
CSE	Artificial Intelligence and Machine Learning	All branches except CSE, IT and CSSE
IT	Internet of Things	All branches except IT
CSSE	Cyber Security	All branches except CSE, IT and CSSE
ECE	VLSI and Embedded Systems	All branches except ECE
EEE	Power Systems and Drives	All branches except EEE
EIE	Instrumentation and Control Engineering	All branches except EIE
ME	Robotics	All branches except ME
CE	Sustainable Engineering	All branches except CE

## I B. Tech. - I Semester

### (19BT1BS01) DIFFERENTIAL EQUATIONS AND MULTIVARIABLE CALCULUS

(Common to CE, ME, EEE, ECE, EIE, CSE, CSSE and IT)

Int. Marks	Ext. Marks	Total Marks	L	T	P	C
40	60	100	3	1	-	4

#### PRE-REQUISITES: -

**COURSE DESCRIPTION:** Ordinary Differential Equations; Partial Differential Equations; Multivariable Calculus (Differentiation); Multivariable Calculus (Integration); Multivariable Calculus (Vector Calculus).

**COURSE OUTCOMES:** After successful completion of the course, students will be able to:

- CO1: Formulate and solve differential equations by applying knowledge of calculus for engineering problems.
- CO2: Demonstrate knowledge in multivariable calculus for evaluating multiple integrals through techniques of integration.
- CO3: Identify scalar and vector valued functions and evaluate vector integrals through knowledge of vector integral theorems and techniques.

#### DETAILED SYLLABUS:

##### UNIT-I: ORDINARY DIFFERENTIAL EQUATIONS (09 Periods)

Second and higher order linear differential equations with constant coefficients: Non-Homogeneous equations with R.H.S terms of the type  $e^{ax}$ ,  $\sin ax$ ,  $\cos ax$ , polynomials in  $x$ ,  $e^{ax}V(x)$  and  $xV(x)$ ; method of variation of parameters; Equations reducible to linear differential equations with constant coefficients: Cauchy's and Legendre's linear equations; Applications to L-C-R Circuit problems.

##### UNIT-II: PARTIAL DIFFERENTIAL EQUATIONS (09 Periods)

Formation of PDE, solutions of first order linear and non-linear PDEs, solution to homogenous and non-homogenous linear partial differential equations of second and higher order by complimentary function and particular integral method, method of separation of variables in Cartesian coordinates.

##### UNIT-III: MULTIVARIABLE CALCULUS (DIFFERENTIATION) (09 Periods)

Partial derivatives, Chain rule, Total derivative, Jacobian, Maxima and Minima of functions of two variables, Lagrange's method of undetermined multipliers.

##### UNIT-IV: MULTIVARIABLE CALCULUS (INTEGRATION) (09 Periods)

Evaluation of Double integrals (Cartesian and polar coordinates), Change of order of integration (Cartesian form only); Evaluation of Triple integrals; Change of variables: double integration from Cartesian to polar coordinates, Triple integration from Cartesian to spherical and cylindrical polar coordinates; Areas enclosed by plane curves.

**UNIT-V: MULTIVARIABLE CALCULUS (VECTOR CALCULUS) (09 Periods)**

**Vector Differentiation:** Scalar and Vector fields: Gradient of a scalar field, directional derivative, divergence of a vector field, solenoidal vector, curl of a vector field, irrotational vector, Laplacian operator. **Vector Integration:** Line integral-circulation-work done, Surface integral-flux and Volume integral; Vector integral theorems: Theorems of Green, Gauss and Stokes (without proofs).

**Total Periods: 45**

**TEXT BOOKS:**

1. T. K. V. Iyengar, B. Krishna Gandhi, S. Ranganatham and M. V. S. S. N. Prasad, *Engineering Mathematics, vol-1*, S. Chand and Company, 13<sup>th</sup> edition, 2014.
2. B. S. Grewal, *Higher Engineering Mathematics*, Khanna publishers, 44<sup>th</sup> edition, 2017.

**REFERENCE BOOKS:**

1. Dennis G. Zill and Warren S. Wright, *Advanced Engineering Mathematics*, Jones and Bartlett, 6<sup>th</sup> edition, 2011.
2. R. K. Jain and S. R. K. Iyengar, *Advanced Engineering Mathematics*, Alpha Science International Ltd., 6<sup>th</sup> edition, 2017.

## I B. Tech. - I Semester

### (19BT1BS04) ENGINEERING CHEMISTRY

(Common to CE, ME, CSE, CSSE and IT)

Int. Marks	Ext. Marks	Total Marks	L	T	P	C
40	60	100	3	-	-	3

#### PRE-REQUISITES: -

**COURSE DESCRIPTION:** Atomic Structure and Bonding Theories; Water Treatment; Electrochemistry and Applications; Corrosion; Instrumental Methods and Applications; Fuel chemistry and Lubricants.

**COURSE OUTCOMES:** After successful completion of the course, students will be able to:

- CO1. Apply the basic knowledge of quantum mechanical approach to atomic structure and bonding theories to identify shapes of different orbitals and molecules.
- CO2. Analyze and solve problems associated with hardness of water, boiler troubles and address the societal, health and safety issues related to quality of water.
- CO3. Apply the basic knowledge of corrosion phenomenon to identify solutions for control of corrosion and demonstrate competency in the basic concepts of electrochemical cells.
- CO4. Demonstrate the basic knowledge of instrumental methods and their applications in the structural analysis of materials.
- CO5. Apply the basic knowledge of fuel chemistry and lubricants to identify the quality of fuels and lubricants.

#### DETAILED SYLLABUS:

##### UNIT-I: ATOMIC STRUCTURE AND BONDING THEORIES (09 Periods)

Quantum-mechanical model of atom, Schrodinger wave equation, significance of  $\Psi$  and  $\Psi^2$ , applications to particle in a box and hydrogen atom; Molecular orbital theory – bonding in homo and hetero nuclear diatomic molecules – energy level diagrams of  $N_2$ ,  $O_2$ ,  $NO$  and  $CO$ ;  $\pi$ -molecular orbitals of butadiene and benzene; VSEPR theory and molecular shapes.

##### UNIT-II: WATER TREATMENT (09 Periods)

Introduction, types of water, Impurities in water and their consequences. Hardness of water, units of hardness, disadvantages of hardness, measurement of hardness by EDTA method, numerical problems on measurement of hardness of water, boiler troubles-priming & foaming, scales & sludge, caustic embrittlement, boiler corrosion, softening of water– Ion exchange process, zeolite process, desalination of brackish water by reverse osmosis, Drinking water treatment- Ozonisation & chlorination, specifications of potable water as per WHO and BIS standards. Fluoride in ground water: Effects on human health, defluoridation method – Nalgonda method; merits and demerits of various defluoridation methods.

##### UNIT-III: ELECTROCHEMISTRY AND APPLICATIONS (10 Periods)

Electrode potential, Nernst equation, reference electrodes (Calomel electrode and glass electrode), electrochemical cell, cell potential calculations. Primary cells – dry cell, alkali



metal sulphide batteries, Secondary cells – lead acid, lithium ion batteries, Fuel cells - Hydrogen-oxygen fuel cell, Methanol-oxygen fuel cell, Solid-oxide fuel cell.

**Corrosion:** Introduction, Definition, types of corrosion- wet (galvanic corrosion, concentration cell corrosion) and dry corrosion, Factors influencing corrosion, control of corrosion- sacrificial anodic protection, Impressed current cathodic protection, electroplating method (Nickel).

#### **UNIT-IV: INSTRUMENTAL METHODS AND APPLICATIONS (09 Periods)**

Introduction to spectroscopy–types of energy present in molecules, types of spectra, UV-Vis spectroscopy – principle, types of electronic transitions, chromophore, auxochrome, Bathochromic shift, Hypsochromic shift, Instrumentation of UV-Vis spectrophotometer, applications; Infrared spectroscopy – principle, types of vibrational modes, group frequencies, Instrumentation of IR spectrophotometer, applications. principle and applications of physicochemical methods (SEM, TEM, X-ray diffraction).

#### **Unit-V: FUEL CHEMISTRY AND LUBRICANTS (08 Periods)**

**Fuel chemistry:** Types of fuels, calorific value, numerical problems based on calorific value; Liquid fuels, cracking of oils (Thermal and Fixed-bed catalytic cracking), knocking and anti-knock agents, Octane and Cetane values, Synthetic petrol: Fischer-Tropsch method and Bergius process.

**Lubricants:** Definition, functions of lubricants, mechanism of lubrication, classification of lubricants, properties of lubricants – viscosity and viscosity index , flash and fire points, cloud and pour points, Aniline points, neutralization number and mechanical strength.

**Total Periods: 45**

#### **TEXT BOOKS:**

1. P. C. Jain & Monika Jain, *Engineering Chemistry*, Dhanpat Rai Publishing Company (P) Ltd, New Delhi, 16<sup>th</sup> edition, 2013.
2. K. N. Jayaveera, G. V. Subba Reddy and C. Ramachandriah, *Engineering Chemistry*, Mc.Graw Hill Publishers, New Delhi.

#### **REFERENCE BOOKS:**

1. J. D. Lee, *Concise Inorganic Chemistry*, Oxford University Press, 5<sup>th</sup> edition 2010.
2. Skoog and West, *Principles of Instrumental Analysis*, Thomson, 6<sup>th</sup> edition, 2007.
3. Peter Atkins, Julio de Paula and James Keelar, *Atkins' Physical Chemistry*, Oxford University Press, 10<sup>th</sup> edition, 2010.

## I B. Tech – I Semester

### (19BT1HS01) COMMUNICATIVE ENGLISH

(Common to CE, ME, CSE, CSSE and IT)

Int. Marks	Ext. Marks	Total Marks	L	T	P	C
40	60	100	3	-	-	3

#### PRE-REQUISITES: -

**COURSE DESCRIPTION:** Introduction to communication; Active listening; Effective speaking; Reading; Technical writing.

**COURSE OUTCOMES:** After successful completion of the course, students will be able to:

CO1: Demonstrate knowledge of English language, examining and applying the aspects of Process of communication, Paralinguistic features, Skimming, Scanning, and Elements of style in writing.

CO2: Analyze the modes and techniques of listening, speaking, reading, writing and apply appropriately to communicate effectively with the engineering community and society.

CO3: Apply reading and writing techniques in preparing documents by examining SQ3R Technique, Writer's Block, and Précis Writing.

CO4: Communicate effectively applying appropriate speaking techniques by examining and applying the communication styles in Conferences, Symposia, Seminars and Persuasive Speaking.

#### DETAILED SYLLABUS:

##### UNIT-I: INTRODUCTION TO COMMUNICATION (09 Periods)

Introduction – Language as a Tool of Communication – Communicative Skills (Listening, Speaking, Reading and Writing) – Effective Communication – Modes of Communication– Barriers to Communication (classification) - Case study

##### UNIT-II: ACTIVE LISTENING (09 Periods)

Introduction – Traits of a Good Listener – Listening Modes – Types of Listening – Barriers to Effective Listening – Listening for General Content and Specific Information - Case study

##### UNIT-III: EFFECTIVE SPEAKING (09 Periods)

Introduction – Achieving Confidence, Clarity and Fluency – Paralinguistic Features – Barriers to Speaking – Types of Speaking – Conferences; significance, planning and preparation and procedure – Symposia and Seminars - Persuasive Speaking - Case study

##### UNIT-IV: READING (09 Periods)

Introduction – Reading and Interpretation – Intensive and Extensive Reading – Critical Reading --Techniques for Good Comprehension- SQ3R Reading Technique –Study Skills - Case study

**UNIT-V: TECHNICAL WRITING****(09 Periods)**

Introduction – Language – Elements of Style – Techniques for Good Technical Writing – Paragraphs Construction – Essays: types, Steps to Essay Writing and Checklist – Précis Writing - Case study

**Total Periods: 45****TEXT BOOKS:**

1. Meenakshi Raman & Sangeetha, Sharma, *Technical Communication*, Oxford University Press, New Delhi, 2012.
2. Ashraf Rizvi, *Effective Technical Communication*, McGraw-Hill Education (India) Pvt. Ltd., New Delhi, 2018.

**REFERENCE BOOKS:**

1. Sanjay Kumar & Pushp Lata, *Communication Skills*, Oxford University Press, New Delhi, 2013.
2. Rajendra Pal and J. S. Korlahalli, *Essentials of Business Communication*, Sultan Chand and Son, New Delhi, 2010.

**ADDITIONAL LEARNING RESOURCES:**

1. <https://www.skillsyouneed.com/ips/active-listening.html>: A useful summary of what active listening skills are.
2. [https://en.wikipedia.org/wiki/Active\\_listening](https://en.wikipedia.org/wiki/Active_listening): Wikipedia entry about active listening.
3. <https://www.forbes.com/sites/womensmedia/2012/11/09/10-steps-to-effective-listening/#4b27a2503891>: Ten steps to Active Listening (by Forbes magazine).
4. <https://goo.gl/t1Uqrt>: 20 tips for organizing a conference.
5. <https://goo.gl/kPMr9u>: 10 important issues for speakers at a conference.
6. <https://goo.gl/C5bDvv>: Wikihow guide to organizing a conference.

## I B. Tech. – I Semester

### (19BT10501) PROGRAMMING FOR PROBLEM SOLVING

(Common to CE, ME, CSE, CSSE and IT)

Int. Marks	Ext. Marks	Total Marks	L	T	P	C
40	60	100	3	1	-	4

**PRE-REQUISITES:** A Course on Basic Mathematics

**COURSE DESCRIPTION:** Introduction to problem solving approach, Introduction to Python programming, control structures, sequences, sets, Dictionaries, Implementation of Data structures using Python, Modular programming, file handling, Data representation and Visualization.

**COURSE OUTCOMES:** After successful completion of the course, students will be able to:

CO1. Demonstrate knowledge on Python constructs to solve basic problems.

CO2. Develop and use Python modules to provide solutions to problems.

#### **DETAILED SYLLABUS:**

#### **UNIT-I: INTRODUCTION TO PROBLEM SOLVING AND PYTHON PROGRAMMING**

**(10 Periods)**

**Problem Solving Aspect:** top-down design, implementation of algorithms, building blocks of flow charts, program verification and efficiency of algorithms.

**Python Programming:** tokens, literals, identifiers, keywords, special symbols and operators; fundamental data types, expressions, type conversions, handling Input and output in Python.

#### **UNIT-II: CONTROL STRUCTURES**

**(08 Periods)**

**Selection Statements:** if statement, if-else statement, if-elif-else statement, nested-if statement.

**Iterative Statements:** while loop, for loop, break statement, continue statement, pass and else statements used with loops.

#### **UNIT-III: SEQUENCES, SETS, DICTIONARIES AND DATA STRUCTURES**

**(09 Periods)**

**Sequences: Lists and operations** - creating, inserting elements, updating elements, deleting elements, searching and sorting, list comprehensions, nested lists; **tuples** - creating, searching and sorting, nested tuples; **strings** - Initializing a string and string operations, string handling methods, string formatting; **sets** - set creation and operations; **dictionaries** - operations on dictionaries, dictionary methods, sorting elements using lambdas.

**Data structures: Stacks** - push, pop, peek and display operations on stack, applications of stack; **Queues** - enqueue, dequeue and display operations on queue, applications of queues.

**UNIT-IV: MODULAR PROGRAMMING AND FILE HANDLING (10 Periods)**

**Modular Programming:** need for functions, function definition, function call, variable scope and lifetime, return statement, positional arguments, keyword arguments, default arguments and variable-length arguments, recursive functions; Modules - math, NumPy, date and time.

**File Handling:** types of files, opening and closing files, reading and writing data.

**UNIT-V: DATA REPRESENTATION AND VISUALIZATION (08 Periods)**

Pandas: creating data frame, reading data from CSV files, indexing and selecting data, dealing with rows and columns; Visualization - bar plots, histogram, Scatter Plot.

**Total Periods: 45**

**TEXT BOOKS:**

1. R. Nageswara Rao, *Core Python Programming*, 2<sup>nd</sup> edition, Dreamtech Press, 2018.
2. R. G. Dromey, *How to solve it by Computer*, Pearson, 2006.

**REFERENCE BOOKS:**

1. Reema Thareja, *Python Programming using Problem Solving Approach*, 1<sup>st</sup> edition, Oxford University Press, 2017.
2. Charles Dierbach, *Introduction to Computer Science using Python: A Computational Problem-Solving Focus*, Wiley India, 2016.

## I B. Tech. - I Semester

### (19BT1BS32) ENGINEERING CHEMISTRY LAB

(Common to CE, ME, CSE, CSSE and IT)

Int. Marks	Ext. Marks	Total Marks	L	T	P	C
50	50	100	-	-	2	1

#### PRE-REQUISITES: -

**COURSE DESCRIPTION:** Estimation of hardness, alkalinity, dissolved oxygen of water samples, Iron, Strength of an acid in Pb-acid battery and residual chlorine in drinking water by volumetric methods; Measurement of viscosity of lubricants; Instrumental methods like conductivity meter, potentiometer, P<sup>H</sup> meter and colorimeter; Characterization of simple organic compounds by UV-Vis and IR spectroscopy.

**COURSE OUTCOMES:** After successful completion of the course, students will be able to:

- CO1. Apply analytical skills for the quantitative estimation of materials through volumetric methods of analysis and address the societal, health issues related to quality of water.
- CO2. Develop analytical skills for the quantitative estimation of materials through instrumental methods of analysis.
- CO3. Work independently and in teams to solve problems with effective communication.

A minimum of any **Ten** exercises are to be conducted among the following:

#### List of Practical Exercises:

1. Estimation of Hardness of water by EDTA method
2. Determination of alkalinity of Water sample
3. Estimation of Dissolved Oxygen in water by Winkler's method.
4. Estimation Fe (II) by Dichrometry
5. Conductometric titration of strong acid Vs strong base
6. Estimation of Ferrous ion by Potentiometry
7. Determination of strength of acid by P<sup>H</sup> metric method
8. Determination of Strength of an acid in Pb-Acid battery
9. Determination of Viscosity by Ostwald's viscometer
10. Determination of percentage of Iron in Cement sample by colorimetry
11. Estimation of residual chlorine in drinking water.
12. Identification of simple organic compounds by UV-Vis and IR spectroscopy

#### TEXT BOOKS:

1. K. Mukkanti, *Practical Engineering Chemistry*, BS Publications, 2013.
2. K. N. Jayaveera, K. B. Chandra Sekhar, *Chemistry laboratory manual*, S. M. Enterprises Limited, 2013.

## I B. Tech. - I Semester

### (19BT1HS31) COMMUNICATIVE ENGLISH LAB

(Common to CE, ME, CSE, CSSE and IT)

Int. Marks	Ext. Marks	Total Marks	L	T	P	C
50	50	100	-	-	2	1

#### PRE-REQUISITES: -

**COURSE DESCRIPTION:** Phonetics; Vocabulary Building; Grammar; Just a Minute; Elocution/Impromptu; Giving Directions; Role Plays; Public Speaking; Describing Objects; Reading Comprehension; Listening Comprehension; Information Transfer; Letter Writing

**COURSE OUTCOMES:** After successful completion of the course, students will be able to:

- CO1 Demonstrate knowledge of Phonetics by examining and applying sounds of English in Phonetic Transcription.
- CO2 Analyze sentence structures by applying and demonstrating the skills of Vocabulary and Grammar.
- CO3 Apply appropriate listening and reading skills by analyzing the context and demonstrate in Listening Comprehension and Reading Comprehension.
- CO4 Function effectively as an individual and as a member in diverse teams examining and applying speaking skills in Just A Minute and Role Play.
- CO5 Communicate effectively applying appropriate writing and speaking techniques by examining and demonstrating knowledge through Describing Objects, Information Transfer and Letter Writing.

**\*First ten exercises are mandatory among the following:**

#### List of Exercises:

##### 1. Just a Minute, Elocution/Impromptu

*Steps to be followed – Useful tips – Dos & Don'ts – Preparation – Examples*

##### 2. Phonetics

*Sounds of English – Consonants – Vowels – Speech Organs – Phonetic Transcription – Word Accent – Basics of Intonation*

##### 3. Vocabulary Building

*Prefixes & Suffixes – Synonyms & Antonyms – Phrasal verbs – Idioms – One word substitutes – Words often confused*

##### 4. Grammar

*Tenses – Nouns – Word order and error correction*

##### 5. Giving Directions

*Useful phrases – Sample conversations – Exercises*

##### 6. Role Plays

*Useful tips – Dos & Don'ts – Exercises – Role Plays for practice*

##### 7. Public Speaking

*Stage presence – Voice control – Body Language – Rehearsals – Audience – Delivery – Dos & Don'ts – Project Submission*

##### 8. Letter Writing

*Introduction – Objective – Formats – Types – Exercises*

##### 9. Describing Objects

*Jargon – Useful Phrases – Do's & Don'ts – Exercises*

##### 10. Listening Comprehension

*Introduction – Types of listening – Practice – Benefits of listening – Exercises*

### **11. Information Transfer**

*Tables – Pie Charts – Venn Diagrams – Graphs – Flow Charts – Steps to be followed – Exercises*

### **12. Reading Comprehension**

*Introduction – Types of reading – Inferring – Critical analysis – Exercises*

#### **TEXT BOOK:**

1. Communicative English Lab Manual (SVEC-19)

#### **REFERENCE BOOKS:**

1. D. Sudha Rani, *A Manual for English Language Laboratories*, Pearson, Noida, 2010.
2. Nira Kumar, *English Language Laboratories*, PHI Learning Pvt. Ltd., New Delhi, 2011.

#### **SUGGESTED SOFTWARE:**

1. SoftX
2. Speech Solutions
3. English Pronunciation Dictionary by Daniel Jones
4. Learning to Speak English 8.1, The Learning Company – 4 CDs.
5. Mastering English: Grammar, Punctuation and Composition.
6. English in Mind, Herbert Puchta and Jeff Stranks with Meredith Levy, Cambridge.
7. Dorling Kindersley Series of Grammar.
8. Language in Use 1, 2 & 3
9. Cambridge Advanced Learner's Dictionary - 3rd Edition
10. Centronix – Phonetics
11. Let's Talk English, Regional Institute of English South India.

#### **ADDITIONAL LEARNING RESOURCES:**

1. <https://goo.gl/IjE45p>: Amazon India site – with thousands of different product descriptions
2. <https://goo.gl/3ozeO6>: 15 ways to calm your nerves before giving a presentation.
3. <https://goo.gl/p20ttk>: useful site for more language about introducing yourself.



## I B. Tech. – I Semester

### (19BT10331) **COMPUTER AIDED ENGINEERING DRAWING**

(Common to CE, ME, CSE, CSSE and IT)

Int. Marks	Ext. Marks	Total Marks	L	T	P	C
50	50	100	-	1	2	2

#### **PRE-REQUISITES: -**

**COURSE DESCRIPTION:** Engineering drawing conventions; Importance of engineering drawing; fundamental concepts of sketching; computer aided drafting and different types of projections of geometric entities (both 2D and 3D) through computer aided drafting packages.

**COURSE OUTCOMES:** After successful completion of the course, students will be able to:

- CO1: Apply the principles of engineering drawing, Methods and CAD tools to draw the Geometries, Curves and Orthographic projections used to communicate in engineering applications.
- CO2: Develop lateral surfaces of solids and draw Isometric views of given objects for engineering communication using principles of engineering drawing and CAD tools.
- CO3: Work independently / in groups & communicate effectively in oral and written forms.

#### **DETAILED SYLLABUS:**

##### **Introduction to Engineering Graphics and Design:**

Principles, significance -Conventions in drawing-lettering - BIS conventions-Dimensioning principles and conventional representations.

##### **Exercises:**

1. Practice exercise on Basic Lettering and Dimensioning
2. Practice exercise on Conventional representations

**Introduction to AutoCAD:** Basic drawing and editing commands: line, circle, rectangle, erase, view, undo, redo, snap, object editing, moving, copying, rotating, scaling, mirroring, layers, templates, polylines, trimming, extending, stretching, fillets, arrays, dimensions.

##### **Exercises:**

3. Practice exercise using basic drawing commands
4. Practice exercise using editing commands

##### **CONICS, CURVES, PROJECTION OF POINTS, LINES AND PLANES**

**Conics & Special Curves:** Conic sections including the rectangular hyperbola-eccentricity method only; Cycloid, Epicycloid and Hypocycloid, Involutives.

##### **Exercises:**

5. Practice exercises on Ellipse, Parabola, Hyperbola and Rectangular Hyperbola
6. Practice exercises on Cycloid, Epicycloid, Hypocycloid and Involutives

**Projection of points, lines and planes:** Projection of points in any quadrant, lines inclined to one or both planes, finding true lengths, angle made by line , Projections of regular plane surfaces.

**Exercises:**

7. Practice exercises on Projection of points
8. Practice exercises on projection of lines inclined to one plane
9. Practice exercises on projection of lines inclined to both planes
10. Practice exercises on Projections of regular plane surfaces

**PROJECTION OF SOLIDS AND SECTION OF SOLIDS**

**Projection of solids:** Projection of regular solids inclined to one plane.

**Sections of solids:** Section planes and sectional view of right regular solids- prism, cylinder, pyramid and cone, True shapes of the sections.

**Exercises:**

11. Practice exercises on Projections of regular solids
12. Practice exercises on Sections of solids

**DEVELOPMENT OF SURFACES**

**Development of surfaces:** Development of surfaces of right regular solids-prism, cylinder, pyramid, cone and their sectional parts.

**Exercises:**

13. Practice exercises on Development of surfaces of right regular solids

**ORTHOGRAPHIC AND ISOMETRIC PROJECTIONS**

**Orthographic Projections:** Systems of projections, conventions and application to orthographic projections.

**Isometric Projections:** Principles of isometric projection- Isometric scale; Isometric views: lines, planes, simple solids.

**Exercises:**

14. Practice exercises on Orthographic Projections
15. Practice exercises on Isometric Projections

**TEXT BOOKS:**

1. D. M. Kulkarni, A. P. Rastogi, A. K. Sarkar, *Engineering Graphics with AutoCAD*, PHI Learning Private Limited, New Delhi, Revised edition, 2010.
2. N. D. Bhatt and V. M. Panchal, *Engineering Drawing*, Charotar Publishing House, Gujarat, 51<sup>st</sup> edition, 2013.

**REFERENCE BOOKS/LABORATORY MANUALS:**

1. Sham Tickoo, *AutoCAD 2013 for Engineers and designers*, Dreamtech Press, 2013.
2. M.H. Annaiah & Rajashekar Patil, *Computer Aided Engineering Drawing*, New Age International Publishers, 4<sup>th</sup> edition, 2012.

## I B. Tech. – I Semester

### (19BT10531) PROGRAMMING FOR PROBLEM SOLVING LAB

(Common to CE, ME, CSE, CSSE and IT)

Int. Marks	Ext. Marks	Total Marks	L	T	P	C
50	50	100	-	-	2	1

**PRE-REQUISITES:** A course on Basic Mathematics

**COURSE DESCRIPTION:** The course is designed to provide hands on practice on Scratch programming and python programming for problem solving.

**COURSE OUTCOMES:** After successful completion of the course, students will be able to:

- CO1. Develop scripts using Scratch tool to simulate simple problems.
- CO2. Apply Python Constructs and Modules to develop solutions for real-life problems.
- CO3. Function effectively as an individual and in team to foster knowledge and creativity.
- CO4. Write and present a substantial technical report/ document effectively.

#### PRACTICAL EXERCISES:

- 1) a) Design a script in Scratch to simulate Airplane for take-off and land.  
b) Design a script in Scratch to make a sprite to ask the user to enter two different numbers and an arithmetic operator and then calculate and display the result.
- 2) a) Design a script in Scratch to calculate factorial of a given number.  
b) Design a script in Scratch to simulate Maze game. (Hint: To get Maze images refer <http://inventwithScratch.com/downloads/>)
- 3) a) Write a python script to read two integer numbers and perform arithmetic operations.  
b) Write a python script to evaluate following expressions by considering necessary inputs.  
i)  $ax^2 + bx + c$  ii)  $ax^5 + bx^3 + c$  iii)  $(ax + b) / (ax - b)$  iv)  $x - a / b + c$
- 4) a) Write a python script to convert given decimal number into octal, hexa decimal and binary.  
b) Write a python script to read four integer values separated with commas and display the sum of those four numbers.  
c) Write a python script to print "SVEC" with prefix of ten spaces by using `format()`.
- 5) a) Write a python script to calculate electricity bill based on following slab rates.

<u>Consumption units</u>	<u>Rate (in Rupees/Unit)</u>
0-100	4
101-150	4.6
151-200	5.2
201-300	6.3
Above 300	8

(Hint: To get Consumption units take current Meter reading, old meter reading

from the user as input)

- b) Print the following pattern using python script.

```

                1
              1 2 1
            1 2 3 2 1
          1 2 3 4 3 2 1
        1 2 3 4 5 4 3 2 1
```

- 6) a) Write a python script to read  $N$  student details like name, roll number, branch and age. Sort the student details based on their names and display.  
b) Write a python script to delete duplicate strings from a list of strings. (Insertion order should maintain after deleting duplicate string).  
c) Write a python script to read  $N$  number of student details into nested list and convert that as a nested dictionary.
- 7) a) Design a function that can perform sum of two or three or four numbers.  
b) Write a python script to implement towers of Hanoi problem.  
c) Write a Python function `primesquare(l)` that takes a nonempty list of integers and returns True if the elements of  $l$  alternate between perfect squares and prime numbers, and returns False otherwise. Note that the alternating sequence of squares and primes may begin with a square or with a prime. Here are some examples to show how your function should work.

```
>>>primesquare([4])
True
>>>primesquare([4,5,16,101,64])
True
>>>primesquare([5,16,101,36,27])
False
```

- 8) a) Write a python script to perform arithmetic operations on numpyarrays.  
b) Write a python script to perform following matrix operations using numpy.  
i) Dot product    ii) Matrix product    iii) Determinant    iv) Inverse
- 9) a) Write a python script to Create Pandas dataframe using list of lists.  
b) Write a python script to load data from a CSV file into a Pandas DataFrame and perform basic operations on it.
- 10) a) Draw a Scatter Plot by considering an appropriate data set.  
b) Draw histograms by considering an appropriate data set.
- 11)    **Mini Project-1**  
12)    **Mini Project-2**

#### TEXT BOOK:

1. R. Nageswara Rao, *Core Python Programming*, 2<sup>nd</sup> edition, Dreamtech Press, 2018.

## I B. Tech. - II semester

### (19BT2BS01) TRANSFORMATION TECHNIQUES AND LINEAR ALGEBRA

(Common to CE, ME, EEE, ECE, EIE, CSE, CSSE and IT)

Int. Marks	Ext. Marks	Total Marks	L	T	P	C
40	60	100	3	1	-	4

#### PRE-REQUISITES: -

**COURSE DESCRIPTION:** Fourier Series and Fourier Transforms; Laplace Transforms; Inverse Laplace Transforms; Linear Algebra-I (Matrices); Linear Algebra-II (Vector Spaces).

**COURSE OUTCOMES:** After successful completion of the course, students will be able to:

CO1: Apply the knowledge of Fourier and Laplace transform techniques to solve differential equations.

CO2: Analyze linear transformations and associated matrices to solve engineering problems by applying the knowledge of linear algebra.

#### DETAILED SYLLABUS:

##### UNIT- I: FOURIER SERIES AND FOURIER TRANSFORMS (09 Periods)

Fourier series: Determination of Fourier coefficients, Euler's formulae, convergence of Fourier series (Dirichlet's conditions), Fourier series in  $(0, 2l), (-l, l)$ ; Fourier series of even and odd functions; Half-range Fourier sine and cosine expansions in  $(0, l)$ ; Fourier integral theorem (statement only), Fourier sine and cosine integrals; Fourier transforms, Fourier sine and cosine transforms, Inverse Fourier transforms.

##### UNIT-II: LAPLACE TRANSFORMS (09 Periods)

Definition of Laplace transform, existence conditions, Laplace transform of standard functions, Properties of Laplace transforms, Laplace transforms of derivatives, Laplace transforms of integrals, multiplication by  $t^n$ , division by  $t$ , Laplace transform of periodic functions, Laplace transforms of unit step function and unit impulse function.

##### UNIT- III: INVERSE LAPLACE TRANSFORMS (09 Periods)

Inverse Laplace transform by different methods; Convolution theorem (without proof), inverse Laplace transforms by convolution theorem; Applications of Laplace transforms to ordinary differential equations of first and second order with constant coefficients.

##### UNIT- IV: LINEAR ALGEBRA-I (MATRICES) (09 Periods)

Rank of a matrix: echelon form; Linear systems of equations: solving system of Homogeneous and Non-Homogeneous equations; Eigen values and Eigen vectors of a matrix and properties (without proofs), Diagonalization of a matrix by orthogonal transformation; Quadratic forms and nature of the quadratic forms, reduction of quadratic form to canonical form by orthogonal transformation.

**UNIT- V: LINEAR ALGEBRA-II (VECTOR SPACES)****(09 Periods)**

Vector spaces, Linear dependence and independence of vectors, basis, dimension, Linear transformations (maps), range and kernel of a linear map, rank and nullity, inverse of a linear transformation, rank-nullity theorem (without proof), matrix associated with a linear map.

**Total Periods: 45****TEXT BOOKS:**

1. T. K. V. Iyengar, B. Krishna Gandhi, S. Ranganatham and M. V. S. S. N. Prasad, *Engineering Mathematics-II*, S. Chand & Company, 10<sup>th</sup> edition, 2016.
2. B. S. Grewal, *Higher Engineering Mathematics*, Khanna publishers, 44<sup>th</sup> edition, 2017.
3. David Poole, *Linear Algebra: A Modern Introduction*, Brooks/Cole, 2<sup>nd</sup> edition, 2005.

**REFERENCE BOOKS:**

1. B. V. Ramana, *Higher Engineering Mathematics*, Tata McGraw hill, 1<sup>st</sup> edition, 2017.
2. V. Krishna Murthy, Mainra and Arora: *An Introduction to Linear Algebra*, Affiliated East-West Press, 1993.

## I- B. Tech. - II Semester

### (19BT1BS02) **BIOLOGY FOR ENGINEERS**

(Common to CE, ME, CSE, CSSE and IT)

Int. Marks	Ext. Marks	Total Marks	L	T	P	C
40	60	100	2	-	-	2

#### **PRE-REQUISITES: -**

**COURSE DESCRIPTION:** Living Organisms; Proteins, Nucleic acids and Enzymes; Genetics and Molecular Biology; Recombinant DNA technology; Human Physiology and Applied Biology.

**COURSE OUTCOMES:** After successful completion of the course, students will be able to:

- CO1. Apply the basic knowledge of biology to understand the significance of various biological techniques.
- CO2. Identify the role of DNA in the molecular basis of information transfer and understand single gene disorders related to the health perspective.
- CO3. Apply the basic knowledge of bio-analytical devices and methods to assess health issues.

#### **DETAILED SYLLABUS:**

##### **UNIT-I: LIVING ORGANISMS (06 Periods)**

Comparison of biological organisms with man-made systems, Classification of living organisms, Cellular basis of life, differences between prokaryotes and eukaryotes, classification on the basis of carbon and energy sources, molecular taxonomy

##### **UNIT- II: PROTEINS, NUCLEIC ACIDS AND ENZYMES (06 Periods)**

Biomolecules, structure and functions of proteins and nucleic acids, Industrial applications of enzymes, Fermentation and its industrial applications

##### **UNIT- III: GENETICS AND MOLECULAR BIOLOGY (06 Periods)**

Mendel's laws, single gene disorders in humans, Genetic code, DNA replication, Transcription, Translation.

##### **UNIT-IV: RECOMBINANT DNA TECHNOLOGY (06 Periods)**

Recombinant DNA Technology: recombinant vaccines, transgenic microbes, plants and animals, animal cloning, biosensors, biochips.

##### **UNIT-V: HUMAN PHYSIOLOGY AND APPLIED BIOLOGY (06 Periods)**

Fundamentals of Human physiology, neurons, synaptic and neuromuscular junctions, Introduction to EEG, DNA fingerprinting, DNA Micro array and Genomics.

**Total Periods: 30**

**TEXT BOOKS:**

1. Rajiv Singal, Gaurav Agarwal, *Biology for Engineers*, CBS, 2019.
2. S. Sing and T. Allen, *Biology for Engineers*, Vayu Education of India, 2014.

**REFERENCE BOOKS:**

1. B. Alberts, A. Johnson et al., *The molecular biology of the cell*, Garland Science, 6<sup>th</sup> edition, 2014.
2. A. T. Johnson, *Biology for Engineers*, CRC press, 2011.

**ADDITIONAL LEARNING RESOURCES:**

1. Structure and function of Proteins: <https://nptel.ac.in/courses/104102016/16>
2. Enzymecatalysis: <https://nptel.ac.in/courses/103103026/module3/lec35/4.html>
3. Biochips: <https://nptel.ac.in/courses/112104029/3>



## I B. Tech. – II Semester

### (19BT2BS02) APPLIED PHYSICS

(Common to CE and ME)

Int. Marks	Ext. Marks	Total Marks	L	T	P	C
40	60	100	3	-	-	3

#### PRE-REQUISITES: -

**COURSE DESCRIPTION:** Fiber Optics; Acoustics and Ultrasonics; Kinematics and Kinetics; Thermal Physics; Modern Engineering Materials.

**COURSE OUTCOMES:** After successful completion of the course, students will be able to:

- CO1. Apply the knowledge of fiber optics, acoustics and ultrasonics to provide solutions for various engineering problems.
- CO2. Analyze and solve the problems associated with kinetics, kinematics and thermal physics.
- CO3. Demonstrate the knowledge on characteristics and applications of modern engineering materials.

#### DETAILED SYLLABUS:

##### UNIT-I: FIBER OPTICS

(08 Periods)

Introduction, structure of an optical fiber, total internal reflection, acceptance angle, acceptance cone and numerical aperture, modes of propagation, classification of optical fibers, V-number (qualitative), fabrication of optical fiber by double crucible technique, applications of optical fibers, sensors (temperature, displacement, liquid level detector).

##### UNIT-II: ACOUSTICS AND ULTRASONICS

(09 Periods)

**Acoustics** - Introduction, classification of sound, sound intensity level (decibel), reverberation, reverberation time, absorption coefficient and its determination, Sabine's formula (qualitative), factors affecting acoustics and their remedies, basic requirements of an acoustically good hall.

**Ultrasonics** - Introduction to ultrasonic waves, production of ultrasonic waves by piezoelectric method, magnetostriction method, detection of ultrasonics (qualitative), industrial applications (ultrasonic welding, ultrasonic soldering and ultrasonic drilling).

##### UNIT-III: KINEMATICS AND KINETICS

(10 Periods)

**Kinematics of particles** - Rectilinear motion (displacement-time curve, velocity-time curve, acceleration-time curve), curvilinear motion (velocity and angle of projection, equation of trajectory path, horizontal range) - inclined projection (equation of trajectory, maximum height, time of flight of projectile, horizontal range, angle of projection).

**Kinetics** - Bodies in rectilinear translation, kinetics of bodies rotating about fixed axis, work, energy, power, work-energy equation for translation.

**UNIT-IV: THERMAL PHYSICS****(08 Periods)**

Introduction, modes of heat transfer (conduction, convection and radiation), coefficient of thermal conductivity, rectilinear flow of heat along a uniform bar, thermal conductivity of bad conductor (Lee's disc method), heat conduction through compound media (materials in series and parallel).

**UNIT V: MODERN ENGINEERING MATERIALS****(10 Periods)**

**Metallic glasses** - Introduction, preparation of metallic glasses by RF sputtering technique, properties (structural, thermodynamic, mechanical, electrical, chemical and optical), applications of metallic glasses.

**Shape memory alloys (SMA)** - Introduction, shape memory effect and its types, characteristics of SMA, properties of NiTi alloy, applications of SMA.

**Composites** - Introduction, types and applications.

**Total Periods: 45****TEXT BOOKS:**

1. M. N. Avadhanulu, P. G. Kshirsagar, T. V. S Arun Murthy, *A Textbook of Engineering Physics*, S. Chand Publications, 11<sup>th</sup> edition, 2019.
2. S. S. Bhavikatti and K. G. Rajashekarappa, *Engineering Mechanics*, New Age International Publishers, 2<sup>nd</sup> edition, 2015.

**REFERENCE BOOKS:**

1. B. K. Pandey and S. Chaturvedi, *Engineering Physics*, Cengage Learning, 2012.
2. Brij Lal and N. Subrahmanyam, *Heat and Thermodynamics*, S. Chand and Company Ltd., 1995.

## I B. Tech. – II Semester

### (19BT10201) BASIC ELECTRICAL AND ELECTRONICS ENGINEERING

(Common to CE, ME, CSE, CSSE and IT)

Int. Marks	Ext. Marks	Total Marks	L	T	P	C
40	60	100	3	-	-	3

#### PRE-REQUISITES: -

**COURSE DESCRIPTION:** Principles of Electrical Systems; AC Machines; Semiconductor Devices and Op-Amps.

**COURSE OUTCOMES:** After successful completion of the course, students will be able to:

- CO1. Analyze electrical circuits by applying the conceptual knowledge of circuit elements.
- CO2. Demonstrate knowledge on various generation technologies, protection devices, safety procedures and BEE standards.
- CO3. Demonstrate knowledge on characteristics and applications of transformers and AC machines.
- CO4. Demonstrate knowledge on characteristics and applications of diode, BJT and Op-amps.

#### DETAILED SYLLABUS:

##### UNIT-I: PRINCIPLES OF ELECTRICAL SYSTEMS-I (09 Periods)

Basic electrical sources: DC-Battery, AC sources–Single loop generator; Single phase and three phase supply; Electrical circuit elements (R, L and C), Ohm’s law, Kirchhoff’s laws, Representation of sinusoidal waveforms, peak and RMS values, phasor representation, reactive power, apparent power, real power, energy and power factor.

##### UNIT-II: PRINCIPLES OF ELECTRICAL SYSTEMS-II (09 Periods)

Significance of Power factor and power factor correction, most economical power factor. Typical layout of electrical grid; Typical layout and operation of Hydro, Thermal and Solar Power Plants; Fuse, circuit breaker (MCB, MCCB, RCCB, ELCB), relay (elementary treatment); Inverter and UPS (block diagram approach only). Earthing – importance of earthing, pipe earthing and plate earthing; Safety measures. Energy Efficiency (Star rating) standards by BEE.

##### UNIT-III: TRANSFORMERS AND AC MACHINES (09 Periods)

Construction and working of a single phase transformer, EMF Equation; Construction and working of three phase induction motor, torque equation, torque-slip characteristics, applications; construction and working of a resistor start & capacitor start and run single phase induction motor, applications; Construction and working of synchronous machine, applications.

##### UNIT-IV: SEMICONDUCTOR DEVICES (10 Periods)

PN Junction diode, Characteristics, applications - half wave and full wave rectifier. Zener diode, characteristics, application–Regulator. BJT- operation, configurations, characteristics, applications - switch and amplifier.

**UNIT-V: OP-AMPS****(08 Periods)**

Operational Amplifier: Block diagram of Op-Amp, equivalent circuit, Op-Amp AC and DC Characteristics, Inverting and Non-Inverting modes. Applications - Adder, Comparator, Integrator and Differentiator.

**Total Periods: 45****TEXT BOOKS:**

1. Ashfaq Hussain, *Fundamentals of Electrical Engineering*, Dhanpatrai & Co. (P) Ltd., 3<sup>rd</sup> edition, New Delhi, 2009.
2. R. L. Boylestad and Louis Nashelsky, *Electronics Devices and Circuits*, PHI, 11<sup>th</sup> edition, 2009.

**REFERENCE BOOKS:**

1. M. S. Naidu, S. Kamakshaiah, *Introduction to Electrical Engineering*, Tata McGraw-Hill Education, New Delhi, 2007.
2. D. Roy Chowdhury, *Linear Integrated Circuits*, New Age International Pvt. Ltd., 4<sup>th</sup> edition, 2011.

## I B. Tech. – II Semester

### (19BT20101) CIVIL ENGINEERING MATERIALS AND CONCRETE TECHNOLOGY

Int. Marks	Ext. Marks	Total Marks	L	T	P	C
40	60	100	3	-	-	3

**PRE-REQUISITES:** Engineering Chemistry

**COURSE DESCRIPTION:** Stones; Bricks; Tiles; Timber; Miscellaneous Materials in Construction; Cement, Admixtures and Aggregates; Fresh and Hardened Concrete; Elasticity, Shrinkage, Creep and Concrete Mix Design.

**COURSE OUTCOMES:** After successful completion of the course, students will be able to:

- CO1 Analyze civil engineering materials, fresh and hardened concrete using different tools/techniques for civil engineering construction considering codes of practice, environment and sustainability.
- CO2 Design a concrete mix for civil engineering construction considering appropriate codes of practice.

#### DETAILED SYLLABUS:

##### UNIT-I: STONES, BRICKS AND TILES

(09 Periods)

**Stones:** Properties of building stones and structural requirements, Classification of stones, Stone quarrying, Blasting and dressing of stones.

**Bricks and Tiles:** Composition of good brick earth, Manufacture of bricks, Qualities of a good brick, Efflorescence in bricks, Classification of bricks, Characteristics of good tile, Manufacturing methods, Types of tiles.

##### UNIT-II: TIMBER AND MISCELLANEOUS MATERIALS FOR CONSTRUCTION

(08 Periods)

**Timber:** Structure, Properties, Seasoning of timber, Classification of various types of wood used in buildings, Defects in timber, Decay of timber, Mechanical treatment, Alternative materials for wood, Paints, Varnishes, Bituminous wooden products in construction.

**Miscellaneous Materials for Construction:** Use of Materials like galvanized iron, steel, aluminum, glass, bituminous materials, rubber, fiber-reinforced plastics, ceramic products, asbestos and their quality; Modern building materials; Building materials for low cost housing, Utilisation of waste for alternative building materials, Sustainable materials in construction.

##### UNIT-III: CEMENT, ADMIXTURES AND AGGREGATES

(09 Periods)

**Cement and Admixtures:** Ingredients of cement, Manufacture of OPC, Types of cement and their properties, Grades of Cement, Various field and laboratory tests on cement, Admixtures - mineral admixtures, chemical admixtures.

**Aggregates:** Classification of aggregate, Physical properties, Mechanical properties, Bond strength, Bulking of sand, Deleterious substance in aggregate, Soundness of aggregate, Alkali aggregate reaction, Sieve analysis, Gradation, Maximum aggregate size.

#### **UNIT-IV: FRESH AND HARDENED CONCRETE**

**(09 periods)**

**Fresh Concrete:** Ingredients of cement concrete and their importance, Manufacture of concrete, Workability, Factors affecting, Measurement of workability, Setting times of concrete, Effect of time and temperature on workability, Segregation and bleeding, Ready mix concrete, Quality of mixing water.

**Hardened Concrete:** Water/Cement ratio, Abram's Law, Gel space ratio, Curing, Nature of strength of concrete, Maturity concept, Strength in tension and compression, Factors affecting strength, Tests on hardened concrete, Relation between compressive and tensile strength, Non-destructive testing methods – Rebound hammer, ultrasonic pulse velocity method, codal provisions.

#### **UNIT – V: ELASTICITY, SHRINKAGE, CREEP AND CONCRETE MIX DESIGN**

**(10 Periods)**

**Elasticity, Shrinkage and Creep:** Modulus of elasticity, Dynamic modulus of elasticity, Poisson's ratio, Shrinkage – Types, factors; Creep of concrete - Factors, Relation between creep and time, Effects.

**Concrete Mix Design:** Factors in the choice of mix proportions, Durability of concrete, Quality control of concrete, Statistical methods, Acceptance criteria, Proportioning of concrete mixes by various methods – ACI method and IS 10262 method.

**Total Periods: 45**

#### **TEXT BOOKS:**

1. S. K. Duggal, *Building Materials*, New Age International Publishers, 4<sup>th</sup> edition, 2010.
2. M. S. Shetty, *Concrete Technology*, S. Chand and Company Ltd., 7<sup>th</sup> edition, 2011.

#### **REFERENCES:**

1. P. C. Varghese, *Building Materials*, Prentice-Hall of India Private Ltd., New Delhi, 2011.
2. A. M. Neville, *Properties of Concrete*, 5<sup>th</sup> edition, John Wiley and Sons, New Delhi, 2012.

#### **ADDITIONAL LEARNING RESOURCES:**

1. M. L. Gambhir, *Concrete Technology*, 3<sup>rd</sup> edition, Tata McGraw-Hill Publishers, New Delhi, 2008.
2. A. R. Santha Kumar, *Concrete Technology*, 7<sup>th</sup> edition, Oxford University Press, New Delhi, 2011.

## I B. Tech. – II Semester

### (19BT20102) ENGINEERING MECHANICS

Int. Marks	Ext. Marks	Total Marks	L	T	P	C
40	60	100	3	1	-	4

#### PRE-REQUISITES: -

**COURSE DESCRIPTION:** Statics of Particles and Rigid Bodies; Support Reactions; Analysis of Perfect Frames; Friction; Centroid, Centre of Gravity and Moment of Inertia; Simple Stresses and Strains; Thin and Thick Cylinders.

**COURSE OUTCOMES:** After successful completion of the course, students will be able to:

CO1. Analyze engineering problems related to statics of particles and rigid bodies; friction; sectional properties; simple stresses and strains, for effective solutions.

CO2. Design cylinders for different engineering applications ensuring safety.

#### DETAILED SYLLABUS:

##### UNIT – I: STATICS

(10 Periods)

**Statics of Particles:** Basic concepts, System of units, System of concurrent coplanar forces in plane, Resultant of forces, Laws of mechanics, Equilibrium of forces, Lami's theorem, Vectorial representation of forces.

**Statics of Rigid Bodies:** Moment of a force, Varignon's theorem, Moment of a couple, Vectorial representation of moments and couples, Coplanar non-concurrent forces, Equilibrium of rigid bodies, Types of supports and loads, Types of frames, Perfect frame analysis, Method of joints, Method of sections, Principle of virtual work.

##### UNIT – II: FRICTION

(08 Periods)

Frictional force, Types of friction, Laws of friction, Co-efficient of friction, Angle of friction, Angle of repose, Cone of friction, Applications: Body on horizontal/inclined plane, Two bodies in contact, Ladder friction, Wedge friction.

##### UNIT – III: CENTROID, CENTRE OF GRAVITY AND MOMENT OF INERTIA

(09 Periods)

Centroids of simple and composite areas, Centre of gravity of bodies, Theorems of Pappus and Guldinus, Parallel axis and perpendicular axis theorems, Moment of Inertia of Composite areas, Radius of gyration – Section modulus, Mass Moment of Inertia of simple and composite masses.

##### UNIT – IV: SIMPLE STRESSES AND STRAINS

(10 Periods)

Elasticity and plasticity, Types of stresses and strains, Hooke's law, Stress-strain diagram for mild steel, Working stress, Factor of safety, Lateral strain, Poisson's ratio, Volumetric strain, Types of elastic moduli and relations, Bars of varying section, Composite bars, Temperature stresses, Strain energy - Gradual, sudden and impact loadings, Simple applications.

## **UNIT – V: THIN AND THICK CYLINDERS**

**(08 Periods)**

**Thin Cylinders:** Thin cylindrical shells, Longitudinal and circumferential stresses; Hoop, Longitudinal and volumetric strains; Changes in dimensions of thin cylinders.

**Thick Cylinders:** Lamé's theory, Distribution of hoop and radial stresses across thickness, Design of thick cylinders, Compound cylinders, Difference of radii for shrinkage.

**Total Periods: 45**

### **TEXT BOOKS:**

1. S. S. Bhavikatti and K. G. Rajashekarappa, *Engineering Mechanics*, New Age International (P) Ltd., 3<sup>rd</sup> edition, 2009.
2. Punmia, B. C., Ashok Kumar Jain and Arun Kumar Jain, *Mechanics of Materials*, Laxmi Publications Pvt. Ltd., 2001.

### **REFERENCE BOOKS:**

1. J. L. Meriam and L. G. Kraige, *Engineering Mechanics: Statics (Vol. 1), Dynamics (Vol. 2)*, John Wiley & Sons Ltd., 5<sup>th</sup> edition, 2008.
2. S. Rajasekaran and G. Sankara subramanian, *Engineering Mechanics – Statics and Dynamics*, Vikas Publishing House Pvt. Ltd., 3<sup>rd</sup> edition, 2009.
3. Bhavikatti, S. S., *Strength of Materials*, Vikas Publishing House, 3<sup>rd</sup> edition, 2010.
4. Junnarkar, S. B. and Shah, H. J., *Mechanics of Structures – Vol. I (Strength of Materials)*, Charotar Publishing House Pvt. Ltd., 27<sup>th</sup> Revised and enlarged edition, 2008.

### **ADDITIONAL LEARNING RESOURCES:**

1. Arthur P. Boresi and Richard J. Schmidt, *Engineering Mechanics - Statics and Dynamics*, Cengage Learning, 1<sup>st</sup> edition, Indian edition, 2008.
2. K. Vijaya Kumar Reddy and J. Suresh Kumar, *Singer's Engineering Mechanics - Statics and Dynamics*, BS Publications, 3<sup>rd</sup> edition, 2010.
3. S. Timoshenko, D. H. Young and J. V. Rao, *Engineering Mechanics*, Tata McGraw-Hill Education Pvt. Ltd., Revised 4<sup>th</sup> edition, Special Indian edition, 2007.
4. Rajput, R. K., *Strength of Materials (Mechanics of Solids)*, S. Chand & Company LTD, 5<sup>th</sup> edition, 2006.
5. Ramamrutham, S. and Narayanan, R., *Theory of Structures*, 9<sup>th</sup> edition, Dhanpat Rai Publishing Co. Ltd., 2014.
6. Basu, A. R., *Strength of Materials*, Dhanpat Rai & Co. (P) LTD., 2<sup>nd</sup> Revised edition, 2015.



## I B. Tech. – II Semester

### (19BT2BS31) APPLIED PHYSICS LAB

(Common to CE and ME)

Int. Marks	Ext. Marks	Total Marks	L	T	P	C
50	50	100	-	-	2	1

#### PRE-REQUISITES: -

**COURSE DESCRIPTION:** Determination of Moment of Inertia, Elastic Moduli, and Thermal properties of materials; Estimation of carrier concentration and energy gap of a semiconductor; Verification of Newton's Law of Cooling; Characteristics of Optical Fiber;

**COURSE OUTCOMES:** After successful completion of the course, students will be able to:

CO1. Demonstrate the experimental procedures to compute the frequency of a tuning fork, hall coefficient, energy gap, moment of inertia, rigidity modulus and thermal conductivity of materials.

CO2. Apply skills to plot various characteristic curves of an optical Fiber and also determine thermal conductivity, thermo emf and energy gap.

CO3. Work independently and in teams to solve problems with effective communication.

A minimum of **Ten** experiments are to be conducted among the following:

#### List of Experiments:

1. Determination of moment of inertia of a bar and acceleration due to gravity - Compound Pendulum.
2. Moment of inertia of a Flywheel.
3. Bifilar Pendulum - Moment of inertia of a rectangular body.
4. Melde's Experiment – Determine the frequency of electrically driven tuning fork.
5. Determination of thermal conductivity of a good conductor (Forbe's Apparatus).
6. Determination of thermal conductivity of a bad conductor (Lee's disc method).
7. Thermal Expansion of Solids - Bimetallic Strip.
8. Study the characteristics of an optical Fiber.
9. Verification of Newton's Law of Cooling for any two liquids.
10. Determination of number of charge carriers per unit volume and hall coefficients of a given material using Hall Effect.
11. Rigidity Modulus of a material of a wire - Torsional Pendulum
12. Thermocouple - Seebeck Effect.
13. Determine the energy gap of a material by varying temperatures.

#### REFERENCES:

1. Balasubramanian S, Srinivasan M.N and Ranganathan, *A Text book of Practical Physics*, R, Sultan Chand & Sons, 2017.  
<https://vlab.amrita.edu/index.php?sub=1&brch=194&sim=354&cnt=1>

## I B. Tech. – II Semester

### (19BT10231) BASIC ELECTRICAL AND ELECTRONICS ENGINEERING LAB

(Common to CE, ME, CSE, CSSE and IT)

Int. Marks	Ext. Marks	Total Marks	L	T	P	C
50	50	100	-	-	2	1

**PRE-REQUISITES:** Physics at intermediate level.

**COURSE DESCRIPTION:** Practical investigations on Electrical circuits, AC Machines, Semiconductor Devices and Op-Amps.

**COURSE OUTCOMES:** After successful completion of the course, student will be able to:

CO1. Analyze, measure, interpret and validate the practical observations by applying the fundamental knowledge of electrical circuits, machines and electronic devices.

CO2. Design Op-amp based amplifier, voltage summer and integrator circuits for desired specifications.

CO3. Work independently and in teams to solve problems with effective communication.

#### List of Experiments:

Minimum Ten experiments are to be conducted.

1. Measurement of electrical quantities (AC & DC) using Voltmeter, Ammeter and Wattmeter.
2. Verification of Ohm's law and Kirchhoff's laws.
3. Circuit
  - (a) with one lamp controlled by one switch and provision of 2-pin or 3-pin socket PVC surface conduit system.
  - (b) With two lamps controlled by two switches with PVC surface conduit system.
  - (c) for Stair case wiring and Go down wiring.
4. Measurement of Power factor and its improvement.
5. Load test on 1-Phase Transformer.
6. Brake test on 3-Phase Induction Motor.
7. Brake test on 1- phase induction motor.
8. VI Characteristics of PN and Zener Diodes.
9. Ripple factor and load regulations of rectifier with and without filters.
10. Input and output characteristics of CE configuration.
11. Design of inverting and non-inverting amplifiers using op-amp.
12. Design of voltage summer and integrator using op-amp.
13. Soldering practice.

#### REFERENCES BOOKS/ LAB MANUALS:

1. P. S. Dhogal, *Basic Practicals in Electrical Engineering*, Standard Publishers, 2004.
2. Yannis Tsvividis, *A First Lab in Circuits and Electronics*, Wiley, 1<sup>st</sup> edition., 2001

#### ADDITIONAL LEARNING RESOURCES:

1. [www.vlab.co.in](http://www.vlab.co.in), Virtual Electric Circuits Lab, A initiative of MHRD under NMEICT.
2. [www.vlab.co.in](http://www.vlab.co.in), Basic Electronics Lab, A initiative of MHRD under NMEICT.
3. <https://nptel.ac.in/courses/117106108/>
4. <https://ocw.mit.edu/high-school/physics/exam-prep/electric-circuits/>
5. <https://nptel.ac.in/courses/108105017/>
6. <https://nptel.ac.in/courses/108108112/>  
<https://nptel.ac.in/courses/117107094/>

## I B. Tech. – II Semester

### (19BT20331) ENGINEERING WORKSHOP

(Common to CE, ME, CSE, CSSE and IT)

Int. Marks	Ext. Marks	Total Marks	L	T	P	C
50	50	100	-	-	2	1

#### PRE-REQUISITES: -

**COURSE DESCRIPTION:** Knowledge on various workshop hand and power tools; hands on experience in different manufacturing trades such as fitting, carpentry, sheet metal forming and foundry; Demonstration on dismantling and assembling of various two wheeler parts, power tools in machining and metal joining, basics of plumbing and working of 3D printer.

**COURSE OUTCOMES:** After successful completion of the course, students will be able to:

- CO1. Design and model various basic prototypes in the trade of fitting such as square/half round mating, V- mating and dovetail mating from the given MS work pieces using fitting tools.
- CO2. Develop different prototypes in the carpentry trade such as cross lap joint, dovetail / bridle joints and Mortise and Tenon joint using carpentry tools.
- CO3. Design and model different prototypes in the sheet metal forming trade such as rectangular tray, square vessel/cylinder, Funnel as per the dimensions using sheet metal forming tools.
- CO4. Develop sand mold using single piece pattern and split piece pattern in the foundry trade using foundry tools.
- CO5. Demonstrate the knowledge on automobile parts, power tools, plumbing operation, 3D printing technology involved in different engineering applications.
- CO6. Work independently / in groups & communicate effectively in oral and written forms.

#### DETAILED SYLLABUS:

**FITTING:** Conduct a detailed study on various aspects in fitting trade which includes the details of fitting operations, safety precautions, types of tools, tool holders, miscellaneous tools, care and maintenance of hand tools, marking and measurement tool, and finishing tool.

##### List of Exercises:

1. Make a square/half round mating from the given MS work pieces
2. Make a V- mating from the given MS work pieces
3. Make a dovetail mating from the given MS work pieces

**CARPENTRY:** Conduct a detailed study on various aspects in carpentry trade which includes the details of types of wood, carpentry tools, wood working techniques, types of joints, safety precautions, and care and maintenance of tools.

##### List of Exercises:

1. Prepare a cross lap joint
2. Prepare dovetail / bridle joints

3. Prepare a Mortise and Tenon joint.

**SHEET METAL FORMING:** Conduct a detailed study on various aspects in sheet metal forming which includes the details of sheet materials, hand tools, sheet metal fabrication, and safety and precautions

**List of Exercises:**

1. Fabricate a rectangular tray as per the dimensions
2. Fabricate square vessel/cylinder as per the dimensions
3. Fabricate a Funnel as per the dimensions

**FOUNDRY:** Conduct a detailed study on various aspects in foundry which includes the details of moulding sand, properties of moulding sand, types of patterns and pattern, materials, foundry tools, and safety and precautions

**List of Exercises:**

1. Prepare a sand mold, using the given single piece pattern (stepped pulley/cube)
2. Prepare a sand mold, using the given split piece pattern (pipe bent/dumbbell)

**DEMONSTRATION:**

1. Demonstrate the dismantling and assembling of various two wheeler parts
2. Demonstrate the usage of power tools.
3. Demonstrate the plumbing operation and identify the essential tool and materials required for plumbing.
4. Demonstrate the working of 3D printer

Note: Student shall perform any **Twelve Exercises**

**REFERENCE BOOKS/LABORATORY MANUALS:**

1. P. Kannaiah and K. L. Narayana, *Workshop Manual*, SciTech Publishers, 2009.
2. K. Venkata Reddy, *Workshop Practice Manual*, BS Publications, 2008.
3. V. Ramesh Babu, *Engineering Workshop Practice*, V R B Publishers Private Limited, 2009.

**ADDITIONAL LEARNING RESOURCES:**

1. R. K. Jain, *Production Technology*, Khanna Publishers, 17<sup>th</sup> edition, 2012.
2. Kalpakjian, Serape, *Manufacturing Engineering and Technology*, Pearson Education, 7<sup>th</sup> edition, 2014.

## I B. Tech. – II Semester

### (19BT20131) ENGINEERING GEOLOGY LAB

Int. Marks	Ext. Marks	Total Marks	L	T	P	C
50	50	100	-	-	2	1

#### PRE-REQUISITES: -

**COURSE DESCRIPTION:** Study of physical properties and identification of minerals and rocks; Rock forming minerals; Ore forming minerals; Igneous rocks; Sedimentary rocks; Metamorphic rocks; Geological maps; Problems on structural geology; Norm form calculations; Resistivity survey.

**COURSE OUTCOMES:** After successful completion of the course, students will be able to:

- CO1. Identify minerals and rocks using appropriate tools/techniques in order to understand the impact of geological features on civil engineering projects
- CO2. Analyze structural geology problems for feasible inferences associated with civil engineering projects.
- CO3. Develop and interpret geological sections from the geological maps for the benefit of civil engineering projects.
- CO4. Perform individually or in a team besides communicating effectively in written, oral and graphical forms on geological information.

#### DETAILED SYLLABUS:

Introduction to Engineering Geology in Civil Engineering, Mineralogy (properties and identification of minerals), Petrology (properties and identification of rocks), Geological maps, Structural geology problems and Geophysical studies.

#### LIST OF PRACTICAL EXERCISES:

##### A) MINERALS

1. Study of physical properties and identification of rock forming minerals
2. Study of physical properties and identification of ore forming minerals

##### B) ROCKS

3. Study of physical properties and identification of common igneous rocks
4. Study of physical properties and identification of common sedimentary rocks
5. Study of physical properties and identification of common metamorphic rocks

##### C) GEOLOGICAL MAPS

6. Study of geological maps, drawing and interpretation of geological sections in horizontal beds
7. Study of geological maps, drawing and interpretation of geological sections in vertical beds
8. Study of geological maps, drawing and interpretation of geological sections in beds with fault plane
9. Study of geological maps, drawing and interpretation of geological sections in beds with folding

##### D) STRUCTURAL GEOLOGY PROBLEMS

10. Thickness
11. Strike and dip

12. Bore hole

**E) NORM FORM CALCULATIONS**

13. Normative minerals analysis(not for the examination)

**F) GEOPHYSICAL STUDIES**

14. Electrical resistivity survey (not for the examination)

15. Seismic surveys (not for the examination)

**REFERENCE BOOKS/LABORATORY MANUALS:**

1. "*Engineering Geology Laboratory Manual (SVEC 19 Regulations)*", Department of Civil Engineering, Sree Vidyanikethan Engineering College, Tirupati.

## I B. Tech. - II Semester

### (19BT1AC01) SPOKEN ENGLISH

(Audit Course)

(Common to CE, ME, CSE, CSSE and IT)

Int. Marks	Ext. Marks	Total Marks	L	T	P	C
-	-	-	2	-	-	-

#### PRE-REQUISITES: -

**COURSE DESCRIPTION:** Functional English; Vocabulary Building; Functional Grammar-I; Functional Grammar – II; Communication Skills.

**COURSE OUTCOMES:** After successful completion of the course, students will be able to:

- CO1. Demonstrate knowledge of grammar and vocabulary in writing effective formal letters and e-mails.
- CO2. Communicate effectively by applying appropriate speaking and writing techniques by examining and applying functional English.

#### DETAILED SYLLABUS:

##### UNIT- I: FUNCTIONAL ENGLISH (06 Periods)

Introduction - Functional Spoken English; Self Introduction; **Listening – Speaking:** Do's and Don'ts; **Expressing:** Ability / Admiration / Agreement / Annoyance / Appreciation / Pleasure / Sarcasm / Satisfaction / Surprise / Approval / Certainty / Doubt / Gratitude / Possibility / Fear / Worry / Condolences; **Asking for:** Advice / Clarification / Direction / Information / Permission; **Making:** Predictions / recommendations.

##### UNIT- II: VOCABULARY BUILDING (06 Periods)

Introduction: Vocabulary for day-to-day conversations; Vegetables / Groceries / Fruits / Weather; Parts of a Human body / Dresses / Furniture / Relations; Birds / Cries of Animals; Food / Hospitality / Houses / Rooms / Tools; Airport / News Paper / Books / Gems; Corporate Vocabulary / Jobs / Occupations / Diseases; British / American spelling; Slang Words and Technical Jargon.

##### UNIT III -FUNCTIONAL GRAMMAR - I (06 Periods)

Parts of Speech, Verb forms; Tenses; Voice; Speech.

##### UNIT-IV: FUNCTIONAL GRAMMAR - II (06 Periods)

Universal Auxiliaries; Sentence Structure - WH - Questions - How to frame Questions and give answers; Question Tags; Subject and verb agreement; Spotting Errors.

##### UNIT-V: COMMUNICATION SKILLS: (06 Periods)

Polite, Courteous and Diplomatic expressions; Good Manners and Etiquette; Conversation Techniques; Narrating Stories.

**Total Periods: 30**

**TEXT BOOKS:**

1. L. Adinarayana and V. Prakasam, *Spoken English*, Neelkamal Publications Pvt. Ltd., New Delhi, 2008.
2. Ram Bhasker Raju, *The Complete Book on Spoken English*, Goutham Buddha Publications, Hyderabad, 2002.

**REFERENCE BOOKS:**

1. Sabina Pillai, *Spoken English for my World*, Oxford University Press, New Delhi, 2016.
2. K. R. Lakshminarayanan, *Speak in English*, Scitech Publications, Chennai, 2009.

**ADDITIONAL LEARNING RESOURCES:**

1. <https://www.britishcouncil.in/programmes/english-partnerships/state/skills-projects/AP-English-Skills>.
2. <https://www.fluentu.com/blog/english/websites-to-learn-english>



## II B. Tech. - I Semester

### (19BT3BS01) NUMERICAL METHODS, PROBABILITY AND STATISTICS

(Common to CE, ME, CSE, CSSE and IT)

Int. Marks	Ext. Marks	Total Marks	L	T	P	C
40	60	100	3	1	-	4

#### PRE-REQUISITES: -

**COURSE DESCRIPTION:** Numerical solutions of equations; interpolation; numerical differentiation and integration; random variables; mathematical expectations; probability distributions; test of hypothesis.

**COURSE OUTCOMES:** After successful completion of the course, students will be able to:

- CO1 Analyse the data and develop skills to solve equations and integrals by applying numerical methods.
- CO2 Demonstrate knowledge in statistics and analyse the data for validations by applying statistical testing methods and distributions.

#### DETAILED SYLLABUS

##### UNIT-I: NUMERICAL SOLUTIONS OF EQUATIONS AND INTERPOLATION

(08 Periods)

Solutions of algebraic and transcendental equations: Regula-falsi method, Newton-Raphson method; Interpolation: Forward and backward differences, interpolation using Newton's forward and backward difference formulae, Lagrange's interpolation formula, partial fractions using Lagrange's interpolation formula.

##### UNIT- II: NUMERICAL DIFFERENTIATION AND INTEGRATION (09 Periods)

Numerical differentiation using Newton's forward and backward interpolation formulae; Numerical integration using Simpson's  $1/3^{\text{rd}}$  and  $3/8^{\text{th}}$  rules; Numerical solutions of first order ordinary differential equations using Taylor's series method, fourth order Runge-Kutta method.

##### UNIT-III: RANDOM VARIABLES AND MATHEMATICAL EXPECTATIONS

(08 Periods)

Random Variables: Discrete and continuous random variables, distribution function of random variable, properties, probability mass function, probability density function; mathematical expectation, properties of mathematical expectation, mean and variance.

##### UNIT-IV: PROBABILITY DISTRIBUTIONS

(09 Periods)

Discrete probability distributions: Binomial, Poisson- mean, variance, standard deviation (without derivations); Continuous probability distributions: Normal, uniform and exponential distributions- mean, variance, standard deviation (without derivations), area under the normal curve.

**UNIT-V: TEST OF HYPOTHESIS****(11 Periods)**

Population and sample, parameter and statistic, null and alternative hypothesis, Type I and Type II errors, level of Significance, critical region, degrees of freedom; Large sample test: Tests of significance for proportions and means; Small sample test: Student's t-test- single mean, difference of means; F-test for equality of population variance; Chi-Square test for independence of attributes.

**Total Periods: 45*****Topics for self-study are included in lesson plan*****TEXT BOOKS:**

1. T. K. V. Iyengar, B. Krishna Gandhi, S. Ranganatham and M. V. S. S. N. Prasad, *Mathematical Methods*, S. Chand & Company, 5<sup>th</sup> edition, 2016.
2. T. K. V. Iyengar, B. Krishna Gandhi, S. Ranganatham and M. V. S. S. N. Prasad, *Probability and Statistics*, S. Chand & Company, 5<sup>th</sup> edition, 2016.

**REFERENCE BOOKS:**

1. B. S. Grewal, *Higher Engineering Mathematics*, Khanna Publishers, 44<sup>th</sup> edition, 2017.
2. P. Kandasamy, K. Thilagavathy, K. Gunavathi, *Numerical Methods*, S. Chand and Company, 2<sup>nd</sup> edition, Reprint 2012.
3. S. C. Gupta and V. K. Kapoor, *Fundamentals of Mathematical Statistics*, Sultan Chand and Sons Publications, 11<sup>th</sup> edition, 2012.

## II B. Tech. – I Semester

### (19BT30101) CONSTRUCTION, PLANNING AND PROJECT MANAGEMENT

Int. Marks	Ext. Marks	Total Marks	L	T	P	C
40	60	100	3	-	-	3

**PRE-REQUISITES:** Course on Civil Engineering Materials and Concrete Technology

**COURSE DESCRIPTION:** Masonry and Foundations; Building Components; Finishings; Shoring; Scaffolding; Form Work; Organization and Resource Management; Project Management; Network Development; PERT and CPM.

**COURSE OUTCOMES:** On successful completion of this course, the students will be able to:

- CO1 Characterize masonry, foundations and building components using various tools and techniques besides communicating effectively in graphical form.
- CO2 Analyze finishings, shoring, scaffolding and form work using various tools and techniques and through continuous learning considering safety, environment and sustainability.
- CO3 Analyze organization and resource management through various tools and techniques in accordance with legislative laws and amendments in construction practice ensuring safety and sustainability.
- CO4 Develop charts and event networks using appropriate tools and techniques for solving complex construction project management problems besides communicating effectively in graphical form.
- CO5 Develop event networks for analyzing critical path by using CPM and PERT techniques and interpret various parameters for effective project management besides communicating effectively in graphical form.

#### DETAILED SYLLABUS

##### UNIT – I: MASONRY, FOUNDATIONS AND BUILDING COMPONENTS (08 Periods)

**Masonry and Foundations:** Types of masonry, English and Flemish bonds, Rubble and ashlar masonry, Cavity walls, Partition walls, Foundations, Shallow foundations, Spread, Combined, Strap and mat footings.

**Building Components:** Lintels, Arches, Vaults, Stair cases, Different types of floors, Concrete, Mosaic, Terrazzo floors, Pitched, Flat and curved roofs, Lean-to-Roof, Coupled roofs, Trussed roofs, King and Queen post trusses, RCC Roofs, Madras Terrace/Shell Roofs.

##### UNIT - II: FINISHINGS, SHORING, SCAFFOLDING AND FORM WORK (07 Periods)

**Finishings:** Damp proofing, Water proofing, Termite proofing, Fire proof materials used, Plastering, Pointing, White washing and distempering, Painting, Constituents of a paint, Types of paints, Painting of new/old wood, Varnish.

**Shoring, Scaffolding and Form Work:** Types, Erection methodology, Latest equipment, Safety precautions.

##### UNIT - III: ORGANIZATION AND RESOURCE MANAGEMENT (10 Periods)

**Organization:** Types, Merits and demerits of different types of organization, Labour legislation in India, Workmen's compensation act of 1923 and minimum wages act of 1948, and subsequent amendments, Safety in construction.

**Resource Management: Manpower:** Resource smoothing, Resource leveling, establishing workers productivity. **Materials:** Objectives of material management, Costs, Functions of material management departments, ABC classification of materials, Inventory of materials, Material procurement, Stores management. **Machinery:** (Basics only) Classification of construction equipment, Earth moving Equipment, Excavation equipment, Hauling equipment, Earth compaction equipment, Hoisting equipment, Concreting plant and equipment, Selection of equipment, Task consideration, Cost consideration, Factors affecting the selection, Factors affecting cost owning and operating the equipment, Equipment maintenance.

#### **UNIT - IV: PROJECT MANAGEMENT AND NETWORK DEVELOPMENT (11 Periods)**

**Project Management:** Project planning, Scheduling, Controlling, Role of decision in project management, Techniques for analyzing alternatives, Operation research, Methods of planning and programming problems, Development of bar chart - Illustrative examples, Shortcomings of bar charts and remedial measures; Milestone charts, Development of PERT network problems.

**Network Development:** Introduction, Event, Activity, Dummy, Graphical guidelines for network, Common partial situations in network, Numbering the events, Cycles problems, Planning for network construction, Modes of network construction, Steps in development of network, Work breakdown structure, Hierarchies, Illustrative examples.

#### **UNIT – V: PERT AND CPM**

**(09 Periods)**

Network analyses, PERT, Slack, Critical path, Illustrative examples, Probability of meeting scheduled date problems, CPM process, CPM networks, Activity time estimate, Earliest event time, Latest allowable occurrence time, Combined tabular computations for  $T_E$  and  $T_L$ , Start and finish times of activity, Float, Critical activities and critical path, Resource allocation, leveling, Crashing, Illustrative examples.

**Total Periods: 45**

**Topics for self-study are provided in the lesson plan.**

#### **TEXT BOOKS:**

1. K. K. Chitkara, *Construction Project Management: Planning, Scheduling and Controlling*, 3<sup>rd</sup> Edition, Tata McGraw Hill Education Pvt. Ltd., 2014.
2. B. C. Punmia, K. K. Khandelwal, *Project Planning and Control with PERT and CPM*, 4<sup>th</sup> Edition, Lakshmi Publications (P). Ltd., 2010.

#### **REFERENCE BOOKS:**

1. Jha, *Construction Project Management*, 1<sup>st</sup> Edition, Pearson Publications, 2011.
2. R. Chudly, Roger Greno, Mike Hurst and Simon Topliss, *Construction Technology – Vol. I and Vol. II*, 5<sup>th</sup> Edition, Longman, 2011.
3. S. Seetharaman, *Construction Engineering and Management*, 3<sup>rd</sup> Edition, Umesh Publications, 2010.
4. B.C. Punmia, Ashok Kumar Jain and Arun Kumar Jain, *Building Construction*, 10<sup>th</sup> Edition, Laxmi Publications (P) Ltd., 2010.

#### **ADDITIONAL LEARNING RESOURCES:**

1. Srinath L. S., *PERT and CPM –Principles and Applications*, 3<sup>rd</sup> Edition, Affiliated East-West Press Pvt Ltd., New Delhi, 2001.
2. Chris Hendrickson and Tung Au, *Project Management for Construction – Fundamentals Concepts for Owners, Engineers, Architects and Builders*, Prentice Hall, Pittsburgh, 2008.

**II B. Tech. – I Semester**  
**(19BT30102) FLUID MECHANICS**

Int. Marks	Ext. Marks	Total Marks	L	T	P	C
40	60	100	3	-	-	3

**PRE - REQUISITES:** Applied Physics

**COURSE DESCRIPTION:** Fluid properties and fluid statics; Fluid kinematics; Fluid dynamics; Closed conduit flow and flow measurement; Laminar and turbulent flows; Hydraulic similitude and model analysis.

**COURSE OUTCOMES:** On successful completion of this course, the students will be able to:

- CO1 Analyze fluid properties and fluid statics to solve complex problems using appropriate techniques.
- CO2 Analyze fluid flows and forces in fluid kinematics and dynamics using appropriate techniques for solving complex fluid flow problems
- CO3 Analyze conduit flow and its measurement to solve complex fluid flow problems using appropriate tools and techniques following latest developments.
- CO4 Design pipes and piping systems to solve complex conduit flow problems using appropriate techniques.
- CO5 Analyze laminar and turbulent flows to solve complex fluid flow problems using appropriate techniques.
- CO6 Analyze problems associated with hydraulic similitude and model studies to solve complex fluid mechanics problems using appropriate techniques.

**DETAILED SYLLABUS:**

**UNIT – I: FLUID PROPERTIES AND FLUID STATICS (09 Periods)**

Dimensions and units, Physical properties of fluids, Pressure at a point, Pascal's law, Hydrostatic law; Atmospheric, gauge and absolute pressures; Measurement of pressure, Manometers, Hydrostatic forces on submerged plane and curved surfaces – Centre of pressure on plane and curved surfaces, Buoyancy, Centre of Buoyancy, Stability of floating bodies.

**UNIT - II: FLUID KINEMATICS AND DYNAMICS (09 Periods)**

**Fluid Kinematics:** Description of fluid flow, Stream line, Path line and streak line, Stream tube, Classification of flows, Equation of continuity, Stream and velocity potential functions, Flownet and its uses.

**Fluid Dynamics:** Surface and body forces, Euler's Equation, Bernoulli's equation for flow along a stream line and its applications, Vortex flows, Momentum equation and its application, Forces on pipe bend, Moment of momentum equation and its application, Torque on Sprinklers.

**UNIT - III: CLOSED CONDUIT FLOW AND FLOW MEASUREMENT (08 Periods)**

Laws of fluid friction, Major loss, Darcy-Weisbach equation, Minor losses, Pipes in series, Pipes in parallel, Total energy line and hydraulic gradient line, Venturimeter, Orificemeter, Pitot tube, Orifices and mouthpieces, Notches and weirs, Latest flow measuring devices.

**UNIT - IV: LAMINAR AND TURBULENT FLOW****(09 Periods)**

Reynolds's experiment, Characteristics of laminar and turbulent flows, Laminar flow through circular pipes, Hagen Poiseuille equation, Flow between parallel plates, Hydrodynamically smooth and rough boundaries, Moody's chart.

**UNIT - V: HYDRAULIC SIMILITUDE AND MODEL ANALYSIS****(10 Periods)**

Dimensional analysis, Rayleigh's method and Buckingham's pi theorem, Model studies, Similarities - Geometric, kinematic and dynamic similarities; Dimensionless numbers, Model laws, Types of model, Distorted and undistorted model, Resistance on floating and submerged bodies.

**Total Periods: 45**

**Topics for self-study are provided in the lesson plan.**

**TEXT BOOKS:**

1. R. K. Rajput, *A Textbook of Fluid Mechanics*, S. Chand Publishers, 5<sup>th</sup> Edition, 2013.
2. R. K. Bansal, *Fluid Mechanics and Hydraulic Machines*, Laxmi Publishers, 9<sup>th</sup> Edition, 2011.

**REFERENCE BOOKS:**

1. P. N. Modi and S. M. Seth, *Hydraulics and Fluid Mechanics Including Hydraulic Machines*, Standard Book House, 20<sup>th</sup> Edition, 2011.
2. J. F. Douglas, J.M. Gaserek and J.A. Swaffird, *Fluid Mechanics*, 5<sup>th</sup> Edition, Longman, 2010.
3. S. K. Som and G. Biswas, *Introduction to Fluid Machines*, Tata McGraw-Hill Publishers Pvt. Ltd, 2<sup>nd</sup> Edition, 2010.
4. Domkundwar and Domkundwar, *A Textbook of Fluid Mechanics and Hydraulic Machines*, Dhanpat Rai and Co, 6<sup>th</sup> Edition, 2014.

**ADDITIONAL LEARNING RESOURCES:**

1. Streeter, V. L., Wylie, E. B. and Bedford, K. W., *Fluid Mechanics*, McGraw Hill Book Company, New York, 9<sup>th</sup> Edition, Indian Edition, 2017.
2. Frank M White, *Fluid Mechanics*, McGraw Hill, 8<sup>th</sup> Edition, 2016.
3. S. Mukhopadhyay, *Textbook of Fluid Mechanics*, CBS Publishers, 1<sup>st</sup> Edition, 2014.

**II B.Tech. – I Semester**  
**(19BT30103) MECHANICS OF SOLIDS**

Int. Marks	Ext. Marks	Total Marks	L	T	P	C
40	60	100	3	1	-	4

**PRE-REQUISITES:** Course on Engineering Mechanics

**COURSE DESCRIPTION:** Shear force and bending moment; Stresses in beams; Combined direct and bending stresses; Torsion; Springs; Principal stresses and strains; Theories of failures; Columns and struts.

**COURSE OUTCOMES:** On successful completion of this course, the students will be able to:

- CO1. Analyze shear force and bending moment distributions for determinate beams with different loadings to solve complex structural analysis problems besides communicating effectively in graphical form.
- CO2. Design beams considering bending stresses, shear stress, strain energy and theories of failures to solve complex problems ensuring safety besides communicating effectively in graphical form.
- CO3. Analyze direct and bending stresses for columns and chimneys ensuring safety besides communicating effectively in graphical form.
- CO4. Design shafts and springs to solve complex problems ensuring safety.
- CO5. Analyze principal stresses and strains for bars and beams ensuring safety besides communicating effectively in graphical form.
- CO6. Analyze columns and struts for critical loads using appropriate methods ensuring safety.

**DETAILED SYLLABUS:**

**UNIT – I: SHEAR FORCE AND BENDING MOMENT (09 Periods)**

Types of beams, Supports and loads, Concept of shear force and bending moment, SF and BM diagrams - Cantilever, Simply supported, Overhanging beams subjected to point loads, Uniformly distributed load, Uniformly varying load and its combination, Point of contraflexure, Relation between SF and BM, Rate of loading at a section of beam.

**UNIT – II: STRESSES IN BEAMS, DIRECT AND BENDING STRESSES (09 Periods)**

**Stresses in Beams:** Theory of simple bending, Basic bending equation, Neutral axis, Bending stresses, Section modulus of different cross sections, Design of simple beam sections, Strain energy due to bending, Basic shear stress equation, Shear stress distribution for different cross sections, Strain energy due to shear.

**Direct and Bending Stresses:** Stresses under the combined action of direct loading and bending moment, Core of a section, Stresses in chimneys, Conditions for stability, Stresses due to direct loading and bending moment about both axes.

**UNIT – III: TORSION AND SPRINGS (09 Periods)**

**Torsion:** Theory of pure torsion, Torsional equation, Torsional moment of resistance, Polar section modulus, Power transmitted by shafts; combined bending, torsion and end thrust; Design of shafts.

**Springs:** Deflection of close and open coiled helical springs under axial load and axial twist, Springs in series and parallel.

#### **UNIT – IV: PRINCIPAL STRESSES AND STRAINS & THEORIES OF FAILURE**

**(10 Periods)**

**Principal Stresses and Strains:** Stresses on an inclined plane under axial loading, Compound stresses, Normal and tangential stresses on an inclined plane for biaxial stresses, Two perpendicular normal stresses accompanied by a state of simple shear, Mohr's circle of stresses, Triaxial state of stresses, Principal stresses and strains.

**Theories of Failure:** Maximum principal stress theory, Maximum principal strain theory, Maximum shear stress theory, Maximum strain energy theory, Maximum shear strain energy theory.

#### **UNIT – V: COLUMNS AND STRUTS**

**(08 Periods)**

Short, medium and long columns, Axially loaded compression members, Euler's theorem for long columns, Euler's critical load, Equivalent length of a column, Slenderness ratio, Limitations of Euler's theory, Rankine-Gordon formula, Long columns subjected to eccentric loading.

**Total Periods: 45**

**Topics for self-study are provided in the lesson plan.**

#### **TEXT BOOKS:**

1. Punmia, B. C., Ashok Kumar Jain and Arun Kumar Jain, *Mechanics of Materials*, Laxmi Publications Pvt. Ltd., 2001.
2. Bhavikatti, S. S., *Strength of Materials*, Vikas Publishing House, 3<sup>rd</sup> Edition, 2010.

#### **REFERENCES:**

1. Rajput, R. K., *Strength of Materials (Mechanics of Solids)*, S. Chand & Company LTD, 5<sup>th</sup> Edition, 2006.
2. Basu, A. R., *Strength of Materials*, Dhanpat Rai & Co. (P) Ltd., 2<sup>nd</sup> Revised Edition, 2015.
3. Junnarkar, S. B. and Shah, H. J., *Mechanics of Structures – Vol. I (Strength of Materials)*, Charotar Publishing House Pvt. Ltd., 27<sup>th</sup> Revised and Enlarged Edition, 2008.
4. Khurmi, R. S., *Strength of Materials*, S. Chand & Company Ltd., 23<sup>rd</sup> Edition, 2005.

#### **ADDITIONAL LEARNING RESOURCES:**

1. T. D. Gunneswara Rao and Mudimby Andal, *Strength of Materials: Fundamentals and Applications*, Cambridge University Press, 1<sup>st</sup> Edition, 2018.
2. Bansal, R. L., *Strength of Materials*, Laxmi Publications (P) Ltd., 4<sup>th</sup> Revised Edition, 2010.
3. Stephen H. Crandall, Norman C. Dahi, Thomas J. Lardner and Sivakumar M. S., *An Introduction to the Mechanics of Solids*, Tata McGraw-Hill Education Pvt. Ltd., 2<sup>nd</sup> Revised Edition, 2012.
4. S. Timoshenko., *Strength of Materials*, CBS Publishers & Distributors Pvt. Ltd., Revised 3<sup>rd</sup> Edition, Special Indian Edition, 2004.
5. Ryder, G. H., *Strength of Materials*, Macmillan Publishers India Limited, 3<sup>rd</sup> Edition, Special Indian Edition, 2002.
6. Ramamrutham, S. and Narayanan, R., *Theory of Structures*, Dhanpat Rai Publishing Co. Ltd., 9<sup>th</sup> Edition, 2014.



**II B.Tech. – I Semester**  
**(19BT30104) SURVEYING**

Int. Marks	Ext. Marks	Total Marks	L	T	P	C
40	60	100	3	-	-	3

**PRE-REQUISITES:** Courses on Numerical Methods, Probability and Statistics; Applied Physics.

**COURSE DESCRIPTION:** Chain surveying; Compass surveying; Plane tabling; Levelling and contouring; Theodolite surveying; Tacheometric surveying; Computation of areas and volumes; Curves; Electronic distance measurement; Drone surveying.

**COURSE OUTCOMES:** On successful completion of this course, the students will be able to:

- CO1 Analyze chain, compass and plane table surveying techniques for measuring distances, horizontal angles and preparing plans to solve complex surveying problems following ethics and considering society, environment and sustainability besides communicating effectively in graphical form.
- CO2 Analyze leveling and contouring techniques for finding elevations to solve complex surveying problems following ethics and considering society besides communicating effectively in graphical form.
- CO3 Analyze theodolite and tacheometric surveying techniques for finding distances, angles and elevations to solve complex surveying problems following ethics and considering society besides communicating effectively in graphical form.
- CO4 Compute areas and volumes to solve complex surveying problems associated with civil engineering applications using appropriate techniques following ethics and considering society besides communicating effectively in graphical form.
- CO5 Design different types of curves to solve transportation engineering problems using appropriate techniques following ethics and considering society besides communicating effectively in graphical form.
- CO6 Analyze EDM and drone surveying techniques for various applications following ethics and latest developments considering society besides communicating effectively in graphical form.

**DETAILED SYLLABUS:**

**UNIT - I: CHAIN AND COMPASS SURVEYING (10 Periods)**

**Chain Surveying:** Classification of surveying, Objectives, Principles of surveying; Influence of surveying on society, environment and sustainability; Distance measurement, Accuracy and errors, Chain and its types, Optical square, Cross staff, Reconnaissance and site location, Locating ground features by offsets, Field book, Chaining for outline of structures, Methods for overcoming obstacles, Conventional symbols, Plotting chain survey, Computation of areas, Errors in chain surveying and their elimination.

**Compass Surveying:** Types of compass, Bearings, Included angles, Errors and adjustments.

**UNIT - II: PLANE TABLE SURVEYING, LEVELING AND CONTOURING (09 Periods)**

**Plane Table Surveying:** Equipment, Methods of plane tabling, Errors, Two and three point problems.

**Leveling and Contouring:** Types of leveling, Types of leveling instruments, Temporary and permanent adjustments, Height of instrument and rise and fall methods, Plotting

longitudinal sections and cross sections, Effect of curvature and refraction, Characteristics of contours, Uses of contour maps.

### **UNIT - III: THEODOLITE AND TACHEOMETRIC SURVEYING (08 Periods)**

**Theodolite Surveying:** Description of theodolite, Temporary and permanent adjustments of vernier transit, Measurement of horizontal and vertical angles, Heights and distances, Traversing, Closing error and distribution, Gale's traverse table, Omitted measurements.

**Tacheometric Surveying:** Principle of stadia method, Distance and elevation formulae for staff held vertical and normal, Instrumental constants, Anallactic lens, Tangential method.

### **UNIT - IV: COMPUTATION OF AREAS AND VOLUMES, AND CURVES (09 Periods)**

**Computation of Areas:** Areas dividing into number of triangles, By offsets to a base line, By coordinates, Areas from maps.

**Computation of Volumes:** Volume from cross-section, Embankments and cutting for a level section and two level sections with and without transverse slopes, Determination of the capacity of reservoir.

**Curves:** Different types and their characteristics, Setting out, Design of curves by Rankine's and offset methods - Circular, Transition, Combined and vertical curve.

### **UNIT - V: ELECTRONIC DISTANCE MEASUREMENT (EDM) AND DRONE SURVEYING (09 Periods)**

**EDM:** EDM Principle, Modern electronic surveying equipment – Digital levels, Digital theodolites, Total station; Total station – Working principle, Applications: Measurement of distance, Area, Height, Angles, Gradients, Traversing, Contouring, Stake out, Data analysis; Latest developments in EDM survey techniques.

**Drone Surveying:** Working principle, Benefits of drones in surveying, Applications, Interior and exterior drone surveying, Calculation of length, area and stockpile volume.

**Total Periods: 45**

**Topics for self-study are provided in the lesson plan.**

#### **TEXT BOOKS:**

1. B. C. Punmia, Ashok Kumar Jain and Arun Kumar Jain, *Surveying – Vol. I, II and III*, Laxmi Publications (P) Ltd., 17<sup>th</sup> Edition, 2016.
2. R. Subramanian, *Surveying and Leveling*, Oxford University Press, 2<sup>nd</sup> Edition, 2012.

#### **REFERENCE BOOKS:**

1. S. K. Duggal, *Surveying – Vol. I and II*, Tata McGraw-Hill Publishing Co. Ltd., 4<sup>th</sup> Edition, 2013.
2. Arthur R. Benton and Philip J. Taetz, *Elements of Plane Surveying*, McGraw-Hill, 3<sup>rd</sup> Edition, 2010.
3. Arora, K. R., *Surveying – Vol. I and II*, Standard Book House, 14<sup>th</sup> Edition, 2011.
4. T. P. Kanetkar and S. V. Kulakarni, *Surveying and Leveling*, Pune Vidyarthi Griha Prakashan, Pune, 24<sup>th</sup> Edition, 2013.

#### **ADDITIONAL LEARNING RESOURCES:**

1. C. Venkatramaih, *Textbook of Surveying*, Universities Press (India) Limited, Hyderabad, 2<sup>nd</sup> Edition, 2011.
2. Jerry A. Nathanson, Michael T. Lanzafama and Philip Kissam, *Surveying Fundamentals and Practices*, Pearson Publications, 7<sup>th</sup> Edition, 2017.

## II B.Tech. – I Semester

### (19BT3HS31) **SOFT SKILLS LAB**

(Common to CE, ME, EEE, ECE and EIE)

Int. Marks	Ext. Marks	Total Marks	L	T	P	C
50	50	100	-	-	2	1

#### **PRE-REQUISITES: -**

**COURSE DESCRIPTION:** Body Language; Assertiveness; Goal Setting; Thinking Skills; Team Building; Conflict Management; Technical Report Writing; Résumé Writing; Group Discussions; Interview Skills; Interpersonal Skills; Etiquette.

**COURSE OUTCOMES:** After successful completion of the course, students will be able to:

- CO1. Demonstrate knowledge of career skills by examining and applying the styles and strategies of Goal Setting, Thinking Skills, and Etiquettes.
- CO2. Analyze the limitations and possibilities of favourable situations by applying the skills of Body Language and demonstrate through Assertiveness, and Interpersonal Skills.
- CO3. Apply appropriate soft skills by analyzing the problem situations that arise in professional career through demonstrating remedies in Conflict Management.
- CO4. Demonstrate ability to function effectively as an individual and as a member in diverse teams examining and applying soft skills in Interviews, Group Discussion and Team Building.
- CO5. Apply appropriate speaking and writing techniques in preparing documents and to communicate effectively by examining and demonstrating knowledge in Technical Report Writing and Résumé Writing.

**\*First TEN exercises are mandatory among the following:**

#### **List of Exercises:**

##### **1. Body Language**

*Types of Body Language – Parts of Body – Facial Expressions – Eye Contact Insights – Good Posture*

##### **2. Assertiveness**

*Communications Styles – Benefits – Being Unassertive – Role Playing*

##### **3. Goal Setting**

*Seven Steps of Goal Setting – Self Motivation – Personal Goal Setting – Setting Career Goals*

##### **4. Thinking Skills**

*Positive Thinking – Creative Thinking – Lateral Thinking – Logical Thinking – Intuitive Thinking*

##### **5. Team Building**

*Learning Activities – Management Essentials – Team Building Scenarios*

##### **6. Conflict Management**

*Ways of Resolving Conflict – Personality Types and Conflict – Conflict Resolution Process – Team Conflict*

##### **7. Technical Report Writing**

*Objectives – Formats – Writing Styles*

## **8. Résumé Writing**

*Structure and Presentation – Planning – Defining Career Objectives – Projecting One's Strengths and Skills – Cover Letter – Formats and Styles*

## **9. Group Discussions**

*Types of GD – Dos and Don'ts – Dynamics of GD – Intervention – Summarization Techniques*

## **10. Interview Skills**

*Planning – Opening Strategies – Answering Strategies – Tele Conferencing – Video Conferencing*

## **11. Interpersonal Skills**

*Starting a Conversation – Responding to a Conversation – Conversation Examples – Body Language – Role Play*

## **12. Etiquette**

*Basic Social Etiquette – Telephone Etiquette – Dining Etiquette – Conference Etiquette*

## **TEXT BOOKS**

1. Soft Skills Lab Manual, SVEC.

## **REFERENCE BOOKS:**

1. R. C. Sharma & Krishna Mohan, *Business Correspondence and Report Writing*, Tata McGraw-Hill Publishing Company Limited, 3<sup>rd</sup> edition, New Delhi, 2012.

## **SUGGESTED SOFTWARES:**

1. KVAN SOLUTIONS
2. Learning to Speak English 8.1, The Learning Company – 4 CDs.
3. English in Mind, Herbert Puchta and Jeff Stranks with Meredith Levy, Cambridge.
4. Language in Use 1, 2 & 3.
5. Cambridge Advanced Learner's Dictionary - 3rd Edition.
6. Let's Talk English, Regional Institute of English South India.

## **ADDITIONAL LEARNING RESOURCES**

1. <http://www.career.vt.edu/interviewing/TelephoneInterviews.html>
2. [http://job-search-search.com/interviewing/behavioral\\_interviews](http://job-search-search.com/interviewing/behavioral_interviews)
3. <https://goo.gl/laEHOY> (**dealing with complaints**)
4. <http://www.adm.uwaterloo.ca/infocecs/CRC/manual/resumes.html>
5. <https://goo.gl/FEMGXS>

## II B.Tech. – I Semester

### (19BT30131) CIVIL ENGINEERING MATERIALS AND CONSTRUCTION TECHNOLOGY WORKSHOP

Int. Marks	Ext. Marks	Total Marks	L	T	P	C
50	50	100	-	-	2	1

**PRE-REQUISITES:** Course on Civil Engineering Materials and Construction Technology.

**COURSE DESCRIPTION:** Experiments/Exercises on Civil Engineering Materials, Construction Equipment, Masonry, Bar bending, Reinforcement, Painting, House wiring, Shuttering and Scaffolding; Tests on Cement, Fine aggregates, Fresh and hardened concrete; Elasticity; NDT; Mix design - IS method.

**COURSE OUTCOMES:** After completion of this course, a successful student will be able to:

- CO1. Evaluate civil engineering materials using various tools/techniques to solve complex civil engineering material problems by following relevant IS codes and latest developments ensuring cost effectiveness, safety, environment and sustainability.
- CO2. Analyze various construction techniques to solve complex construction technology problems by following current developments ensuring cost effectiveness, safety, environment and sustainability.
- CO3. Design the concrete mix using IS-10262.
- CO4. Perform individually or in a team besides communicating effectively in written, oral and graphical forms on civil engineering materials and construction technology.

#### LIST OF EXPERIMENTS/EXERCISES:

##### Part – I: CIVIL ENGINEERING MATERIALS

##### A. PROPERTIES AND IDENTIFICATION OF CIVIL ENGINEERING MATERIALS

1. Properties and identification of building materials
2. Market survey for building materials

##### B. TESTS ON BRICK

3. Visual inspection test for color, shape and size
4. Soundness of brick
5. Water absorption test of brick
6. Efflorescence test of brick
7. Compressive strength of brick

##### C. TESTS ON CEMENT

8. Fineness of cement by dry sieving
9. Standard consistency of cement
10. Initial and Final setting time of cement
11. Soundness of cement
12. Specific gravity of cement
13. Compressive strength test on cement

#### **D. TESTS ON FINE AGGREGATE**

14. Sieve Analysis of Fine aggregate
15. Specific gravity of Fine aggregate
16. Bulking of Fine aggregate

#### **E. CONCRETE MIX DESIGN – IS Method**

#### **F. TESTS ON FRESH CONCRETE**

17. Slump cone test
18. Compaction factor test
19. Vee-Bee consistometer test

#### **G. TESTS ON HARDENED CONCRETE**

20. Compressive strength test of concrete
21. Split tensile strength test of concrete
22. Flexural strength test of concrete
23. Modulus of elasticity of concrete

#### **H. NON-DESTRUCTIVE TESTS ON HARDENED CONCRETE**

24. Rebound hammer test
25. PUNDIT

### **PART- II: CONSTRUCTION TECHNOLOGY**

#### **A. IDENTIFICATION OF CONSTRUCTION EQUIPMENT**

1. Specifications and identification of construction equipment
2. Market survey for construction equipment

#### **B. MASONRY**

3. Construction of masonry brick wall using English bond
4. Construction of masonry brick wall using Flemish bond

#### **C. BAR BENDING AND REINFORCEMENT**

5. Bar bending of reinforcement skeleton for foundations, columns, beams, slabs, lintels, arches, vaults and stair cases.

#### **D. PAINTING**

6. External wall painting
7. Internal wall painting

#### **F. HOUSE WIRING**

8. 16 A Line
9. 6 A Line

#### **G. SHUTTERING AND SCAFFOLDING**

10. Shuttering for beams and slabs

11. Shuttering for columns and Walls
12. Steel scaffolding
13. Single and double scaffolding

**Note:** A minimum of Fourteen Experiments/Exercises from Part-I and all Experiments/Exercises from Part – II shall be conducted.

**REFERENCE BOOKS/LABORATORY MANUALS:**

1. *Civil Engineering Materials and Construction Technology Workshop Manual (SVEC19 Regulations)*, Department of Civil Engineering, Sree Vidyanikethan Engineering College, Tirupati.
2. S. K. Duggal, *Building Materials*, New Age International Publishers, 4<sup>th</sup> Edition, 2010.
3. A. M. Neville, *Properties of Concrete*, John Wiley and Sons, New Delhi, 5<sup>th</sup> Edition, 2012.

**IS Codes:**

- |                       |   |
|-----------------------|---|
| 1. IS 1077 – 1992     | : Brunt Clay Building Brick.                            |
| 2. IS 4031 - 1988     | : Chemical Analysis and Tests on Cement.                |
| 3. IS 383 - 1970      | : Coarse and Fine Aggregates.                           |
| 4. IS 10264 - 2009    | : Mix Design of Concrete.                               |
| 5. IS 1199 - 1959     | : Methods of Sampling and Analysis of Concrete.         |
| 6. IS 13311- 1992     | : Method of Non-destructive Testing of Concrete.        |
| 7. IS 7293 - 1974     | : Safety Code for Working with Construction Machinery.  |
| 8. IS 2212 - 1991     | : Code of Practice for Brick Work.                      |
| 9. IS 2502 – 1993     | : Code of Practice for Bar Bending And Fixing Of Bars.  |
| 10. IS 2395(1) - 1994 | : Code of Practice for Painting Concrete, Masonry.      |
| 11. IS 732 – 1989     | : Code of Practice for Electrical Wiring Installations. |
| 12. IS 14678 - 1999   | : Guidelines for Falsework for Concrete Structures      |

## II B. Tech. – I Semester

### (19BT30132) **STRENGTH OF MATERIALS LAB**

(Common to CE and ME)

Int. Marks	Ext. Marks	Total Marks	L	T	P	C
50	50	100	-	-	2	1

**PRE-REQUISITES:** Course on Mechanics of Solids/Strength of Materials.

**COURSE DESCRIPTION:** Tests on strength of materials: Tension test; Compression test; Bending test; Shear test; Torsion test; Hardness test; Verification of Maxwell reciprocal theorem.

**COURSE OUTCOMES:** On successful completion of this course, the students will be able to:

- CO1. Evaluate the strength of materials such as steel, timber, metal using appropriate tools/techniques to solve complex problems in accordance with codal provisions ensuring safety.
- CO2. Evaluate the load-deflection behavior for the materials used in beams and springs using appropriate tools/techniques to solve complex problems in accordance with codal provisions ensuring safety.
- CO3. Perform material testing individually or in a team besides communicating effectively in written, oral and graphical forms on strength of materials.

#### **LIST OF EXPERIMENTS:**

1. Tension test on mild steel/HYSD bar
2. Compression test on wood/bricks/mild steel
3. Compression test on coiled spring
4. Tension test on coiled spring
5. Bending test on carriage spring
6. Brinell and Rockwell hardness tests
7. Charpy and Izod impact tests
8. Shear test on mild steel
9. Bending test on simply supported beam
10. Bending test on cantilever beam
11. Bending test on fixed beam
12. Bending test on continuous beam
13. Bending test on overhanging beam
14. Verification of Maxwell's reciprocal theorem
15. Torsion test on mild steel

**Note:** Minimum 12 experiments shall be conducted.

#### **REFERENCE BOOKS/LABORATORY MANUALS:**

1. *Strength of Materials Lab Manual (SVEC19 Regulations)*, Department of Civil Engineering, Sree Vidyanikethan Engineering College, Tirupati.



**II B. Tech. – I Semester**  
**(19BT30133) SURVEYING LAB**

Int. Marks	Ext. Marks	Total Marks	L	T	P	C
50	50	100	-	-	2	1

**PRE-REQUISITES:** Course on Surveying

**COURSE DESCRIPTION:** Exercises on Chain surveying; Compass surveying; Plane table surveying; Auto Levelling; Theodolite surveying; Total station surveying; Drone surveying.

**COURSE OUTCOMES:** On successful completion of this course, the students will be able to:

- CO1. Develop survey plots using chain, compass, plane table, theodolite, total station and drone surveying techniques to solve complex surveying problems following ethics and latest developments considering society, environment and sustainability.
- CO2. Develop contour maps using auto level, total station and drone surveying techniques to solve complex surveying problems following ethics and latest developments considering society, environment and sustainability.
- CO3. Design simple curves to solve transportation engineering problems using appropriate techniques following ethics and considering society.
- CO4. Analyze survey plots for areas using planimeter tool to solve complex surveying problems following ethics and considering society.
- CO5. Perform individually or in a team besides communicating effectively in written, oral and graphical forms on surveying practice.

**LIST OF PRACTICAL EXERCISES:**

**A) CHAIN SURVEY**

- 1. Cross staff survey and plotting
- 2. Chain traversing and plotting

**G) COMPASS SURVEY**

- 3. Determination of area by radiation method and plotting
- 4. Compass traversing and plotting

**H) PLANE TABLE SURVEY**

- 5. Resection – Two point and three point problems

**I) LEVELLING**

- 6. Longitudinal and cross-sectioning of a road profile and plotting
- 7. Contour plan of given area

**J) THEODOLITE SURVEY**

- 8. Measurement of horizontal angles by method of repetition and reiteration
- 9. Trigonometric leveling – Measurement of heights and distances
- 10. Setting out a simple curves by Rankine's method of tangential angles
- 11. Setting out works for buildings and pipe lines (demonstration only)

**K) TOTAL STATION SURVEY**

12. Determination of area using total station
13. Determination of remote height using total station
14. Distance, gradient, and differential height between two inaccessible points using total station
15. Stake-out using total station (demonstration only)
16. Traversing using total station (demonstration only)
17. Contouring using total station (demonstration only)

**G) AREA BY PLANIMETER**

18. Determination of area of irregular figure by using planimeter (demonstration only)

**H) DRONE SURVEY**

19. Determination of length and area using drone survey (demonstration only)
20. Route mapping using drone survey (demonstration only)
21. Contouring using drone survey (demonstration only)

**NOTE:**

Minimum 12 experiments shall be conducted excluding demonstration experiments.

**REFERENCE BOOKS/LABORATORY MANUALS:**

1. *Surveying Laboratory Manual (SVEC19 Regulations)*, Department of Civil Engineering, Sree Vidyanikethan Engineering College, Tirupati.

## II B. Tech.–I Semester

### (19BT315AC) DESIGN THINKING

(Audit Course)

(Common to CE, ME, CSE, CSSE and IT)

Int. Marks	Ext. Marks	Total Marks	L	T	P	C
-	-	-	2	-	-	-

#### **PRE-REQUISITES: -**

#### **COURSE DESCRIPTION:**

Design thinking process, Design thinking phases, empathy tools; Idea generation, visualizing and empathizing; Fidelity for prototypes, prototyping; prototyping for physical products.

**COURSE OUTCOMES:** After successful completion of this course, the students will be able to:

- CO1. Analyze design thinking concepts and principles to perform human centered design process for creative problem solving.
- CO2. Create empathy maps to visualize user attitudes and behavior for gaining insights of customers.
- CO3. Develop innovative products or services for a customer base using ideation techniques.
- CO4. Build prototypes for complex problems using gathered user requirements.
- CO5. Apply design thinking tools techniques to produce good design and relevant products or services for a specific target market.
- CO6. Improve prototype by testing it with a specific set of users for making it sustainable by following ethics.

#### **DETAILED SYLLABUS:**

#### **UNIT - I: INTRODUCTION TO DESIGN THINKING (06 Periods)**

Design Thinking Process: Types of the thinking process, Common methods to change the human thinking process, Design thinking: Definition, Origin of design thinking, Importance of design thinking, Design vs Design thinking, Problem solving, Understanding design thinking and its process model, Design thinking tools.

#### **UNIT - II: EMPATHIZE**

**(06 Periods)**

Design thinking phases, How to empathize, Role of empathy in design thinking, purpose of empathy maps, Things to be done prior to empathy mapping, Activities during and after the session, Understanding empathy tools : Customer Journey Map, Personas.

#### **UNIT - III: IDEATION**

**(06 Periods)**

Challenges in idea generation, need for systematic method to connect to user, Visualize, Empathize, and Ideate method, Importance of visualizing and empathizing before ideating, Applying the method, Ideation Tools: How Might We? (HMW), Story board, Brainstorming.

#### **UNIT - IV: PROTOTYPING**

**(06 Periods)**

What is a prototype? - Prototyping as a mindset, prototype examples, prototyping for products; Why we prototype? Fidelity for prototypes, Process of prototyping- Minimum Viable prototype

#### **UNIT - V: TESTING PROTOTYPES**

**(06 Periods)**

Prototyping for digital products: What's unique for digital, Preparation; Prototyping for physical products: What's unique for physical products, Preparation; Testing prototypes with users.

**Total Periods: 30**

**Topics for Self-Study are provided in Lesson Plan**

#### **TEXTBOOKS:**

1. S.Salivahanan, S.Suresh Kumar, D. Praveen Sam, "Introduction to Design Thinking", Tata Mc Graw Hill, First Edition,2019.
2. Kathryn McElroy, "Prototyping for Designers: Developing the best Digital and Physical Products", O'Reilly, 2017.

#### **REFERENCE BOOKS:**

1. Michael G. Luchs, Scott Swan , Abbie Griffin, "Design Thinking - New Product Essentials from PDMA", Wiley, 2015.
2. Vijay Kumar, "101 Design Methods: A Structured Approach for Driving Innovation in Your Organization", 2012.

#### **ADDITIONAL LEARNING RESOURCES:**

1. <https://www.interaction-design.org/literature/article/5-stages-in-the-design-thinking-process>
2. <https://www.ibm.com/design/thinking/page/toolkit>
3. <https://www.interaction-design.org/literature/article/define-and-frame-your-design-challenge-by-creating-your-point-of-view-and-ask-how-might-we>
4. <https://www.culturepartnership.eu/en/article/ten-tools-for-design-thinking>
5. <https://nptel.ac.in/courses/109/104/109104109/>
6. <https://nptel.ac.in/courses/110106124/>

## II B.Tech.– II Semester

### (19BT40101) ENGINEERING HYDROLOGY

Internal Marks	External Marks	Total Marks	L	T	P	C
40	60	100	3	-	-	3

**PRE-REQUISITES:** Course on Fluid Mechanics

**COURSE DESCRIPTION:** Hydrologic cycle; Applications and history; Weather and seasons in India; Precipitation; Evaporation; Evapotranspiration; Runoff; Stream flow; Groundwater hydrology; Hydrograph analysis; Design flood; Erosion; Reservoir sedimentation.

**COURSE OUTCOMES:** On successful completion of this course, the students will be able to:

- CO1. Analyze hydrologic cycle and precipitation to solve complex hydrology problems using appropriate techniques considering environment and sustainability besides communicating effectively in graphical form.
- CO2. Analyze abstractions from Precipitation and runoff using appropriate tools and techniques for solving complex hydrology problems considering safety, environment and sustainability besides communicating effectively in graphical form.
- CO3. Analyze groundwater hydrology to solve complex problems using appropriate tools and techniques following latest developments and considering safety, environment and sustainability besides communicating effectively in graphical form.
- CO4. Analyze hydrographs using appropriate techniques to solve complex hydrology problems considering environment and sustainability besides communicating effectively in graphical form.
- CO5. Design floods using appropriate techniques to solve flood routing problems following ethics and considering safety, environment and sustainability besides communicating effectively in graphical form.
- CO6. Analyze erosion and reservoir sedimentation to solve complex problems using appropriate techniques and considering safety, environment and sustainability besides communicating effectively in graphical form.

#### **DETAILED SYLLABUS:**

##### **UNIT- I: HYDROLOGY AND PRECIPITATION**

**(09 Periods)**

Scope of hydrology, Hydrologic cycle, Practical applications and historical development; *Precipitation*-Types and forms, Weather and seasons in India, Measurement of rainfall; Recording and non-recording rain gauges, Errors, Analysis and interpretation of rainfall data, Methods of calculation of mean precipitation over an area.

##### **UNIT -II: ABSTRACTIONS FROM PRECIPITATION AND RUNOFF**

**(09 Periods)**

**Abstractions from Precipitation:** Process, Factors, Estimation, Methods of reduction of evaporation, Evapotranspiration - Factors, Measurement, Estimation, Penman Monteith method; Infiltration – Process, Factors, Double ring in filterometer, Infiltration equation and indices, Interception, Horton’s equation and Green Ampt method.

**Runoff:** Components, Factors, Rainfall–runoff relationships, Flow mass curve, Flow duration curve, Mass curve of rainfall, Hyetograph, Double mass curve; Stream flow - Concept, Measurement, Stage, Discharge - Area velocity method, Moving boat method.

**UNIT - III: GROUNDWATER HYDROLOGY (09 Periods)**

Occurrence and movement of groundwater, Darcy's law and its application, Types and properties of aquifers, Conjunctive use and its necessity; Confined and unconfined flow equations; Well hydraulics - Steady and unsteady flow, Well losses, Specific capacity, Pumping and recuperation test; Pollution of groundwater - Sources, Seawater intrusion; Artificial recharge techniques, Groundwater exploration – Methods, Latest developments.

**UNIT - IV: HYDROGRAPH ANALYSIS AND DESIGN FLOOD (10 Periods)**

Components of hydrograph, Unit hydrograph, Derivation, Use and limitation of unit hydrograph, Design flood – Estimation of peak discharge, Methods - Envelope curves, Empirical formulae, Rational method, Unit hydrograph method, S-Curve unit hydrograph, Frequency analysis, Gumbel's and log Pearson Type III methods; Flood routing – Concepts of flow routing, hydraulic and hydrologic routing, Reservoir routing, Channel routing, Muskingum's method.

**UNIT - V: EROSION AND RESERVOIR SEDIMENTATION (08 Periods)**

Erosion process, Estimation of sheet erosion, Channel erosion, Movement of sediment from watersheds, Sediment yield from watersheds, Trap efficiency, Density of sediment deposits, Distribution of sediment in reservoir, Life of a reservoir, Reservoir sedimentation control, Erosion and reservoir sedimentation problems in India.

**Total Periods: 45**

**Topics for self-study are provided in the lesson plan.**

**TEXT BOOKS:**

1. K. Subramanya, *Engineering Hydrology*, Tata McGraw–Hill Education Pvt. Ltd., 4<sup>th</sup> Edition, 2013.
2. P. Jaya Rami Reddy, *A Text Book of Hydrology*, University Science Press, An Imprint of Laxmi Publications Pvt. Ltd., 3<sup>rd</sup> Edition, 2011.

**REFERENCE BOOKS:**

1. H. M. Raghunath, *Ground Water*, Wiley Eastern Ltd., 3<sup>rd</sup> Edition, 2009.
2. David Keith Todd, *Groundwater Hydrology*, Wiley India Pvt. Ltd., 2<sup>nd</sup> Edition, 2010.
3. V. T. Chow., *Hand Book of Applied Hydrology*, Mc Graw–Hill Education Pvt. Ltd., 2<sup>nd</sup> Edition, 2000.
4. C. S. P. Ojah, R. Berndtsson, P. Bhunya, *Engineering Hydrology*, Oxford Higher Education, 5<sup>th</sup> Edition, 2008.

**ADDITIONAL LEARNING RESOURCES**

1. V. P. Singh, *Handbook of Applied Hydrology*, McGraw Hill Education, 2<sup>nd</sup> Edition, 2016.
2. Santosh Kumar Garg, *Water Resources Engineering (Vol. I): Hydrology, Flood Control and Groundwater Engineering*, Khanna Publishers, Delhi, 25<sup>th</sup> Revised Edition, 1973.
3. Murthy, V. V. N. and Madan Kumar Jha, *Land and Water Management Engineering*, Khalyani Publishers, New Delhi, 5<sup>th</sup> Edition, 2013.
4. **Ray K. Linsley, Max Adam Kohler and Joseph L. H.**, *Hydrology for Engineers*, McGraw-Hill Series in Water Resources and Environmental Engineering, McGraw-Hill Education, 3<sup>rd</sup> Edition, SI Metric Edition, 1988.

## II B.Tech. – II Semester

### (19BT40102) ENVIRONMENTAL ENGINEERING

Int. Marks	Ext. Marks	Total Marks	L	T	P	C
40	60	100	3	-	-	3

**PREREQUISITES:** Environmental Science

**COURSE DESCRIPTION:** Water Sources, Quality and Quantity, Intakes; Water Treatment and Distribution Systems; Sewage Characteristics, Collection and Quantity; Sewage Treatment; Sewage Effluent, Sludge Treatment and Disposal.

**COURSE OUTCOMES:** On successful completion of the course, the students will be able to:

- CO1. Analyze water sources, quality and quantity using different tools and techniques for solving water supply problems considering codes of practice, public health and safety, environment and sustainability.
- CO2. Design water treatment and distribution systems using different methods to solve water supply problems by following current developments and considering codes of practice, public health and safety, environment and sustainability besides communicating graphically.
- CO3. Design sewage collection systems for treatment and disposal to solve complex problems considering appropriate methods, code of practices, public health and safety, environment and sustainability.
- CO4. Design sewage treatment and sludge digestion units to solve complex problems by following latest developments and considering code of practices, public health and safety, environment and sustainability besides communicating graphically.
- CO5. Analyze sewage effluent, sludge treatment and disposal, house drainage plumbing systems in buildings using different tools and techniques considering codes of practice, health and safety, environment and sustainability besides communicating graphically.

#### **DETAILED SYLLABUS:**

#### **UNIT - I: WATER SOURCES, QUALITY AND QUANTITY, INTAKES (06 Periods)**

Water Sources – Types, Quality, Quantity, Drinking water quality analysis and standards; Protected water supply – Need, Objectives; Population forecasting – Methods, Design period; Water demand – Types, Per capita demand, Factors affecting, Fluctuations; Intakes – Types, Factors influencing site selection.

#### **UNIT - II: WATER TREATMENT AND SUPPLY (12 Periods)**

**Water Treatment:** Units, Functions, Processes – Aeration, Coagulation, Flocculation, Optimum Coagulant Dosage; Sedimentation – Types, Factors affecting, Design of sedimentation tank; Filtration – Types; Slow and Rapid Gravity Sand Filters - Design, Operation and Maintenance; Disinfection – Methods, Chlorination, Chlorine demand, Break point chlorination; Latest techniques in water treatment.

**Water Supply:** Systems and methods; Distribution systems – Layouts, Design by Hardy Cross and equivalent pipe methods; Water supply arrangements in buildings - Flow meters, Pipe appurtenances, Laying and testing of pipe lines, Leakage prevention, Repair and maintenance.

### **UNIT – III: SEWAGE CHARACTERISTICS, COLLECTION AND QUANTITY**

**(06 Periods)**

Sewage characteristics - Physical, Chemical and Biological; Sewage collection systems – Types, Comparison; Estimation of sanitary sewage and storm water runoff, Hydraulic design of sewers, Sewer appurtenances, BOD Equations and Self purification of streams.

### **UNIT – IV: SEWAGE TREATMENT**

**(12 Periods)**

Layout of sewage treatment plant; Design of primary treatment units - Screen chamber, Grit chamber, Sedimentation tank; Design of secondary treatment units – Attached growth systems - Trickling filters, Rotating Biological Contactors, Bio-towers; Suspended growth systems - Activated Sludge process, Oxidation ditch, Stabilisation pond; Design of sludge digestion tank – Aerobic and anaerobic, Factors influencing the digestion process; Latest techniques in sewage treatment.

### **UNIT – V: SEWAGE EFFLUENT, SLUDGE TREATMENT AND DISPOSAL (09 Periods)**

Disposal of sewage effluent – Dilution, Sewage farming, ISI Effluent disposal standards; Design of septic tank, Soak pit, Dispersion trench; Sludge treatment and disposal, House drainage plumbing systems in buildings.

**Total Periods: 45**

**Topics for self-study are provided in the lesson plan.**

#### **TEXT BOOKS:**

1. G. S. Birdie and J. S. Birdie, *Water Supply and Sanitary Engineering*, Dhanpat Rai and Sons Publishers, 9<sup>th</sup> Edition, 2011.
2. Peavy, H. S, Rowe, D. R., and Tchobanoglous, G., *Environmental Engineering*, McGraw Hill Inc., 1985.

#### **REFERENCE BOOKS:**

1. S. K. Garg, *Environmental Engineering, (Vol. I): Water Supply Engineering*, Khanna Publishers, 20<sup>th</sup> Edition, 2011.
2. S. K. Garg, *Environmental Engineering (Vol. II): Sewage Disposal and Air Pollution Engineering*, Khanna Publishers, 27<sup>th</sup> Edition, 2013.
3. Met Calf and Eddy, *Wastewater Engineering*, TMH Education Pvt. Ltd., 4<sup>th</sup> Edition, 2010.
4. R. Elangovan and M.K Saseetharan, *Unit Operations in Environmental Engineering*, New Age International (P) Limited, 1<sup>st</sup> Edition, 2008.

#### **ADDITIONAL LEARNING RESOURCES:**

1. S. K. Duggal, *Elements of Environmental Engineering*, S. Chand Publishing, 3<sup>rd</sup> Edition, 2013.
2. P. N. Modi, *Water Supply Engineering (Environmental Engineering-I)*, Standard Book House, 6<sup>th</sup> Edition, 2018.
3. P.N. Modi, *Sewage Treatment Disposal and Wastewater Engineering (Environmental Engineering-II)*, Standard Publishers Distributors, 17<sup>th</sup> Edition, 2019.
4. B.C. Punmia, Ashok K. Jain and Arun K. Jain, *Environmental Engineering-II: Wastewater Engineering (Including Air Pollution)*, Laxmi Publications, 2<sup>nd</sup> Edition, 2019.



**II B. Tech. – II Semester**  
**(19BT40103) HYDRAULIC ENGINEERING**

Int. Marks	Ext. Marks	Total Marks	L	T	P	C
40	60	100	3	-	-	3

**PRE-REQUISITES:** Course on Fluid Mechanics

**COURSE DESCRIPTION:** Boundary layer theory; Open channel flow; Impact of jet on vanes; Hydraulic turbines; Pumps.

**COURSE OUTCOMES:** On successful completion of this course, the students will be able to:

- CO1. Analyze boundary layer problems to solve complex hydraulic engineering problems using appropriate techniques besides communicating effectively in graphical form..
- CO2. Design open channels using appropriate tools and techniques for solving complex open channel problems considering safety, environment and sustainability besides communicating effectively in graphical form.
- CO3. Analyze impact of jet on vanes to solve complex fluid flow problems using appropriate techniques considering safety besides communicating effectively in graphical form.
- CO4. Design hydraulic turbines using appropriate techniques to solve hydraulic engineering problems considering safety, environment and sustainability besides communicating effectively in graphical form.
- CO5. Design pumps to solve hydraulic engineering problems using appropriate techniques following latest developments and considering safety, environment and sustainability besides communicating effectively in graphical form.

**DETAILED SYLLABUS:**

**UNIT - I: BOUNDARY LAYER THEORY (10 Periods)**

Boundary layer concepts, Thickness of boundary layer, Characteristics of boundary layer along a thin flat plate, Vonkarmen momentum integral equation, Laminar and turbulent boundary layers, Laminar sub-layer, Separation of boundary layer, Control of boundary layer, Flow around submerged bodies, Drag and lift.

**UNIT – II: OPEN CHANNEL FLOW (09 Periods)**

Types of flows, Types of channels, Velocity distribution, Chezy's, Manning's and Bazin's formulae for uniform flow, Most Economical sections, Critical flow, Specific Energy, Critical depth, Computation of critical depth, Critical, subcritical and supercritical flows, Non-uniform flow, Dynamic equation for gradually varied flow, Types of slopes, Surface profiles, Rapidly varied flow, Hydraulic jump and its applications, Surges.

**UNIT - III: IMPACT OF JET ON VANES (08 Periods)**

Hydrodynamic force of jets on stationary and moving, vertical, inclined and curved vanes, Series of vanes, Jet striking centrally and at tip, Velocity triangles at inlet and outlet, Expressions for work done and efficiency.

**UNIT - IV: HYDRAULIC TURBINES****(10 Periods)**

Layout of a typical hydropower installation, Heads and efficiencies, Classification of turbines, Pelton wheel, Francis turbine, Kaplan turbine, Working and working proportions, Velocity diagrams, Work done and efficiency, Hydraulic design, Runaway speed, Draft tube theory, Function and efficiency, Governing of turbines, Surge tanks, Unit quantities and specific speed, Performance of turbines, Characteristic curves, Cavitation, Causes, Effects, Classification of hydropower plants, Load factor, Utilization factor, Capacity factor, Estimation of hydropower potential.

**UNIT - V: PUMPS****(08 Periods)**

Pumps - Components, Classification; Centrifugal pumps - Classification, Heads, Losses and efficiencies, Limitation of suction lift, Work done, Minimum starting speed, Specific speed; Multistage pumps, Pumps in parallel and series, Performance of pumps, Characteristic curves, Net positive suction head, Priming, Cavitation, Reciprocating pumps - Classification, Work done, Slip, Limitations; Special pumps – Self priming pump, Gear pump, Jet pump, Airlift pump; Latest developments in pumps.

**Total Periods: 45**

***Topics for self-study are provided in the lesson plan.***

**TEXT BOOKS:**

1. R. K. Rajput, *A Textbook of Fluid Mechanics*, S. Chand Publishers, 5<sup>th</sup> Edition, 2013.
2. R. K. Bansal, *Fluid Mechanics and Hydraulic Machines*, Laxmi Publishers, 9<sup>th</sup> Edition, 2011.

**REFERENCE BOOKS:**

1. P. N. Modi and S. M. Seth, *Hydraulics and Fluid Mechanics Including Hydraulic Machines*, Standard Book House, 20<sup>th</sup> Edition, 2011
2. Domkundwar and Domkundwar, *A Textbook of Fluid Mechanics and Hydraulic Machines*, Dhanpat Rai and Co, 6<sup>th</sup> Edition, 2014.
3. V.T .Chow, *Open Channel Flow*, 3<sup>rd</sup> Edition, McGraw–Hill Publishers, 2009.
4. K. Subramanya, *Flow in Open Channels*, 3<sup>rd</sup> Edition, Tata McGraw Hill Publishers, 2010.

**ADDITIONAL LEARNING RESOURCES:**

1. John A. Roberson, John J. Cassidy, and M. Hanif Chaudhry, *Hydraulic Engineering*, 2<sup>nd</sup> Edition, ISBN-13: 978-0471124665, Wiley, 2 Edition, 1998.
2. L. Hamill, *Understanding Hydraulics*, MacMillan Education UK, 3<sup>rd</sup> Edition, 2011.

**II B. Tech. – II Semester**  
**(19BT40104) SOIL MECHANICS**

Int. Marks	Ext. Marks	Total Marks	L	T	P	C
40	60	100	3	-	-	3

**PRE-REQUISITES:**-Courses on Engineering Mechanics, Engineering Geology Lab.

**COURSE DESCRIPTION:** Basic principles of soil mechanics and their application in engineering practice; Index properties; Engineering properties - Permeability and Seepage, Stress distribution and Compaction, Consolidation, Shear strength.

**COURSE OUTCOMES:** On successful completion of this course, the students will be able to:

- CO1. Analyze index properties of soil using appropriate tools and techniques to solve complex soil engineering problems by following the relevant codes of practice and through continuous learning ensuring cost effectiveness besides communicating effectively in graphical form.
- CO2. Analyze permeability and seepage through soils using appropriate tools and techniques to solve complex soil engineering problems by following the relevant codes of practice and ensuring safety, environment and sustainability besides communicating effectively in graphical form.
- CO3. Analyze stress distribution and compaction characteristics of soils using appropriate tools and techniques to solve complex soil engineering problems by following the relevant codes of practice and latest developments ensuring safety, environment and sustainability besides communicating effectively in graphical form.
- CO4. Analyze consolidation characteristics of soils using appropriate tools and techniques to solve complex soil engineering problems by following the relevant codes of practice ensuring safety, environment and sustainability besides communicating effectively in graphical form.
- CO5. Analyze shear strength characteristics of soils using appropriate tools and techniques to solve complex soil engineering problems by following the relevant codes of practice and ensuring safety, environment and sustainability besides communicating effectively in graphical form.

**DETAILED SYLLABUS:**

**UNIT – I: INDEX PROPERTIES OF SOILS (09 Periods)**

Soil formation, Types of soils, Soil structure and clay mineralogy, Adsorbed water, Volume–weight relationships, Three–phase diagram, Moisture content, Specific gravity, In–situ density, Relative density, Grain size analysis – Sieve and hydrometer methods, Plasticity of soils, Consistency limits and indices, I.S. Classification of soils, Sensitivity, Thixotropy, Activity of soil, Field identification of soils, Latest methods.

**UNIT – II: PERMEABILITY AND SEEPAGE THROUGH SOILS (09 Periods)**

**Permeability:** Soil water, Capillary rise, Flow of water through soils, Darcy’s law, Permeability, Factors affecting permeability, Laboratory determination of coefficient of permeability, Permeability of layered systems.

**Seepage through Soils:** Effective stress principle, Effective stress under different loading conditions, Seepage pressure, Quicksand condition, Seepage through soils,

Flownets – Characteristics and uses; Seepage through earth dams with horizontal filter, Critical hydraulic gradient.

### **UNIT – III: STRESS DISTRIBUTION IN SOILS AND COMPACTION (09 Periods)**

**Stress Distribution in Soils:** Boussinesq's theory - Point loads, Line loads, Circular and rectangular loaded areas; Westergaard's theory, Newmark's influence chart, Approximate methods, Contact pressure distribution.

**Compaction:** Mechanism of compaction, Optimum moisture content and maximum dry density, Factors affecting compaction, Effects of compaction on soil properties, Laboratory determination of OMC and MDD, Field compaction – Methods, Latest developments; Compaction control.

### **UNIT – IV: CONSOLIDATION OF SOILS (09 Periods)**

Initial, Primary and secondary consolidation, Spring analogy for primary consolidation, Consolidation test–  $e-p$  and  $e-\log p$  curves; Terzaghi's theory of one dimensional consolidation – Coefficient of consolidation; Pre-consolidation pressure, Secondary consolidation.

### **UNIT – V: SHEAR STRENGTH OF SOILS (09 Periods)**

Mohr–Coulomb failure theories, Types of laboratory shear strength tests, Strength tests based on drainage conditions and their field applicability, Shear strength of cohesionless soils, Critical void ratio, Liquefaction, Shear strength of cohesive soils, Skempton's pore pressure coefficients.

**Total Periods: 45**

**The topics for self-study are provided in the lesson plan.**

#### **TEXT BOOKS:**

1. Gopal Ranjan and A. S. R. Rao, *Basic and Applied Soil Mechanics*, New Age International Pvt. Ltd., 2<sup>nd</sup> Revised Edition, 2014.
2. K. R. Arora, *Soil Mechanics and Foundation Engineering*, Standard Publishers and Distributors, 7<sup>th</sup> Edition, 2014.

#### **REFERENCE BOOKS:**

1. Braja M. Das, *Principles of Geotechnical Engineering*, Cengage Learning India, 7<sup>th</sup> Edition, 2009.
2. B. C. Punmia, Ashok Kumar Jain and Arun Kumar Jain, *Soil Mechanics and Foundation*, Laxmi Publications Pvt. Ltd., 16<sup>th</sup> Edition, 2014.
3. C. Venkatramaiah, *Geotechnical Engineering*, New Age International Publishers, 3<sup>rd</sup> Edition, 2010.
4. Lambe, T. W. and Whitman, R. V., *Soil Mechanics*, John Wiley and Sons, Singapore, 2000.

#### **ADDITIONAL LEARNING RESOURCES:**

1. Richard Handy and Merlin Spangler, *Geotechnical Engineering Soil and Foundation Principles and Practice*, McGraw-Hill Education, 5<sup>th</sup> Edition, 2007.
2. Robert D. Holtz, William D. Kovacs and Thomas C. Sheahan, *An Introduction to Geotechnical Engineering*, Pearson Publication, 2<sup>nd</sup> Edition, 2011.

## II B. Tech. – II Semester

### (19BT40105) STRUCTURAL ANALYSIS

Int. Marks	Ext. Marks	Total Marks	L	T	P	C
40	60	100	3	1	--	4

**PRE-REQUISITES:** Courses on Engineering Mechanics, Mechanics of Solids

**COURSE DESCRIPTION:** Deflection of beams; Energy method; Fixed beams; Clapeyron's theorem; Slope deflection method; Moment distribution method; Kani's method; Moving loads and influence lines; Plastic analysis.

**COURSE OUTCOMES:** On successful completion of this course, the students will be able to:

- CO1. Analyze slope and deflection of beams and pin-jointed trusses to solve complex structural analysis problems using various methods besides communicating effectively in graphical form.
- CO2. Analyze fixed beams using force method to solve complex structural analysis problems besides communicating effectively in graphical form.
- CO3. Analyze continuous beams using various methods to solve complex structural analysis problems besides communicating effectively in graphical form.
- CO4. Analyze determinate beams using the concept of moving loads and influence lines to solve complex structural analysis problems besides communicating effectively in graphical form.
- CO5. Analyze beams using plastic analysis technique to solve complex structural failures ensuring safety besides communicating effectively in graphical form.

#### DETAILED SYLLABUS:

##### UNIT – I: DEFLECTION OF BEAMS

(09 Periods)

Bending into a circular arc, Slope, deflection and radius of curvature; Differential equation for the elastic curve of a beam, Determination of slope and deflection for cantilever and simply supported beams subjected to point loads, U.D.L. and uniformly varying loads; Double integration method, Macaulay's method, Moment area method, Conjugate beam method, Deflections of propped cantilevers for simple loading cases.

##### UNIT – II: ENERGY METHOD AND FIXED BEAMS

(09 Periods)

**Energy Method:** Strain in linear elastic system, Expression of strain energy due to axial load, BM and SF, Castigliano's first theorem, Deflections of simple beams and pin-jointed plane trusses.

**Fixed Beams:** Shear force and bending moment diagrams for fixed end moment due to - Point loads, uniformly distributed load, Uniformly varying load, Couple and combination of loads, Effect of sinking and rotation of support, Deflection of fixed beams.

##### UNIT – III: CLAPEYRON'S THEOREM AND SLOPE DEFLECTION METHOD

(09 Periods)

**Clapeyron's Theorem:** Continuous beams, Clapeyron's theorem of three moments, Analysis of continuous beams with one or both ends fixed, Continuous beams with overhang, Effect of sinking of supports.

**Slope-Deflection Method:** Basic concepts, Slope deflection equation, Application to continuous beams with and without settlement of supports.

**UNIT - IV: MOMENT DISTRIBUTION METHOD AND KANI'S METHOD (09 periods)**

**Moment Distribution Method:** Basic concepts, Stiffness factor, Carryover, Distribution factor, Application to continuous beams with and without settlement of supports.

**Kani's Method:** Basic concepts, Rotation contribution, Rotation factor, Analysis of continuous beams with and without settlement of supports.

**UNIT – V: MOVING LOADS, INFLUENCE LINES AND PLASTIC ANALYSIS**

**(09 Periods)**

**Moving Loads and Influence Lines:** Moving loads; Influence line for support reaction, SF and BM; Load position for maximum SF and for maximum BM at a section; Loading - Point loads, UDL longer than the span, UDL shorter than the span; Equivalent uniformly distributed load.

**Plastic Analysis:** Idealized stress-strain diagram, Moment curvature relationships, Shape factors for various sections, Plastic hinge, Upper bound and lower bound theorems; Collapse loads and plastic moments for simply supported beams, Propped cantilevers, Fixed beams and continuous beams.

**Total Periods: 45**

**Topics for self-study are provided in the lesson plan.**

**TEXT BOOKS:**

1. V. N. Vazirani, M. M. Ratwani and S. K. Duggal, *Analysis of Structures- Vol. I and Vol. II*, Khanna Publications, 17<sup>th</sup> Edition, 2013.
2. R. Vaidyanathan and P. Perumal, *Structural Analysis - Vol. I and II*, Laxmi Publications, 4<sup>th</sup> Edition, 2016.

**REFERENCES:**

1. Bhavikatti, S. S., *Structural Analysis- Vol. I and II*, Vikas Publishing House, 4<sup>th</sup> Edition, 2013.
2. R. S. Khurmi and N. Khurmi., *Theory of Structures*, S. Chand & Company Ltd., 21<sup>th</sup> Edition, 2020.
3. Punmia, B. C., Ashok Kumar Jain and Arun Kumar Jain, *SMTS-II - Theory of Structures*, Laxmi Publications (P) Ltd., 13<sup>th</sup> Edition, 2017.
4. Ramamrutham, S. and Narayanan, R., *Theory of Structures*, Dhanpat Rai Publishing Co. Ltd., 9<sup>th</sup> Edition, 2014.

**ADDITIONAL LEARNING RESOURCES:**

1. Devdas Menon, *Structural Analysis*, Alpha Science International Ltd., 2<sup>nd</sup> Edition, 2017.
2. Hibbeler, R. C., *Structural Analysis*, Pearson Education, 9<sup>th</sup> Edition, 2017.
3. Wang, C. K., *Intermediate Structural Analysis*, McGraw Hill Education, 2017.
4. Alan Williams., *Structural Analysis: In Theory and Practice*, Butterworth-Heinemann, 2009.
5. Pandit, G., Gupta, S. and Gupta, R., *Theory of Structures - Vol. I and II*, Tata Mc-Graw Hill Publishing Co. Ltd., 2<sup>nd</sup> Edition, 1999.
6. Punmia, B. C., Ashok Kumar Jain and Arun Kumar Jain, *Mechanics of Materials*, Laxmi Publications Pvt. Ltd., 2001.

**II B. Tech. – II Semester**  
**(19BT4HS01) BANKING AND INSURANCE**

(Open Elective-2)  
(Common to CE, ME, CSE, CSSE and IT)

Int. Marks	Ext. Marks	Total Marks	L	T	P	C
40	60	100	3	-	-	3

**PRE-REQUISITES: -**

**COURSE DESCRIPTION:** Scope, Objectives and Elements of cost Accounting; Cost Sheet and Tender quotations; Variance Analysis: Material variances, Labor variances; Meaning and Scope, Liquidity, Profitability Ratios: concept of Risk and Return on Investment.

**COURSE OUTCOMES:** *After successful completion of the course, students will be able to:*

- CO1. Demonstrate knowledge in concepts and functions of Banking and Insurance, RBI, bank and customer relationship, types of accounts, types of loans and advances, types of insurance and risk.
- CO2. Develop skills to provide solutions in electronic payment system, business models and insurance claims.

**DETAILED SYLLABUS:**

**UNIT-I: INTRODUCTION TO BANKING (09 Periods)**

Meaning - Importance of banking - Functions of banking - **Reserve Bank of India:** Functions – Role of RBI in sustainable development.

**UNIT-II: BANK-CUSTOMER RELATIONSHIP (09 Periods)**

Debtor-creditor relationship, deposit products or services, payment and collection of cheques. Accounts – Types of accounts, procedure for opening and closing an account - Loans and Advances- Principles of lending and types of loans.

**UNIT-III: ELECTRONIC PAYMENT SYSTEM & BUSINESS MODELS (09 Periods)**

Introduction to Online Banking - types of e-payment system, e-cash, NEFT, RTGS, Credit cards, Debit cards and Electronic Wallet - Business models: B2B, B2C, C2C and B2G.

**UNIT- IV: INTRODUCTION TO RISK AND INSURANCE (09 Periods)**

Concept of risk, risk Vs uncertainty. **Insurance:** Definition, Insurance as risk mitigation mechanism, elements of insurance.

**UNIT- V: INSURANCE OVERVIEW (09 Periods)**

Principles and Functions of Insurance - Types of Insurance - LIC and GIC - IRDA - Insurance Players in India.

**Total Periods: 45**

***Topics for self-study are provided in the lesson plan***

**TEXT BOOKS:**

1. RanganadhaChary,A.V. and Paul, R.R., *Banking and Financial system*, Kalyani Publisher, New Delhi, 3<sup>rd</sup> edition, 2016.
2. Sharma,R.K., Shashi K. Gupta and Jagwant Singh, *Banking and Insurance*, Kalyani Publishers, New Delhi, 17<sup>th</sup> edition, 2014.

**REFERENCES BOOKS:**

1. *Indian Institute of Banking & Finance, Digital Banking*, Taxmann Publications Pvt. Ltd., 2016
2. Jyotsna Sethi and Nishwan Bhatia, *Elements of Banking and Insurance*, PHI Learning Pvt. Ltd., 2<sup>nd</sup> edition, 2012.



## II B. Tech. – II Semester

### (19BT4HS03) COST ACCOUNTING AND FINANCIAL MANAGEMENT

(Open Elective-2)

(Common to CE, ME, CSE, CSSE and IT)

Int. Marks	Ext. Marks	Total Marks	L	T	P	C
40	60	100	3	-	-	3

#### PRE-REQUISITES: -

**COURSE DESCRIPTION:** Scope, Objectives and Elements of cost Accounting; Cost Sheet and Tender quotations; Variance Analysis: Material variances, Labor variances; Meaning and Scope, Liquidity, Profitability Ratios: concept of Risk and Return on Investment.

**COURSE OUTCOMES:** *After successful completion of the course, students will be able to:*

- CO1. Demonstrate knowledge in Costing, Material, Labor, Overheads, Cost control, risk and return, security analysis and portfolio management.
- CO2. Design solutions for effective investment decisions, cost analysis, tenders, quotations, variance analysis, ratio analysis and capital budgeting techniques.

#### DETAILED SYLLABUS:

##### UNIT-I: COST ACCOUNTING (09 Periods)

Meaning of Cost and Cost Accounting, Objectives, Scope, Advantages and disadvantages – Cost Accounting Vs Management Accounting – Elements of Costing – Installation of costing system – Material Control, Labour Control, Overhead Control.

##### UNIT-II: COST SHEET & PREPARATION OF COST SHEET (09 Periods)

Analysis of Cost – Importance of Costing while pricing the products - Preparation of cost sheet, estimate, tender and quotation (Simple problems).

##### UNIT-III: STANDARD COSTING & VARIANCE ANALYSIS (09 Periods)

Introduction to Standard Costing & Variances – Variance Analysis: Material variances, Labour variances (Simple Problems).

##### UNIT-IV: FINANCIAL MANAGEMENT & RATIO ANALYSIS (09 Periods)

Meaning, Objectives - Nature and Scope, Importance of FM – **Ratio Analysis:** Solvency ratios, Liquidity ratios, Profitability ratios, Financial Statement Analysis through ratios (Simple Problems).

##### UNIT-V: INTRODUCTION TO INVESTMENT (09 Periods)

Investment – Meaning and Definition- concept of risk and returns-Investment Alternatives- Capital Budgeting techniques – Security Analysis and Portfolio Management (Basic concepts).

**Total periods: 45**

***Topics for self-study are provided in the lesson plan***

**TEXT BOOKS:**

1. S.P. Jain and K.L. Narang: *Cost Accounting*, Kalyani Publishers, Ludhiana, 10<sup>th</sup> edition, 2016.
2. I.M. Pandey, *Financial Management*, Vikas Publishing House Pvt. Ltd., 14<sup>th</sup> edition, 2016.

**REFERENCE BOOKS:**

1. The Institute of Company Secretaries of India, *Cost and Management Study Material*, New Delhi.
2. CA Saravana Prasath, *Cost Accounting and Financial management*, Wolters Kluwer India Pvt. Ltd., New Delhi, 2018 edition, 2018.

## II B. Tech. - II Semester

### (19BT4HS05) GENDER AND ENVIRONMENT

(Open Elective-2)

(Common to CE, ME, CSE, CSSE and IT)

Int. Marks	Ext. Marks	Total Marks	L	T	P	C
40	60	100	3	-	-	3

#### PRE-REQUISITES: --

**COURSE DESCRIPTION:** Gender and the environment relationship, Gendered Roles in the family & community, Gender and sustainable development, Gender in environmental justice, Gender & environmental security.

**COURSE OUTCOMES:** *After successful completion of the course, students will be able to:*

- CO1. Apply the knowledge of gender & environment connections, key issues and topics within global environmental politics in environmental decision-making.
- CO2. Comprehend the concepts of gender and sustainable development through debates, and policy documents.
- CO3. Analyze the concept of environmental security and justice by identifying the sources of insecurity.

#### DETAILED SYLLABUS:

##### UNIT-I: GENDER AND ENVIRONMENT RELATIONSHIP (09 Periods)

Introduction–Gender and Environment–Development of gender roles–Society, gender & environment – Understanding environmental politics – Gender-environment connections–Eco-feminism – Cultural eco-feminism–Social eco-feminism – Feminist political ecology.

##### UNIT-II: GENDERED ROLES IN THE FAMILY & COMMUNITY (09 Periods)

Organization of the household – Domestic division of labour – Food: growing, harvesting, shopping, preparing, and cooking.

Gender & Power- Planning – Politics – NGO – Gendering of environmental protest – Environmental decision-making.

##### UNIT-III: GENDER AND SUSTAINABLE DEVELOPMENT (09 Periods)

Concept of sustainability & its achievement – Concept of sustainable development – Ecological Modernization – Gender & sustainability debates – Gender & sustainable development debates – Gender in policy documents – Gender, poverty & equity in sustainable development.

##### UNIT-IV: GENDER IN ENVIRONMENTAL JUSTICE (09 Periods)

Normative Concerns ( Fairness, Inequality & Justice) – Making sense of Environmental justice – Ecological debt, Transnational harm, & human rights – Ecological justice – Gender & Environmental Justice – Gender, Vulnerability & risk – Women in

environmental justice movements – Knowledge & participation – Gender, sustainability & justice as guiding concepts.

#### **UNIT-V: GENDER AND ENVIRONMENTAL SECURITY**

**(09 Periods)**

Connections between security & the environment – **Gender, environment & security:** Sustainability as security - poverty & insecurity – Insecurity as injustice – Competing ways of thinking security – Reflecting on sources of insecurity – **Case Study** – Food Security -**Case Study** – The impacts of natural disasters.

**Total Periods: 45**

***Topics for self-study are provided in the lesson plan***

#### **TEXT BOOKS:**

1. Nicole Detraz, *Gender and the Environment*, Polity Press, Cambridge, UK, 2017.
2. Susan Buckingham- Hatfield, *Gender and Environment*, Routledge, London, 2000.

#### **REFERENCE BOOKS:**

1. Promillakapur (ed). (2000). "*Empowering Indian Women*" Publication Division, Government of India, New Delhi.
2. Ronnie Vernooy, (Ed). (2006). "*Social and gender Analysis Natural Resource Management: Learning studies and lessons from Aisa*" Sage, New Delhi.
3. Swarup, Hemlata and Rajput, Pam. (2000). *Gender Dimensions of Environmental and Development Debate: The Indian Experience*" In SturatS.Nagel, (ed). "India"s Development and Public Policy", Ashgate, Burlington.

## II B. Tech. – II Semester

### (19BT4HS07) INDIAN ECONOMY

(Open Elective-2)

(Common to CE, ME, CSE, CSSE and IT)

Int. Marks	Ext. Marks	Total Marks	L	T	P	C
40	60	100	3	-	-	3

#### PRE-REQUISITES: -

**COURSE DESCRIPTION:** Introduction; Time Value of Money; Elementary Economic Analysis; Value Analysis/Value Engineering; Economic Planning.

**COURSE OUTCOMES:** *After successful completion of the course, students will be able to:*

- CO1. Understand the basic concepts of economics, economic analysis, economic planning and strate.
- CO2. Demonstrate knowledge in capital budgeting, evaluation of engineering projects, depreciation policy and familiarize with the concepts of value analysis vs value engineering.

#### DETAILED SYLLABUS:

##### UNIT-I: INTRODUCTION (09 Periods)

Economics - Flow in an Economy, Law of Supply and Demand; Micro and Macro Economics; Relationship between Science, Engineering, Technology and Economic Development; Concept of Engineering Economics-Types of Efficiency, Definition and Scope of Engineering Economics.

##### UNIT-II: ELEMENTARY ECONOMIC ANALYSIS (09 Periods)

Economic Analysis – Meaning, Significance, Simple Economic Analysis; Material Selection for a Product, Substitution of Raw Material; Design Selection for a Product; Material Selection-Process Planning, Process Modification.

##### UNIT-III: ECONOMIC PLANNING (09 Periods)

Introduction - Need For Planning in India, Five year plans(1951-2012), NITI Aayog (from 2014 onwards); Inclusive Growth-Meaning, Significance, Need for inclusive growth in India, Strategy for more inclusive growth, Challenges and Prospects; Employment and Inclusive Growth in India, Role of engineers in sustaining inclusive growth.

##### UNIT-IV: TIME VALUE OF MONEY (12 Periods)

Concepts and Application; Capital Budgeting-Traditional and Modern Methods; Simple and Compound Interest, Cash Flow Diagram, Principle of Economic Equivalence; Evaluation of Engineering Projects – Present Worth Method, Future Worth Method, Annual Worth Method, Internal Rate of Return Method, Cost-benefit Analysis in Public Projects; Depreciation Policy-Depreciation of Capital Assets, Causes of Depreciation, Straight Line Method and Declining Balance Method.

**UNIT-V: VALUE ANALYSIS/VALUE ENGINEERING****(06 Periods)**

Introduction - Value Analysis, Value Engineering, Functions, Aims; Value Analysis vs Value Engineering; Value Engineering Procedure- Advantages, Application Areas.

**Total Periods: 45**

***Topics for self-study are provided in the lesson plan***

**TEXT BOOKS:**

1. Panneer selvam. R., *Engineering Economics*, PHI Learning Private Limited, New Delhi, 2nd edition, 2013.
2. Jain. T. R., V. K. Ohri, O. P. Khanna. *Economics for Engineers*. VK Publication, 1st edition, 2015.

**REFERENCE BOOKS:**

1. DuttRudar and Sundhram K. P. M., *Indian Economy*, S. Chand, New Delhi, 62<sup>nd</sup> revised edition, 2010.
2. Misra. S. K. and V. K. Puri., *Indian Economy: Its Development Experience*, Himalaya Publishing House, Mumbai, 32<sup>nd</sup> edition, 2010.

## II B. Tech. – II Semester

### (19BT4HS09) LIFE SKILLS

(Open Elective-2)

(Common to CE, ME, CSE, CSSE and IT)

Int. Marks	Ext. Marks	Total Marks	L	T	P	C
40	60	100	3	-	-	3

#### PRE-REQUISITES: -

**COURSE DESCRIPTION:** Positive attitude; Self-discovery-Interpersonal relationships; Cross-cultural communication; Core thinking-Problem solving and Decision making; Business presentations and Public speaking.

**COURSE OUTCOMES:** *After successful completion of the course, students will be able to:*

CO1. Gain knowledge in strategies involved in developing positive attitude, process of knowing oneself and managing effective interpersonal relationships.

CO2. Analyse problem solving strategies in Decision Making and SWOT analysis.

CO3. Communicate effectively with Engineering Community and Society by demonstrating presentation skills in professional arena.

#### DETAILED SYLLABUS:

##### UNIT-I: POSITIVE ATTITUDE

(09 Periods)

Introduction, Features of attitudes, Formation of attitudes, Ways of changing attitude in a person, Attitude in a work place, Developing positive attitude, Obstacles in developing positive attitude, Measuring attitude.

##### UNIT-II: SELF DISCOVERY AND INTERPERSONAL RELATIONSHIPS (09 Periods)

Importance of knowing yourself, Process of knowing yourself, SWOT Analysis, Elements of attitude in interpersonal relationships, Methods to deal with different types of interpersonal relationship skills.

##### UNIT-III: CROSS-CULTURAL COMMUNICATION

(09 Periods)

Different Communication Styles, Cultural variables, communication sensitivity and variables of national culture, Individual Cultural Variables, Cross-cultural Communication Strategies, Potential hot spots in cross-cultural communication, Cross-cultural communication – Basic Tips.

##### UNIT- IV: CORE THINKING, PROBLEM SOLVING AND DECISION MAKING

(09 Periods)

Process of developing core thinking skills, Categories of thinking: Critical & Creative, Understanding problem solving, Cause of problems, Stages of problem solving, Methods of problem solving, Types of decision making.

**UNIT-V: BUSINESS PRESENTATIONS AND PUBLIC SPEAKING (09 Periods)**

Business presentations and speeches, structuring the material, Types of delivery, Guidelines for delivery, Effective sales presentation, Controlling nervousness and stage fright.

**Total Periods: 45**

***Topics for self-study are provided in the lesson plan***

**TEXT BOOKS:**

1. Dr. K. Alex (2018) *Soft Skills*, S. Chand and Company Limited, New Delhi.
2. Manmohan Joshi (2017) *Soft Skills*, bookboon.com, Bangalore.

**REFERENCE BOOKS:**

1. Meenakshi Raman and Prakash Singh (2013), *Business Communication*, Oxford University Press, New Delhi.
2. Jeff Butterfield (2011) *Soft Skills for Everyone*, Cengage Learning India Private Limited, Delhi.



## II B. Tech. – II Semester

### (19BT4HS11) PROFESSIONAL ETHICS

(Open Elective-2)

(Common to CE, ME, CSE, CSSE and IT)

Int. Marks	Ext. Marks	Total Marks	L	T	P	C
40	60	100	3	-	-	3

#### PRE-REQUISITES: --

**COURSE DESCRIPTION:** Engineering Ethics; Professional Ideals and Virtues; Engineering as Social Experimentation; Responsibilities and Rights; Global Issues.

**COURSE OUTCOMES:** *After successful completion of the course, students will be able to:*

CO1. Demonstrate knowledge in Engineering Ethics, Responsibilities and Rights.

CO2. Analyze the concepts of Engineering in Social Experimentation and Global Issues.

CO3. Apply the nuances of professional ideals at work place and in social context.

#### DETAILED SYLLABUS:

##### UNIT-I: ENGINEERING ETHICS

(09 Periods)

Scope and aim of engineering ethics, Senses of engineering ethics, Variety of moral issues, Types of inquiry, Moral dilemmas, Moral autonomy-Kohlberg's theory, Gilligan's theory, Consensus and controversy.

##### UNIT-II: PROFESSIONAL IDEALS AND VIRTUES

(08 Periods)

Theories about virtues, Professions, Professionalism, Characteristics, Expectations, Professional responsibility, Integrity, Self-respect, Sense of responsibility, Self-interest, Customs and religion, Self-interest and ethical egoism, Customs and ethical relativism, Religion and divine command ethics, Use of ethical theories, Resolving moral dilemmas and moral leadership.

##### UNIT-III: ENGINEERING AS SOCIAL EXPERIMENTATION

(10 Periods)

Engineering as experimentation, Similarities to standard experiments, Learning from the past and knowledge gained, Engineers as responsible experimenters, Conscientiousness, Moral autonomy and accountability, The challenger case, Codes of ethics and limitations, Industrial standards, Problems with the law of engineering.

##### UNIT-IV: RESPONSIBILITIES AND RIGHTS

(09 Periods)

Collegiality and loyalty, Respect for authority, Collective bargaining, Confidentiality, Conflict of interests, Occupational crime, Rights of engineers, Professional rights, Whistle-blowing, The BART case, Employee rights and discrimination.

##### UNIT-V: GLOBAL ISSUES

(09 Periods)

Multinational corporations, Professional ethics, Environmental ethics, Computer ethics, Engineers as consultants, Witnesses, Advisors and Leaders, Engineers as Managers, Managerial ethics applied to Engineering Profession, moral leadership.

**Total Periods: 45**

***Topics for self-study are provided in the lesson plan***

**TEXT BOOKS:**

1. Mike W. Martin and Roland Schinzinger, *Ethics in Engineering*, Tata McGraw-Hill, 3<sup>rd</sup> edition, 2007.
2. Govindarajan, M., Nata Govindarajan, M., Natarajan, S. and Senthil kumar, V. S., *Engineering Ethics*, Prentice Hall of India, 2004.

**REFERENCE BOOKS:**

1. S. Kannan and K. Srilakshmi, *Human Values and Professional Ethics*, Taxmann Allied Services Pvt Ltd., 2009.
2. Edmund G. Seebauer and Robert L. Barry, *Fundamental of Ethics for Scientists and Engineers*, Oxford University Press, 2001.

**II B. Tech. – II Semester**  
**(19BT4HS13) INDIAN TRADITION AND CULTURE**  
 (Open Elective-2)  
 (Common to CE, ME, CSE, CSSE and IT)

Int. Marks	Ext. Marks	Total Marks	L	T	P	C
40	60	100	3	-	-	3

**PRE-REQUISITES: -**

**COURSE DESCRIPTION:** Basic traits of Indian Culture; Humanistic Reforms under Jainism and Buddhism; Culture in the medieval period; Socio Religious reforms in Indian Culture; Reform movements for harmonious relations.

**COURSE OUTCOMES:** *After successful completion of the course, students will be able to:*

- CO1. Demonstrate the knowledge in Vedic culture, cultural aspects of Buddhism, Jainism and cultural conditions in the medieval period.
- CO2. Understand the impact of socio religious reforms and movements on Indian tradition and culture to improve harmonious relations within society.

**DETAILED SYLLABUS:**

**UNIT-I: BASIC TRAITS OF INDIAN CULTURE (09 Periods)**

Meaning and definition and various interpretations of culture, Culture and its features. The Vedic and Upanishadic culture and society. Human aspirations and values in these societies. Chaturvidha purushardhas, Chaturashrma and Chaturvarna theory.

**UNIT-II: HUMANISTIC REFORMS UNDER JAINISM AND BUDDHISM (09 Periods)**

Salient features of Jainism - contributions of Jainism to Indian culture. Contributions of Aachaarya and Mahaapragya. Buddhism as a humanistic culture. The four noble truths of Buddhism. Contributions of Buddhism to Indian culture.

**UNIT- III: CULTURE IN THE MEDIEVAL PERIOD (09 Periods)**

Unifications of India under Mouryas and Guptas and their cultural achievements. Cultural conditions under satavahanas. Contributions to pallavas and cholas to art and cultural achievements of vijayanagara rulers.

**UNIT-IV: SOCIO RELIGIOUS REFORMS IN INDIAN CULTURE (09 Periods)**

Western impact on India, Introduction of western education, social and cultural awakening and social reform movements of Rajaramohan Roy - Dayanandha Saraswathi- Anne Besant (theosophical society).

**UNIT-V: REFORM MOVEMENTS FOR HARMONIOUS RELATIONS (09 Periods)**

Vivekananda, Eswarchandravidyasagar and Veeresalingam - emancipation of women and struggle against caste. Rise of Indian nationalism. Mahatma Gandhi- Nonviolence and satyagraha and eradication of untouchability.

**Total Periods: 45**

***Topics for self-study are provided in the lesson plan***

**TEXT BOOK(S):**

1. Valluru Prabhakaraiah, *Indian Heritage and Culture*, Neelkamal Publications Pvt. Ltd. Delhi, First Edition, 2015.

**REFERENCE BOOKS:**

1. L. P. Sharma, *History of Ancient India*, Konark Publishers, Pvt. Ltd. New Delhi, 2010.
2. L. P. Sharma, *History of Medieval India*, Konark Publishers, Pvt. Ltd. New Delhi, 2010.
3. L. P. Sharma, *History of Modern India*, Konark Publishers, Pvt. Ltd. New Delhi, 2010.
4. The Cultural Heritage of India Vol-I, II, III, IV, V, The Ramakrishna Mission Institute of Culture, Calcutta.

## II B. Tech. - II Semester

### (19BT40106) **DISASTER MITIGATION AND MANAGEMENT**

(Open Elective-2)

(Common to CE, ME, CSE, CSSE and IT)

Int. Marks	Ext. Marks	Total Marks	L	T	P	C
40	60	100	3	-	-	3

#### **PRE-REQUISITES:** -

**COURSE DESCRIPTION:** Disasters; Earthquakes; Floods; Cyclones; Droughts; Landslides; Disaster management.

**COURSE OUTCOMES:** *After successful completion of the course, students will be able to:*

- CO1. Analyze the vulnerability of an area to natural and man-made disasters/hazards as per the guidelines to solve complex problems using appropriate techniques ensuring safety, environment and sustainability.
- CO2. Propose appropriate mitigation strategies for earthquake and tsunami impacts as per code of practice using suitable techniques ensuring safety, environment and sustainability besides communicating effectively in graphical form.
- CO3. Analyze the causes and impacts of floods, cyclones and droughts using appropriate tools and techniques and suggest mitigation measures ensuring safety, environment and sustainability besides communicating effectively in graphical form.
- CO4. Analyze the causes and impacts of landslides using appropriate tools and techniques and suggest mitigation measures ensuring safety, environment and sustainability.
- CO5. Design disaster management strategies to solve pre, during and post disaster problems using appropriate tools and techniques following the relevant guidelines and latest developments ensuring safety, environment and sustainability besides communicating effectively in graphical form.

#### **DETAILED SYLLABUS:**

##### **UNIT-I: DISASTERS**

**(09 Periods)**

Types of disasters - Natural disasters; Impact of disasters on environment, infrastructure and development; Concepts of hazards and vulnerability analysis, Hazard Assessment, Guidelines for hazard assessment and vulnerability analysis, Basic principles and elements of disaster mitigation.

##### **UNIT-II: EARTHQUAKES**

**(09 Periods)**

Introduction to earthquake, Intensity scale (MSK-64), Seismic zones and activity in India, Action plan for earthquake disaster preparedness, Elements at risk, Recovery and rehabilitation after earthquake, Concepts of Earthquake resistant design and construction of buildings; Tsunami - Onset, Types and causes, Warning, Elements at risk, Typical effects, Specific preparedness and mitigation strategies, Case studies.

**UNIT- III: FLOODS, CYCLONES AND DROUGHTS (11 Periods)**

**Floods and Cyclones:** Onset, Types, Causes, Warnings, Elements at risk, Typical effects, Indian floods and cyclones, Hazard zones, Potential for reducing hazards, Mitigation strategies and community based mitigation, Case studies.

**Droughts:** Onset, Types and warning; Causes, Impact, Early warning and response mechanisms, Mitigation strategies, Droughts in India, Case studies.

**UNIT-IV: LANDSLIDES (08 Periods)**

Onset, Types and warning; Causes, Elements at risk, Indian landslides, Hazards zones, Typical effects, Mitigation strategies and community based mitigation, Case studies.

**UNIT-V: DISASTER MANAGEMENT (08 Periods)**

Disaster management organization and methodology, Disaster management cycle, Disaster management in India – Typical cases and Cost-benefit analysis, Disaster management programs implemented by NGOs and Government of India, Usage of GIS and Remote sensing techniques in disaster management, Leadership and Coordination in Disaster management, Emerging trends in disaster management.

**Total Periods: 45**

***Topics for self-study are provided in the lesson plan***

**TEXT BOOKS:**

1. V. K. Sharma, *Disaster Management*, Medtech Publishing, 2<sup>nd</sup> Edition, 2013.
2. Anand S. Arya, Anup Karanth, and Ankush Agarwal, *Hazards, Disasters and Your Community: A Primer for Parliamentarians*, GOI-UNDP Disaster Risk Management Programme, Government of India, National Disaster Management Division, Ministry of Home Affairs, New Delhi, Version 1.0, 2005.

**REFERENCE BOOKS:**

1. Donald Hyndman and David Hyndman, *Natural Hazards and Disasters*, Cengage Learning, 3<sup>rd</sup> Edition, 2011.
2. *Disaster Management in India*, A Status Report, Ministry of Home Affairs, Govt. of India, May 2011.
3. Rajendra Kumar Bhandari, *Disaster Education and Management: A Joyride for Students, Teachers, and Disaster Managers*, Springer India, 2014.
4. R. B. Singh, *Natural Hazards and Disaster Management*, Rawat Publications, 2009.

**ADDITIONAL LEARNING RESOURCES:**

1. Tushar Bhattacharya, *Disaster Science and Management*, McGraw Hill, 2014.

## II B. Tech. - II Semester

### (19BT40107) SUSTAINABLE ENGINEERING

(Open Elective-2)

(Common to CE, ME, CSE, CSSE and IT)

Int. Marks	Ext. Marks	Total Marks	L	T	P	C
40	60	100	3	-	-	3

#### PRE-REQUISITES: --

**COURSE DESCRIPTION:** Principles of sustainability; Sustainability metrics and assessment tools; Sustainable engineering practices; Sustainable engineering applications; Sustainable urbanization and industrialization.

**COURSE OUTCOMES:** *After successful completion of the course, students will be able to:*

- CO1. Analyze the principles of sustainability to solve complex environmental problems following relevant standards/protocols considering society, health, safety and environment.
- CO2. Analyze sustainability metrics and assessment tools to solve complex environmental problems following relevant standards and emerging trends considering society, health, safety, environment and economics besides communicating effectively in graphical form.
- CO3. Analyze sustainable engineering practices to solve complex environmental problems using appropriate tools and techniques following relevant standards considering society, health, safety, environment, economics and management besides communicating effectively in graphical form.
- CO4. Design sustainable engineering applications to solve complex environmental problems using appropriate tools and techniques following relevant standards considering society, health, safety, environment, economics and management besides communicating effectively in graphical form.
- CO5. Analyze sustainable urbanization and industrialization principles to solve complex environmental problems using appropriate tools and techniques following relevant standards considering society, health, safety, environment, economics and management besides communicating effectively in graphical form.

#### DETAILED SYLLABUS:

##### UNIT-I: PRINCIPLES OF SUSTAINABILITY

(09 Periods)

Emerging challenges, Sustainability and sustainable engineering; Environmental concerns; Social, economic and legal issues; Availability and depletion of natural resources, Disaster resiliency; Multilateral environmental agreements – Basel convention, Clean development mechanism (CDM), Montreal and Kyoto protocols.

##### UNIT II-SUSTAINABILITY METRICS AND ASSESSMENT TOOLS

(09 Periods)

Sustainability indicators, metrics and assessment tools, Material flow analysis and material budget, Carbon footprint analysis, Life cycle assessment, Streamlined life-cycle assessment (SLCA), Economic input output-life cycle analysis, Environmental health risk assessment, Other emerging assessment tools.

**UNIT-III: SUSTAINABLE ENGINEERING PRACTICES (09 Periods)**

Sustainable energy engineering, Sustainable waste management, Green and sustainable buildings and infrastructure, Sustainable civil infrastructure, Sustainable remediation of contaminated sites, Climate geoengineering.

**UNIT-IV: SUSTAINABLE ENGINEERING APPLICATIONS (09 Periods)**

Environmental and chemical engineering projects, Materials engineering projects, Infrastructure engineering projects – Background, Methodology, Goal and Scope, Study area, Technical design, Environmental sustainability, Life cycle assessment, Economic sustainability, Social sustainability, Rating systems – ENVISION, LEED, GRIHA, IGBC; Conclusions.

**UNIT –V: SUSTAINABLE URBANIZATION AND INDUSTRIALIZATION (09 Periods)**

Sustainable urbanization and industrialization, United Nations sustainable development goals – Right to education, Poverty eradication, Social and technological changes; Industrial Processes - Material selection, Energy efficiency, Pollution prevention and control techniques, Industrial Ecology, Industrial symbiosis.

**Total Periods: 45**

***Topics for self-study are provided in the lesson plan***

**TEXT BOOKS:**

1. Reddy, K.R., Cameselle, C., and Adams, J.A., *Sustainable Engineering: Drivers, Metrics, Tools, and Applications*, John Wiley & Sons, Inc., Hoboken, New Jersey, 2019, 544p (ISBN: 978-1-119-49393-8).
2. Allen, D. T. and Shonnard, D. R., *Sustainability Engineering: Concepts, Design and Case Studies*, Pearson Education, 1<sup>st</sup> Edition, 2012.

**REFERENCE BOOKS:**

1. Bradley. A.S; Adebayo, A.O., Maria, P., *Engineering Applications in Sustainable Design and Development*, Cengage Learning, 1<sup>st</sup> Edition, 2016.
2. Purohit, S. S., *Green Technology: An Approach for Sustainable Environment*, Agrobios Publication, 1<sup>st</sup> Edition, 2016.
3. *Energy Conservation Building Code (ECBC) 2007*, Bureau of Energy Efficiency, Govt. of India, New Delhi.
4. Twidell, J. W. and Weir, A. D., *Renewable Energy Resources*, Routledge, Taylor & Francis Group, 3<sup>rd</sup> Edition, 2015.

**ADDITIONAL LEARNING RESOURCES:**

1. Daniel A. Vallero and Chris Brasier, *Sustainable Design: The Science of Sustainability and Green Engineering*, Wiley-Blackwell, 1<sup>st</sup> Edition, 2008.
2. Jorge A. Vanegas, *Sustainable Engineering Practice: An Introduction*, Committee on Sustainability, American Society of Civil Engineers, <https://doi.org/10.1061/9780784407509>, 2004.
3. Mackenthun, K.M., *Basic Concepts in Environmental Management*, CRC Press, Taylor & Francis Group, 1<sup>st</sup> Edition, 1999.
4. *Environment Impact Assessment Guidelines*, Notification of Government of India, 2006.



## II B. Tech. - II Semester

### (19BT40108) CONTRACT LAWS AND REGULATIONS

(Open Elective-2)

(Common to CE, ME, CSE, CSSE and IT)

Int. Marks	Ext. Marks	Total Marks	L	T	P	C
40	60	100	3	-	-	3

#### PRE-REQUISITES: -

**COURSE DESCRIPTION:** Construction contracts; Tenders; Arbitration; Legal requirements; Labour regulations.

**COURSE OUTCOMES:** *After successful completion of the course, students will be able to:*

- CO1. Develop construction contracts to solve complex contract related problems by following laws and regulations considering project schedule, cost, quality and risk.
- CO2. Prepare tenders as per the specifications by following latest developments, laws and regulations to solve complex tender problems considering project schedule, cost, quality and risk.
- CO3. Analyze arbitration problems to address the contract disputes following the laws and regulations in the context of society.
- CO4. Analyze legal issues pertaining to contracts and tenders considering society.
- CO5. Analyze labour regulations to address labour safety issues.

#### DETAILED SYLLABUS:

##### UNIT-I: CONSTRUCTION CONTRACTS

(09 Periods)

Indian contracts act, Elements of contracts, Types of contracts, Features, Suitability, Design of contract documents, International contract document and laws, Standard contract document, Law of torts.

##### UNIT –II: TENDERS

(09 Periods)

Prequalification, Bidding, Accepting; Evaluation of tender from technical, contractual and financial points of view; Two cover system, Preparation of the documentation, Contract formation and interpretation, Potential contractual problems, Price variation clause, Comparison of actions and laws, Subject matter, Violations, Latest developments in tendering.

##### UNIT –III: ARBITRATION

(09 Periods)

Arbitration, Comparison of actions and laws, Agreements, Appointment of arbitrators, Conditions of arbitration, Powers and duties of arbitrator, Rules of evidence, Enforcement of award, Arbitration disputes, Dispute review board.

##### UNIT –IV: LEGAL REQUIREMENTS

(09 Periods)

Legal requirements for planning, Property law, Agency law, Tax laws – Income tax, Sales tax, Excise and custom duties, Local government approval, Statutory regulations, Insurance and bonding, Laws governing purchase and sale, Use of urban and rural land,

Land revenue codes, EMD, Security deposits, Liquidated damages.

**UNIT-V: LABOUR REGULATIONS**

**(09 Periods)**

Social security, Welfare legislation; Laws relating to wages, bonus and industrial disputes; Labour administration, Insurance and safety regulations, Workmen's compensation act, Maternity benefit act, Child labour act, Other labour laws.

**Total Periods: 45**

**Topics for self-study are provided in the lesson plan**

**TEXT BOOKS:**

1. Subba Rao, G.C.V., *Law of Contracts I & II*, S. Gogia & Co., 11<sup>th</sup> Edition, 2011.
2. Jimmie Hinze, *Construction Contracts*, McGraw Hill, 3<sup>rd</sup> Edition, 2011.

**REFERENCES BOOKS:**

1. Kishore Gajaria, *GT Gajaria's Law Relating to Building and Engineering Contracts in India*, Lexis Nexis Butter worths India, 4<sup>th</sup> Edition, 2000.
2. Patil, B. S., *Civil Engineering Contracts and Estimates*, University Press (India) Private Ltd., 4<sup>th</sup> Edition, 2015.
3. Joseph T. Bockrath, *Contracts and the Legal Environment for Engineers and Architects*, McGraw Hill Education, 7<sup>th</sup> Edition, 2010.
4. Akhileshwar Pathak, *Contract Law*, Oxford University Press, 2011.

**ADDITIONAL LEARNING RESOURCES:**

1. P.C. Markanda, Naresh Markanda, Rajesh Markanda, *Building and Engineering Contracts- Law and Practice*, Vol-I and II, 5<sup>th</sup> Edition, LexisNexis Publication.

## II B. Tech. - II Semester

### (19BT40306) GLOBAL STRATEGY AND TECHNOLOGY

(Open Elective-2)

(Common to CE, ME, CSE, CSSE and IT)

Int. Marks	Ext. Marks	Total Marks	L	T	P	C
40	60	100	3	-	-	3

#### PREREQUISITES: -

**COURSE DESCRIPTION:** Introduction to strategic management; Strategic management process; Principles of good strategy; Globalization strategies; Research and Development strategies; Technology Management and Transfer; Elements of Transfer Process; Corporate Governance in the Indian scenario.

**COURSE OUTCOMES:** After successful completion of the course, students will be able to:

- CO1. Demonstrate the knowledge on strategic management, its approaches, and tools through ethical decision making.
- CO2. Analyze the globalization challenges for scrupulous selection of globalization strategies.
- CO3. Apply the R&D strategies and trends to enhance the technological breakthroughs for new products and applications.
- CO4. Demonstrate the knowledge on technology management and transfer that strengthen the economy and accelerate the application of technology and resources.
- CO5. Analyze the challenges of corporate governance in Indian scenario for the effective development of value oriented organizations.

#### DETAILED SYLLABUS:

##### UNIT-I: STRATEGIC MANAGEMENT

(09 Periods)

Introduction, Classes of decisions, Levels of strategy, Core competence, Strategic intent and stretch, Approaches to strategy making, Roles of different strategists, Strategic management-Process, Benefits, Limitations; Ethics in strategic decision making, Principles of good strategy, Strategic Management in India; Common managerial strategy formulation tools.

##### UNIT –II: GLOBALIZATION

(09 Periods)

Definition, Stages, Essential conditions for globalization, Globalization strategies, Competitive advantage of Nations and regions, Factors affecting Globalization, Globalization of Indian business.

##### UNIT –III: RESEARCH & DEVELOPMENT STRATEGIES

(09 Periods)

Concept, Evolution of R and D Management, R and D as a business, R and D as competitive advantage, Elements of R and D strategies, Integration of R and D, Selection and implementation of R and D strategies, R and D trends and challenges.

**UNIT –IV: TECHNOLOGY MANAGEMENT AND TRANSFER (09 Periods)**

**Technology Management:** Introduction, Technology-Definition, Components, Classification Features; Technology Management-Concept, Nature; Drivers of Management of Technology-Significance, Scope, Responding to technology challenges.

**Technology Transfer:** Introduction, Definition, Classification, Significance, Elements of process, Types of Technology Transfer, Package, Modes of Transfer, Routes, Channels and Effectiveness of Technology Transfer.

**UNIT –V: CORPORATE GOVERNANCE: THE INDIAN SCENARIO (09 Periods)**

Emergence of corporate governance in India-Landmarks, Models, Codes and status in India, Role and Responsibilities of Regulators, The Board of Directors; Corporate Governance- Specific issues in India, Family owned Business, Corporate Governance and the Indian ethos.

**Total periods: 45**

***Topics for self-study are provided in the lesson plan***

**TEXT BOOKS:**

1. Francis Cherunilam, *Strategic Management*, Himalaya Publishing House, 3<sup>rd</sup>Edition, 2002.
2. C. S. G. Krishnamacharyulu and Lalitha Ramakrishnan, *Management of Technology*, Himalaya Publishing House, Second Edition, 2012.

**REFERENCE BOOKS:**

1. White and Bruton, *The Management of Technology and Innovation: A Strategic Approach*, Cengage Learning, 1<sup>st</sup>Edition, 2007.
2. S.K.Mandak, *Ethics in Business and Corporate Governance*, TMH, 2<sup>nd</sup>Edition, 2012.

**II B. Tech. - II Semester**  
**(19BT40307) MANAGEMENT SCIENCE**  
 (Open Elective-2)  
 (Common to CE, ME, CSE, CSSE and IT)

Int. Marks	Ext. Marks	Total Marks	L	T	P	C
40	60	100	3	-	-	3

**PRE-REQUISITES: -**

**COURSE DESCRIPTION:** Concepts of Management; Concepts Related to ethics and social responsibility; Human Resource Management; Operations Management; Statistical Process Control; Inventory Management; Marketing; Project Management; Project Crashing.

**COURSE OUTCOMES:** *After successful completion of the course, students will be able to:*

- CO1. Demonstrate the concepts of management, its functions and processes used in optimum resource utilization within the context of ethics and social responsibility.
- CO2. Apply the concepts of HRM for selection and management of human resources.
- CO3. Analyze different operations management problems using quality management tools to produce effective, efficient and adoptable products/services.
- CO4. Identify different marketing strategies to maximize enterprise profitability and customer satisfaction within the realistic constraints.
- CO5. Develop network models in time-cost tradeoff for effective project management.

**DETAILED SYLLABUS:**

**UNIT-I: MANAGERIAL FUNCTION AND PROCESS (10 Periods)**

Concept and foundations of management, Evolution of management thought; Managerial functions – Planning, Organizing, Directing and Controlling; Decision-making; Role of manager, managerial skills; Managing in a global environment, Flexible systems management; Social responsibility and managerial ethics; Process and customer orientation; Managerial processes on direct and indirect value chain.

**UNIT-II: HUMAN RESOURCE MANAGEMENT (08 Periods)**

Human Resource challenges; Human Resource Management functions; Human Resource Planning; Job analysis; Job evaluation, Recruitment and selection; Training and Development; Promotion and transfer; Performance management; Compensation management and benefits; Employee morale and productivity; Human Resource Information System.

**UNIT-III: OPERATIONS MANAGEMENT (10 Periods)**

Fundamentals of Operations Management, Services as a part of operations management; Facilities location and layout; Line balancing; Quality management – Statistical Process Control, Total Quality Management, Six sigma; Role and importance of materials management, Value analysis, Make or Buy decision, Inventory control, Materials Requirement Planning, Enterprise Resource Planning, Supply Chain Management.

**UNIT-IV: MARKETING MANAGEMENT****(08 Periods)**

Concept, evolution and scope; Marketing strategy formulation and components of marketing plan; Segmenting and targeting the market; Positioning and differentiating the market offering, Analyzing competition; Product strategy; Pricing strategies; Designing and managing marketing channels; Integrated marketing communications.

**UNIT –V:PROJECT MANAGEMENT****(09 Periods)**

Project management concepts; Project planning – Work Breakdown Structure, Gantt chart; Project scheduling – Critical Path Method, Program Evaluation and Review Technique, Crashing the project for time-cost trade off; Resource Levelling.

**Total Periods: 45**

***Topics for self-study are provided in the lesson plan***

**TEXT BOOKS:**

1. Martand T. Telsang, *Industrial Engineering and Production Management*, S. Chand, 2<sup>nd</sup> Edition, 2006.
2. Koontz and Weihrich, *Essentials of Management*, TMH, 6<sup>th</sup> Edition, New Delhi, 2007.

**REFERENCE BOOKS:**

1. O.P. Khanna, *Industrial Engineering and Management*, Dhanpat Rai and Sons, 2010.
2. N.D. Vohra, *Quantitative Techniques in Management*, TMH, 2<sup>nd</sup> Edition, New Delhi.
3. L.M. Prasad, *Principles and practice of Management*, S. Chand and Sons, 2006.

**II B. Tech. - II Semester**  
**(19BT40504) CYBER LAWS AND SECURITY**  
(Open Elective-2)  
(Common to CE, ME, CSE, CSSE and IT)

Int. Marks	Ext. Marks	Total Marks	L	T	P	C
40	60	100	3	-	-	3

**PRE-REQUISITES: -**

**COURSE DESCRIPTION:** Evolution of Cyberspace, Jurisdiction in the borderless Cyberspace, E-Contracting, Models of E-Commerce, Modes of Electronic signatures, E-Money, Intellectual Property Rights, Cybercrimes, Privacy and data security.

**COURSE OUTCOMES:** *After successful completion of the course, students will be able to:*

- CO1. Demonstrate knowledge on jurisdiction in cyberspace and the impact of cybercrime to protect privacy on the Internet.
- CO2. Analyze the Indian cyber laws on E-Contracting, E-Commerce, E-signatures and E-money to promote digital law enforcement.
- CO3. Apply the knowledge of digital rights in Indian context to protect intellectual properties in electronic world.
- CO4. Practice ethics and cyber law regulations for leading electronic transactions on the Internet.

**DETAILED SYLLABUS:**

**UNIT-I: EVOLUTION OF CYBERSPACE AND JURISDICTION IN BORDERLESS CYBERSPACE (09 Periods)**

**The Evolution of Cyberspace:** Significance of information technology, Drawbacks in information technology, the digital divide, E-governance, Origin of cyberspace, Legal issues in cyberspace, regulating the Internet.

**Jurisdiction in the Borderless Cyberspace:** Meaning of jurisdiction, Three pre-requisites of jurisdiction, Jurisdictional theories in jurisdiction to prescribe, Tests to determine jurisdiction in Internet law cases, Indian laws to determine personal jurisdiction, Jurisdiction clauses in click wrap agreement.

**UNIT-II: ELECTRONIC CONTRACTING AND ELECTRONIC COMMERCE**

**(09 Periods)**

**Electronic Contracting:** Formation of offline contracts under English common law, Fundamental requirements of an offline contract, Forming an E-contract through website, E-mail contracting, The Indian approach of E-contracts, Contract formation on the Internet and Information Technology Act 2000, B2C E-contracts.

**Electronic Commerce:** Models, Advantages, Restricted activities, Laws, India's information Technology Act 2000, Online customer protection in India (B2B, B2C).

### **UNIT –III: ELECTRONIC SIGNATURES AND ELECTRONIC MONEY (09 Periods)**

**Electronic Signatures:** The role of signatures, Significance of electronic signatures, Modes of electronic signatures, UNCITRAL model law on electronic signatures 2001, Cryptography, Role of certifying authority in PKI, The Indian Information Technology Act and electronic signatures- Electronic signatures, Prescribed authentication mechanisms, Secure electronic record.

**Electronic Money:** E-Money, RBI's guidelines on mobile banking and payments, The current E-payment systems, Earlier E-payment systems, Credit cards, Use of SET in online payment system.

### **UNIT –IV: INTELLECTUAL PROPERTY RIGHTS AND THE INTERNET WORLD (09 Periods)**

Protecting copyright in the E-world, International organizations protecting Intellectual Property, Copyright issues on the Internet, Digital rights management, Patent protection and computer software, India and copyright protection for computer software, Business method patents- Position of Business methods patents in India, Trademark protection on the Internet, Cyber squatting, The Indian trademark law and legal remedies, Hyper linking and framing.

### **UNIT-V: CYBERCRIMES AND PROTECTING PRIVACY ON INTERNET (09 Periods)**

**Cybercrimes:** What is cybercrime, Categories, Different kinds of cybercrime, Cybercrimes and Information Technology Act, 2000 - Territorial scope and applicability, India's national cyber security policy.

**Protecting Privacy on the Internet:** Meaning of privacy, Threat to privacy on the Internet, Use of cookies and web bugs, Terms of use and privacy policy, Government right to interception, Employee privacy rights, Indian legal framework for data protection and privacy, Challenges to right of privacy in India.

**Total Periods: 45**

***Topics for self-study are provided in the lesson plan***

#### **TEXT BOOK(S):**

1. Karnika Seth, *Computers Internet and New technology Laws*, LexisNexis, 2013.

#### **REFERENCE BOOKS:**

1. Sarika Gupta, Gaurav Gupta, *Information Security and Cyber Laws*, Khanna Publishing, 2019.
2. Vivek Sood, *Cyber Law Simplified*, McGraw Hill, 2018.
3. Pavan Duggal, *Textbook on Cyber Law*, Universal LexisNexis, 2019.

#### **ADDITIONAL LEARNING RESOURCES:**

- [https://swayam.gov.in/nd2\\_cec20\\_cs09/preview](https://swayam.gov.in/nd2_cec20_cs09/preview)
- [https://swayam.gov.in/nd2\\_nou19\\_cs08/preview](https://swayam.gov.in/nd2_nou19_cs08/preview)



**II B. Tech. – II Semester**  
**(19BT50208) INTELLECTUAL PROPERTY RIGHTS**

(Open Elective-2)

(Common to CE, ME, CSE, CSSE and IT)

Int. Marks	Ext. Marks	Total Marks	L	T	P	C
40	60	100	3	-	-	3

**PRE-REQUISITES: -**

**COURSE DESCRIPTION:** Introduction to Intellectual Property; Trade Marks; Law of Copy Rights; Law of Patents; Trade Secrets; Unfair Competition; New Development of Intellectual Property.

**COURSE OUTCOMES:** *After successful completion of the course, students will be able to:*

- CO1. Understand the concepts of intellectual property right and new amendments enforced in filling intellectual property right.
- CO2. Understand the processes and principles of trade mark registration and apply them for registering trade mark.
- CO3. Understand the process and principles of copy rights for registration and judicial consequences for violating laws of copyright/patents.
- CO4. Understand the process and principles of trade secrets and judicial consequences for coping trade secrets.

**DETAILED SYLLABUS:**

**UNIT-I: INTRODUCTION TO INTELLECTUAL PROPERTY (10 Periods)**

Introduction and the need for intellectual property rights (IPR); types of intellectual property- Design, Geographical Indication; International organizations, agencies and treaties.

**UNIT –II: TRADEMARKS (08 Periods)**

Introduction to trademark, Purpose and function of trademarks, acquisition of trade mark rights, protectable matter, selecting and evaluating trade mark, trade mark registration processes.

**UNIT- III: LAW OF COPYRIGHTS (09 Periods)**

Fundamental of copy right law, originality of material, rights of reproduction, rights to perform the work publicly, copy right ownership issues, copy right registration, notice of copy right, international copy right law.

**Law of patents:** Foundation of patent law, patent searching process, ownership rights and transfer.

**UNIT –IV: TRADESECRETS (09 Periods)**

Trade secreta law, determination of trade secreta status, liability for misappropriations of trade secrets, protection for submission, trade secreta litigation.

**Unfair competition:** Misappropriation right of publicity, false advertising.

## **UNIT –V: NEW DEVELOPMENT OF INTELLECTUAL PROPERTY (09 Periods)**

New developments in: trade mark law, copy right law, patent law, intellectual property audits. International overview on intellectual property; international - trade mark law, copy right law, international patent law, international development in trade secrets law.

**Total Periods: 45**

**Topics for self-study are provided in the lesson plan**

### **TEXT BOOKS:**

1. Deborah, E. Bouchoux, *Intellectual property: The law of Trademarks, Copyright, Patents, and Trade Secrets*, Cengage learning, 4<sup>th</sup> edition, 2013.
2. PrabuddhaGanguli, *Intellectual property right - Unleashing the knowledge economy*, Tata McGraw Hill Publishing Company Ltd.

### **REFERENCE BOOKS:**

1. Neeraj P and Khusdeep D. *Intellectual Property Rights*. India, IN: PHI learning Private Limited. 1<sup>st</sup> edition 2019.

### **ADDITIONAL LEARNING RESOURCES:**

1. Subramanian, N., & Sundararaman, M. (2018). *Intellectual Property Rights – An Overview*. Retrieved from <http://www.bdu.ac.in/cells/ipr/docs/ipr-eng-ebook.pdf>
2. World Intellectual Property Organisation. (2004). *WIPO Intellectual property Handbook*. Retrieved from [https://www.wipo.int/edocs/pubdocs/en/intproperty/489/wipo\\_pub\\_489.pdf](https://www.wipo.int/edocs/pubdocs/en/intproperty/489/wipo_pub_489.pdf)

**II B. Tech. - II Semester**  
**(19BT50409) GREEN TECHNOLOGIES**  
 (Open Elective-2)  
 (Common to CE, ME, CSE, CSSE and IT)

Int. Marks	Ext. Marks	Total Marks	L	T	P	C
40	60	100	3	-	-	3

**PRE-REQUISITES: -**

**COURSE DESCRIPTION:** Principles of green engineering; Green communications; Green energy; Green computing; Green construction; Green manufacturing.

**COURSE OUTCOMES:** *After successful completion of the course, students will be able to:*

- CO1. Analyze energy efficient communication systems such as Telecommunication systems, ICT, Wireless networks and cellular networks by understanding the principles of green communications.
- CO2. Understand the impact of conventional energy sources on environment and realize the significance and principles of green energy sources for sustainability.
- CO3. Understand the environmental impacts of IT and approaches for Green IT.
- CO4. Analyze concepts of sustainable green construction using appropriate tools and techniques following latest developments and considering safety and environment besides communicating effectively in graphical form.
- CO5. Demonstrate the environmental impact of traditional manufacturing and explore the need for green manufacturing process promoting sustainability.

**DETAILED SYLLABUS:**

**UNIT-I: PRINCIPLES OF GREEN ENGINEERING AND GREEN COMMUNICATIONS**  
**(09 Periods)**

**Principles of Green Engineering:** Introduction, Definition of green engineering, Principles of green engineering

**Green Communications:** Introduction, Origin of Green Communications, Energy Efficiency in Telecommunication systems, Telecommunication system model and energy Efficiency, Energy saving concepts, Quantifying energy efficiency in ICT, Energy efficiency metrics of green wireless networks, Embodied energy of communication devices- Introduction, The extended energy model, Embodied/Operating Energy of a BS in Cellular network- A Case study; Energy efficient standards for wireline communications.

**UNIT –II: GREEN ENERGY** **(09 Periods)**

Introduction, green energy systems - composition, adverse impacts, Green energy and sustainability, the target and solution. Diversification and localization of energy systems, green energy and sustainable development. Energy sources and their availability. Green energy sources - solar energy, wind energy, geothermal energy, ocean energy, biomass and biogas.

**UNIT –III: GREEN IT****(09 Periods)**

Introduction, Awareness to Implementation: Green IT Trends, Green Engineering, Greening by IT: Using RFID for Environmental Sustainability, Smart Grids, Smart Buildings and Homes, Green Supply Chain and Logistics, Enterprise-Wide Environmental Sustainability, A Seven-Step Approach to Creating Green IT Strategy: Balancing the Costs and Benefits of Going Green, Research and Development Directions.

**UNIT –IV: GREEN CONSTRUCTION****(09 Periods)**

**Green Building:** Concept, Necessity, Characteristics, Benefits, Requisites for green building construction, Sustainability, Concept of REDUCE, REUSE, RECYCLE, RETHINK, REPLENISH AND REFUSE (6 R's), Sustainable construction focus point – Site selection, Planning, Water, Energy, Material, Indoor air quality, Construction procedures, case studies of residential and commercial green buildings.

**Vastu:** Concept, History, scientific approach, elements of vastu for selecting a plot.

**Indian Green Building Council:** Introduction to IGBC green homes, Benefits of IGBC, IGBC green home rating system, Introduction to USGBC, LEED rating system, Procedure to get IGBC certification, GRIHA Rating.

**UNIT –V: GREEN MANUFACTURING****(09 Periods)**

Green Manufacturing - Introduction, Background and Definition; Impact of traditional manufacturing in environmental ecology, Need for green manufacturing, Motivation and barriers to green manufacturing, Advantages and Limitations of green manufacturing, Green manufacturing strategies, Green manufacturing and sustainability, Green manufacturing through clean energy supply, Green packaging and Supply chain.

**Total Periods: 45**

**Topics for self-study are provided in the lesson plan**

**TEXT BOOKS:**

1. Konstantinos Samdanis, Peter Rost, Andreas Maeder, Michela Meo, Christos Verikoukis, *Green Communications: Principles, Concepts and Practice*, John Wiley & Sons, 2015.
2. G.D. Rai, *Non-conventional Energy Sources*, Khanna Publishers, Delhi, 5th Edition, 2011.
3. San Murugesan, G.R. Gangadharan, *Harnessing Green IT – Principles and Practices*, John Wiley & Sons Ltd., 2008.
4. Tom Woolley, Sam Kimmins, Paul Harrison and Rob Harrison, *Green Building Handbook*, Volume 1, E & FN Spon, an imprint of Thomson Science & Professional.
5. J Paulo Davim, *Green Manufacturing: Processes and Systems*, Springer, 2012.
6. David A Dornfeld, *Green Manufacturing: Fundamentals and Applications*, Springer, 2013.

**REFERENCE BOOKS:**

1. Soli J. Arceivala, *Green Technologies for a better future*, McGraw Hill Education (India) Pvt. Ltd, 2014.
2. Marty Poniatowski, *Foundation of Green Information Technology*, Prentice Hall, 2009.
3. Athanasios V Alavanidis, Thomais Vlachogianni, *Green Chemistry and Green Engineering*, Synchrone Themata, 2012.

## II B.Tech. - II Semester

### (19BT40131) ENVIRONMENTAL ENGINEERING LAB

Int. Marks	Ext. Marks	Total Marks	L	T	P	C
50	50	100	-	-	2	1

**PREREQUISITES:** Course on Environmental Engineering.

**COURSE DESCRIPTION:** Experimental analysis of physical, chemical and biological parameters of water and wastewater; Analysis of an ambient air quality.

**COURSE OUTCOMES:** On successful completion of this course, the students will be able to:

- CO1. Evaluate water using various tools and techniques to solve complex water problems by following the standard procedures/norms and latest developments ensuring safety, environment and sustainability.
- CO2. Evaluate wastewater using various tools and techniques to solve complex wastewater problems by following the standard procedures/norms and latest developments ensuring safety, environment and sustainability.
- CO3. Perform individually or in a team besides communicating effectively in written, oral and graphical forms on water supply and wastewater engineering.

#### LIST OF EXPERIMENTS:

1. Determination of pH, electrical conductivity and TDS of a given water sample
2. Determination of alkalinity and acidity of a given water sample
3. Determination of total solids, volatile and fixed solids of a given water sample
4. Determination of chlorides of a given water sample
5. Determination of iron and fluoride content of a given water sample
6. Determination of residual chlorine of a given chlorinated water sample
7. Determination of turbidity and optimum coagulant dose of a given water sample
8. Determination of dissolved oxygen and BOD of a given wastewater sample
9. Determination of COD of a given wastewater sample
10. Determination of nitrate nitrogen as  $\text{NO}_3$  of a given wastewater sample
11. Determination of sulphates as  $\text{SO}_4$  of a given wastewater sample
12. Determination of phosphates as  $\text{PO}_4$  of a given wastewater sample
13. Determination of color of a given water or wastewater sample
14. Bacterial examination of a given water or wastewater sample (not for examination)
15. Determination of air pollutants of an ambient air (not for examination)

#### REFERENCE BOOKS/LABORATORY MANUALS:

1. *Environmental Engineering Lab Manual (SVEC19 Regulations)*, Department of Civil Engineering, Sree Vidyanikethan Engineering College, Tirupati.

## II B.Tech. – II Semester

### (19BT40132) FLUID MECHANICS AND HYDRAULIC MACHINERY LAB

(Common to CE and ME)

Int. Marks	Ext. Marks	Total Marks	L	T	P	C
50	50	100	-	-	2	1

**PRE-REQUISITES:** Courses on Fluid Mechanics, Hydraulic Engineering/Fluid Mechanics and Hydraulic Machinery.

**COURSE DESCRIPTION:** Calibration of flow meters; Verification of Bernoulli's equation; Performance of turbines and pumps; Losses through pipes.

**COURSE OUTCOMES:** On successful completion of this course, the students will able to:

- CO1 Evaluate fluid flow characteristics using appropriate tools and techniques to solve fluid mechanics problems by following latest developments and ensuring safety.
- CO2 Evaluate the performance and behaviour of hydraulic machinery using appropriate tools and techniques to solve hydraulic machinery problems by following latest developments and ensuring safety.
- CO3 Perform individually or in a team besides communicating effectively in written, oral and graphical forms on fluid mechanics and hydraulic machinery.

#### LIST OF EXPERIMENTS:

1. Calibration of venturimeter
2. Calibration of orificemeter
3. Determination of coefficient of discharge for a small orifice by a constant head
4. Determination of coefficient of velocity for small orifice by variable head method
5. Calibration of rectangular notch
6. Determination of loss of head due to sudden contraction
7. Determination of coefficient of friction for pipes
8. Verification of Bernoulli's equation
9. Study of impact of jet on vanes
10. Study of hydraulic jump
11. Performance test on Pelton wheel
12. Performance test on Francis turbine
13. Performance test on Kaplan turbine
14. Performance test on single stage centrifugal pump
15. Performance test on multi stage centrifugal pump
16. Performance test on reciprocating pump

#### REFERENCE BOOKS/LABORATORY MANUALS:

1. *Fluid Mechanics and Hydraulic Machinery Laboratory Manual (SVEC19 Regulations)*, Department of Civil Engineering, Sree Vidyanikethan Engineering College, Tirupati.

## II B.Tech.–II Semester

### (19BT40133) GEOTECHNICAL ENGINEERING LAB

Int. Marks	Ext. Marks	Total Marks	L	T	P	C
50	50	100	-	-	2	1

**PREREQUISITES:** Course on Soil Mechanics.

**COURSE DESCRIPTION:** Experiments on the determination of index properties and engineering properties of soil.

**COURSE OUTCOMES:** On successful completion of this course, the students will be able to:

- CO1 Evaluate index properties of soil using appropriate tools and techniques to solve complex soil engineering problems by following the relevant codes of practice and through continuous learning ensuring safety and environment.
- CO2 Evaluate engineering properties of soil using appropriate tools and techniques to solve complex soil engineering problems by following the relevant codes of practice and through continuous learning ensuring safety and environment.
- CO3 Perform individually or in a team besides continuous learning and communicating effectively in written, oral and graphical forms on civil engineering materials and construction technology.

#### LIST OF EXPERIMENTS:

##### A. INDEX PROPERTIES OF SOIL

1. Determination of water content
2. Determination of specific gravity
3. Grain size analysis – sieve analysis and hydrometer analysis
4. Tests for Atterberg's limits
  - (a) Determination of liquid limit – Casagrande's method and cone penetrometer method
  - (b) Determination of plastic limit
  - (c) Determination of shrinkage limit
5. Determination of field density – core cutter method and sand replacement method
6. Relative density test

##### B. ENGINEERING PROPERTIES OF SOIL

1. Standard Proctor's compaction test
2. CBR Test
3. Permeability of soil – constant head test and variable head test
4. Consolidation test
5. Direct shear test
6. Unconfined compression test
7. Tri-axial compression test
8. Vane shear test

#### REFERENCE BOOKS/LABORATORY MANUALS:

1. *Geotechnical Engineering Laboratory Manual (SVEC19 Regulations)*, Department of Civil Engineering, Sree Vidyanikethan Engineering College, Tirupati.

## II B.Tech. II Semester

### (19BT3MC01) ENVIRONMENTAL SCIENCE (Mandatory Course) (Common to CE, ME, CSE, CSSE and IT)

Int. Marks	Ext. Marks	Total Marks	L	T	P	C
40	-	40	2	-	-	-

#### PRE-REQUISITES: -

**COURSE DESCRIPTION:** Natural resources; Ecosystems; Biodiversity; Environment pollution and control; Social issues and environment; Human population and environment.

**COURSE OUTCOMES:** On successful completion of this course, the students will be able to:

- CO1 Analyze natural resources to solve complex environmental problems and natural resource management considering society, environment and sustainability.
- CO2 Analyze ecosystems and biodiversity to solve complex environmental problems by following environmental ethics considering society, environment and sustainability besides communicating effectively in graphical form.
- CO3 Analyze various types of pollution and their control measures to solve environmental problems through appropriate tools and techniques following latest developments considering society, ethics, environment and sustainability.
- CO4 Analyze social issues and its impact on environment, environmental acts to solve complex environmental problems considering society, environment and sustainability besides communicating effectively in graphical form.
- CO5 Analyze human population and its impact on environment to solve complex environmental problems through team work and using appropriate tools and techniques considering ethics, society, environment and sustainability.

#### DETAILED SYLLABUS:

##### UNIT - I: NATURAL RESOURCES

(07 Periods)

Multidisciplinary nature of environment; Natural Resources: Renewable and non-renewable resources; Forest, Water, Mineral, Food and Energy resources -Causes, Effects, Remedies, Case studies; Role of an individual in conservation of natural resource and equitable use of resources for sustainable lifestyles.

##### UNIT - II: ECOSYSTEMS AND BIODIVERSITY

(07 Periods)

**Ecosystems:** Concept of an ecosystem, Structure and function of an ecosystem - Producers, Consumers, Decomposers; Food chains, Food webs, Ecological pyramids - Types; Characteristic features, Structure and functions of forest ecosystem, Desert ecosystem, Aquatic ecosystem.

**Biodiversity:** Concept and value of biodiversity, Role of biodiversity in addressing new millennium challenges, Hot spots of biodiversity, Threats to biodiversity, Man-wild life conflicts, Endemic, Endangered and extinct species of India, Conservation of biodiversity - In-situ and ex-situ.



**UNIT - III: ENVIRONMENTAL POLLUTION AND CONTROL (06 Periods)**

Causes, Adverse effects and control measures of pollution - Air pollution, Water pollution, Soil pollution, Noise pollution, Thermal pollution, Nuclear pollution, Solid waste management - Urban waste, industrial waste; Latest developments in pollution control, Hazards and disaster management - Floods, Earthquakes, Tsunamis, Case studies.

**UNIT - IV: SOCIAL ISSUES AND THE ENVIRONMENT (06 Periods)**

Sustainable development, Urban problems related to energy, Environmental ethics - Issues, Solutions; Global warming, Acid rain, Ozone layer depletion, Nuclear accidents and case studies, Wasteland reclamation, Consumerism and waste products, Concept of green technologies, Environment justice: National Green Tribunal and its importance; Environment protection act, Air act, Water act, Wildlife protection act, Forest conservation act, Issues involved in enforcement of environmental legislation, Public environmental awareness.

**UNIT - V: HUMAN POPULATION AND THE ENVIRONMENT (04 Periods)**

Population growth, Population characteristics and variation among nations, Population explosion, Family welfare programme, Environment and human health, Human rights, Value education, HIV/AIDS, Women and child welfare, Role of information technology in environment and human health; Case studies - Field Work/Assignment/Seminar on Environmental assets - Water bodies/Forest/Grassland/Hill/Mountain.

**Total Periods: 30**

***Topics for self-study are provided in the lesson plan.***

**TEXT BOOKS:**

1. Anubha Kaushik and C. P. Kaushik, *Perspectives in Environmental Studies*, New Age International (P) Ltd. Publications, 6<sup>th</sup> Edition, 2018.
2. Erach Barucha, *Environmental Studies*, Orient Blackswan, 2<sup>nd</sup> Edition, 2013.

**REFERENCE BOOKS:**

1. Cunningham W.P. and Cunningham M.A., *Principles of Environmental Science*, Tata McGraw-Hill Publishing Company, New Delhi, 8<sup>th</sup> Edition, 2016.
2. Benny Joseph, *Environmental Studies*, Tata McGraw-Hill, 2<sup>nd</sup> Edition, 2009.
3. M. Anji Reddy, *Text Book of Environmental Sciences and Technology*, BS Publications, 2014
4. R. Rajagopalan, *Environmental Studies*, Oxford University Press, 2<sup>nd</sup> Edition, 2011.

**ADDITIONAL LEARNING RESOURCES:**

1. B. S. Chauhan, *Environmental Studies*, University Science Press, 2<sup>nd</sup> Edition, 2018.
2. Botkin and Keller, *Environmental Science: Earth as a Living Planet*, John Wiley & Sons, 8<sup>th</sup> International Student Edition, 2011.

### III B.Tech. – I Semester

#### (19BT50101) IRRIGATION ENGINEERING AND HYDRAULIC STRUCTURES

Int. Marks	Ext. Marks	Total Marks	L	T	P	C
40	60	100	3	-	-	3

**PRE-REQUISITES:** Courses on Fluid Mechanics, Hydraulic Engineering, Engineering Hydrology.

**COURSE DESCRIPTION:** Irrigation and water requirement of crops; Diversion head works; Gravity dams, earth dams and spillways; Canal structures; Cross drainage works.

**COURSE OUTCOMES:** On successful completion of this course, the students will be able to:

- CO1. Analyze irrigation methods for estimating adequate irrigation water requirements considering latest developments, relevant standards, public health and safety, environment, sustainability, irrigation management besides communicating effectively in graphical form.
- CO2. Analyze diversion head works for solving complex irrigation engineering problems using different techniques considering relevant codes of practice, safety, environment and sustainability besides communicating effectively in graphical form.
- CO3. Design gravity dams, earth dams and spillways for solving complex irrigation engineering problems using different tools and techniques considering codes of practice, safety, environment and sustainability besides communicating effectively in graphical form.
- CO4. Design canal structures for solving complex irrigation engineering problems using different tools and techniques considering codes of practice, safety, environment and sustainability besides communicating effectively in graphical form.
- CO5. Design cross drainage works for solving complex irrigation engineering problems using different tools and techniques considering codes of practice, safety, environment and sustainability besides communicating effectively in graphical form.

#### **DETAILED SYLLABUS:**

#### **UNIT - I: IRRIGATION AND WATER REQUIREMENT OF CROPS (09 Periods)**

Necessity and importance, Advantages and disadvantages, Types of irrigation, Application of irrigation water, Sources of water for irrigation, Standards for irrigation water, Soil–water–plant relationship, Vertical distribution of soil moisture, Soil moisture constants, Consumptive use, Duty–delta relationship, Factors affecting duty, Crops and crop seasons in India, Irrigation efficiency, Frequency of irrigation, Irrigation scheduling – Water distribution – Participatory irrigation management with a case study, Latest developments in irrigation.

#### **UNIT - II: DIVERSION HEAD WORKS (09 Periods)**

Types of diversion head works – Weirs, Barrages; Layout of diversion works, Causes and failure of hydraulic structures on permeable foundations, Bligh’s creep theory, Khosla’s theory -Design principles of various weirs.

#### **UNIT - III: GRAVITY DAMS, EARTH DAMS AND SPILLWAYS (10 Periods)**

**Gravity Dams:** Forces acting on gravity dam, Causes of failure of gravity dams, Elementary profile and practical profile of gravity dam, Limiting height of a low gravity dam, Stability analysis of gravity dam.

**Earth Dams:** Types, Causes of failure, Criteria for safe design, Seepage through earth dam, Measures of seepage control, Stability analysis.

**Spillways:** Types, Design of Ogee spillway, Energy dissipaters –Types, Advantages and disadvantages.

#### **UNIT - IV: CANAL STRUCTURES**

**(09 Periods)**

Types of canals, Alignment of canals, Lining of Canals, Design of canals, Kennedy's and Lacey's theory, Falls – Types, Design of Sarda type fall; Canal regulation works, Canal outlets – Types.

#### **UNIT - V: CROSS DRAINAGE WORKS**

**(08 Periods)**

Types, Design and selection of site for aqueducts, super passages, level crossing; River training works.

**Total Periods: 45**

**Topics for self-study are provided in the lesson plan.**

#### **TEXT BOOKS:**

1. Garg, S. K., *Irrigation Engineering and Hydraulic Structures*, Khanna Publishers, 36<sup>th</sup> Edition, 2019.
2. Modi, P. N., *Irrigation Water Resources and Water Power Engineering*, Standard Book House, 22<sup>nd</sup> Edition, 2019.

#### **REFERENCE BOOKS:**

1. Arora, K. R., *Irrigation, Water Power and Water Resources Engineering*, Standard Publishers Distributors, 4<sup>th</sup> Revised Edition, 2014.
2. Asawa, G. L., *Irrigation and Water Resources Engineering*, New Age International Limited, 2012.
3. Sharma, R. K. and Sharma, T. K., *Irrigation Engineering*, S. Chand Publishers, 3<sup>rd</sup> Edition, 2007.
4. Punmia, B. C. and Lal, P. B. B., *Irrigation and Water Power Engineering*, Laxmi Publications, 16<sup>th</sup> Edition, 2011.

#### **ADDITIONAL LEARNING RESOURCES:**

1. Chen Sheng-Hong, *Hydraulic Structures*, Springer-Verlag Berlin Heidelberg, 1<sup>st</sup> Edition, 2015.
2. Jose LiriaMontanes, *Hydraulic Canals: Design, Construction, Regulation and Maintenance*, CRC Press, 1<sup>st</sup> Edition, 2005.

#### **CODES:**

- IS: 6512 – 1984 : Criteria for Design of Solid Gravity Dams, 1<sup>st</sup> Edition, 1998.  
IS: 9429 – 1999 : Drainage System for Earth and Rockfill Dams - Code of Practice, 1<sup>st</sup> Edition, 1999.  
IS: 4839 – 1992 : Maintenance of Canals-Code of Practice, 1<sup>st</sup> Edition, 1992.

### III B. Tech. – I Semester

#### (19BT50102) FOUNDATION ENGINEERING

Int. Marks	Ext. Marks	Total Marks	L	T	P	C
40	60	100	3	-	-	3

**PRE-REQUISITES:** Course on Soil Mechanics.

**COURSE DESCRIPTION:** Soil exploration; Lateral earth pressure; Earth retaining structures; Stability of earth slopes; Bearing capacity of shallow foundations; Pile foundations, Caissons and well foundations.

**COURSE OUTCOMES:** On successful completion of this course, the students will be able to:

- CO1 Analyze soil exploration to solve complex foundation engineering problems using appropriate tools and techniques by following the relevant codes of practice and through continuous learning ensuring safety, environment and cost effectiveness besides communicating effectively in graphical form.
- CO2 Analyze lateral earth pressures to solve complex foundation engineering problems using appropriate techniques ensuring safety and environment besides communicating effectively in graphical form.
- CO3 Analyze stability of earth slopes to solve complex slope stability problems using appropriate techniques by following the relevant codes of practice and ensuring safety, environment and sustainability besides communicating effectively in graphical form.
- CO4 Design shallow foundations to solve complex foundation engineering problems using appropriate techniques by following the relevant codes of practice and ensuring safety and environment besides communicating effectively in graphical form.
- CO5 Design pile foundations; well and caisson foundations to solve complex foundation engineering problems using appropriate techniques by following the relevant codes of practice and ensuring safety and environment besides communicating effectively in graphical form.

#### **DETAILED SYLLABUS:**

##### **UNIT – I: SOIL EXPLORATION**

**(09 Periods)**

Need, Planning, Methods of soil exploration - Geophysical methods, Open excavation methods, Boring and sampling methods; Types of soil samples, Field tests - SPT, CPT, Plate load test, In-situ vane shear test; Borehole logging, Soil investigation report, Latest methods.

##### **UNIT – II: LATERAL EARTH PRESSURE**

**(09 Periods)**

Types of earth pressures, Plastic equilibrium in soils, Rankine's theory - Earth pressures in cohesionless and cohesive soils; Coulomb's wedge theory, Earth pressure on retaining walls of simple configurations, Graphical methods (Rebhann and Culmann), Types of earth retaining structures, Stability considerations of gravity and cantilever retaining walls.

**UNIT – III: STABILITY OF EARTH SLOPES****(08 Periods)**

Infinite and finite earth slopes, Types of failures, Factor of safety of infinite slopes, Stability analysis of finite slopes, Bishop's simplified method, Taylor's stability number, Stability of slopes of earth dams under different conditions, Improving stability of slopes.

**UNIT - IV: BEARING CAPACITY OF SHALLOW FOUNDATIONS (10 Periods)**

Types and choice of foundation, Depth of foundation, Types of shear failure, Safe bearing capacity, Bearing capacity theories- Terzaghi, Meyerhof, Skempton and IS methods; Effect of groundwater table on bearing capacity, Bearing capacity from SPT and CPT, Allowable bearing pressure, Safe bearing capacity and settlement from plate load test, Allowable settlements of structures, Settlement analysis.

**UNIT – V: PILE FOUNDATIONS, CAISSONS AND WELL FOUNDATIONS****(09 Periods)**

**Pile Foundations:** Types of pile foundations, Factors influencing the selection of pile, Load carrying capacity of piles in granular and cohesive soils, Static and dynamic pile formulae, Pile load test, Negative skin friction, Load carrying capacity of pile groups in sands and clays, Settlement of pile groups, Design of piles and pile groups.

**Caissons and Well Foundations:** Types of caissons, Bearing capacity, Construction, Advantages and disadvantages, Well foundations - Shapes, Components, Sinking, Tilts and shifts.

**Total Periods: 45**

**Topics for self-study are provided in the lesson plan.**

**TEXT BOOKS**

1. Venkataramaiah, C., *Geotechnical Engineering*, New Age International Publishers, 3<sup>rd</sup> Edition, 2010.
2. Arora, K. R., *Soil Mechanics and Foundation Engineering*, Standard Publishers and Distributors, 7<sup>th</sup> Edition, 2010.

**REFERENCE BOOKS:**

1. Punmia, B. C., Ashok Kumar Jain and Arun Kumar Jain, *Soil Mechanics and Foundations*, Laxmi Publications, 16<sup>th</sup> Edition, 2005.
2. Gopal Ranjan and Rao, A. S. R., *Basic and Applied Soil Mechanics*, New Age International, 2<sup>nd</sup> Revised Edition, 2010.
3. Braja M. Das, *Principles of Foundation Engineering*, Cengage Learning India, 6<sup>th</sup> Edition, 2007.
4. Bowles, J. E., *Foundation Analysis and Design*, McGraw-Hill Publishing Company, 5<sup>th</sup> Edition, 2001.

**ADDITIONAL LEARNING RESOURCES:**

1. Das, B. M., *Advanced Soil Mechanics*, CRC Press, 5<sup>th</sup> Edition, 2019.
2. Murthy, V. N. S., *Advanced Foundation Engineering*, CBS Publisher, 4<sup>th</sup> Edition, 2017.

**IS CODES:**

- IS 6403 - 1981 : Determination of Bearing Capacity for Shallow Foundations.  
IS 2911 – 2010 : Design and Construction of Pile Foundations.  
IS 1080 – 1985 : Design and Construction of Shallow Foundations in Soils (other than Raft, Ring and Shell).  
IS 1892 – 1979 : Subsurface Investigation of Shallow Foundations in Soils.

### III B.Tech. – I Semester

#### (19BT50103) REINFORCED CEMENT CONCRETE STRUCTURES

Int. Marks	Ext. Marks	Total Marks	L	T	P	C
40	60	100	3	-	-	3

**PRE-REQUISITES:** Courses on Civil Engineering Materials and Construction Technology, Engineering Mechanics, Mechanics of Solids, Structural Analysis.

**COURSE DESCRIPTION:** Design of reinforced cement concrete structural elements: Beams (Working stress and limit state methods); Shear, torsion and bond; Slabs; Columns; Shallow footings and stair cases.

**COURSE OUTCOMES:** On successful completion of this course, the students will be able to:

- CO1. Design of beams for flexure to solve complex problems related to reinforced cement concrete structures using appropriate methods and relevant codes of practice ensuring safety and serviceability besides communicating effectively through schematic detailing.
- CO2. Design of beams for shear, torsion and bond to solve complex problems associated with reinforced cement concrete structures using appropriate methods and relevant codes of practice ensuring safety and serviceability besides communicating effectively through schematic detailing.
- CO3. Design of slabs to solve complex problems related to reinforced cement concrete structures using appropriate methods and relevant codes of practice ensuring safety and serviceability besides communicating effectively through schematic detailing.
- CO4. Design of columns to solve complex problems associated with reinforced cement concrete structures using appropriate methods and relevant codes of practice ensuring safety, stability and serviceability besides communicating effectively through schematic detailing.
- CO5. Design footings and staircases to solve complex problems associated with reinforced cement concrete structures using appropriate methods and relevant codes of practice ensuring safety and serviceability besides communicating effectively through schematic detailing.

#### DETAILED SYLLABUS:

##### UNIT - I: BEAMS

(09 Periods)

**Beams (Working Stress Method):** Methods of design used in reinforced concrete structural elements, Behaviour of RCC beam in bending, Concept of working stress method, Design of singly reinforced rectangular beams for bending.

**Beams (Limit State Method):** Concept of limit state method, Design of simply supported singly and doubly reinforced beams for flexure - Rectangular, T and L beams.

##### UNIT - II: SHEAR, TORSION AND BOND

(08 Periods)

Limit state analysis and design of section for shear and torsion; Concept of bond, anchorage and development length; I.S. code provisions, Design of simply supported and continuous beams - Detailing; Limit state design for serviceability for deflection, cracking and codal provision.

##### UNIT - III: SLABS (LIMIT STATE METHOD)

(08 Periods)

Limit state design of one way, two way and continuous slabs.

**UNIT - IV: COLUMNS (LIMIT STATE METHOD) (08 Periods)**

Design of axially and eccentrically loaded short and long column.

**UNIT - V: SHALLOW FOOTINGS AND STAIRCASES (LIMIT STATE METHOD) (12 Periods)**

**Shallow Footings:** Design of isolated square and rectangular footings for axially and eccentrically loaded columns, Design of combined footing.

**Staircases:** Types of staircases, Stairs spanning longitudinally and transversally.

**Total Periods: 45**

**Topics for self-study are provided in the lesson plan.**

**TEXT BOOKS**

1. Unnikrishna Pillai, S., and Devdas Menon, *Reinforced Concrete Design*, Tata Mc. Graw Hill, 3<sup>rd</sup> Edition, 2016.
2. Krishna Raju, N. and Pranesh, R. N., *Reinforced Concrete Design*, CBS Publishers Distributors, 4<sup>th</sup> Edition, 2016.

**REFERENCE BOOKS**

1. Varghese, P. C., *Limit State Designed of Reinforced Concrete*, Prentice Hall of India, 2<sup>nd</sup> Edition, 2010.
2. Punmia, B. C., Ashok Kumar Jain and Arun Kumar Jain, *Reinforced Concrete Structures – Vol. I*, Laxmi Publications Pvt. Ltd., 7<sup>th</sup> Edition, 2013.
3. Roy, S. K., and Sinha, N., *Fundamentals of Reinforced Concrete*, S. Chand & Company Ltd., 6<sup>th</sup> Edition, 2013.
4. Gambhir, M. L., *Fundamentals of Reinforced Concrete Design*, Printice Hall of India Pvt. Ltd., 2010.

**ADDITIONAL LEARNING RESOURCES**

1. Park and Paulay, *Reinforced Concrete Structures*, Willey Publishers, 1975.
2. Arthus Nilson, H., David Darwin, and Chorles W., *Design of Concrete Structures*, Tata Mc. Graw-Hill, 3<sup>rd</sup> Edition, 2005.
3. Karve, S. R., and Shah, V. R., *Limit State Theory and Design of Reinforced Concrete*, Standard Publishers, Pune, 3<sup>rd</sup> Edition, 1994.

**CODES**

IS 456 - 2000	: Plan and Reinforced Concrete – Code of Practice
SP 16 – 1980	: Design Aids for Reinforced Concrete to IS 456
SP 34 - 1987	: Concrete Reinforcement and Detailing
IS 875 – 2015	: Design Loads and Structures
IS 1893 – 2016	: Earthquake Resistant Design
IS 4326 – 2013	: Earthquake Resistant Design and Construction of Buildings
IS 13920 – 2016	: Ductile Detailing of Framed Structures

### III B. Tech. – I Semester

#### (19BT50104) TRANSPORTATION ENGINEERING

Int. Marks	Ext. Marks	Total Marks	L	T	P	C
40	60	100	3	-	-	3

**PRE-REQUISITES:** Courses on Surveying, Soil Mechanics

**COURSE DESCRIPTION:** Highway development and planning; Highway geometric design; Pavement materials; Pavement design; Traffic engineering; Railway engineering; Airport engineering.

**COURSE OUTCOMES:** On successful completion of this course, the students will be able to:

- CO1 Analyze highway development, planning and highway materials to solve complex highway engineering problems using appropriate tools and techniques following relevant codes considering society and environment besides communicating effectively in graphical form.
- CO2 Design highway, railway and airport geometric features to solve complex highway, railway and airport engineering problems using appropriate techniques and following relevant codes considering society, environment and sustainability besides communicating effectively in graphical form.
- CO3 Design bituminous mix and pavements to solve complex highway and airport engineering problems using appropriate techniques and following relevant codes considering society, environment and sustainability besides communicating effectively in graphical form.
- CO4 Analyze traffic to solve complex traffic engineering problems using appropriate tools and techniques following relevant codes and latest developments considering society and environment.
- CO5 Analyze various components of railways to solve complex railway engineering problems using appropriate tools and techniques considering society and environment besides communicating effectively in graphical form.
- CO6 Analyze various components of airports to solve complex airport engineering problems using appropriate tools and techniques considering society and environment besides communicating effectively in graphical form.

#### DETAILED SYLLABUS:

##### UNIT – I: HIGHWAY DEVELOPMENT, PLANNING AND GEOMETRIC DESIGN

(9 Periods)

**Highway Development and Planning:** Highway development in India; Highway planning; Different road development plans; Classification of roads; Road network patterns; Highway alignment – Factors affecting, Engineering surveys, Drawings and reports.

**Highway Geometric Design:** Importance of geometric design; Design controls and criteria; Highway cross sectional elements; Sight distance elements; Stopping sight distance; Overtaking sight distances; Design of horizontal curves - Design of super elevation and extra widening, Design of transition curves; Design of vertical alignment - Gradients, Vertical curves.

##### UNIT-II: PAVEMENT MATERIALS AND DESIGN

(9 Periods)

**Pavement Materials:** Soil, Aggregates and bitumen –Desirable properties; Tests on subgrade soil – CBR test, Tests on aggregate and bitumen; Aggregate-bitumen mixes – Desirable properties, Mix design by Marshal method; Cement and cement concrete.

**Pavement Design:** Pavements – Types, Functions and components; Design factors; Flexible pavement design methods – G.I., CBR and Triaxial method; Design of rigid



pavements - Critical load positions, Westergaard's stress analysis, Computing radius of relative stiffness and equivalent radius of resisting section, Stresses in rigid pavements, Design of expansion and contraction joints in CC pavements, Design of dowel bars and tie bars.

### **UNIT-III: TRAFFIC ENGINEERING**

**(9 Periods)**

Significance and scope, Characteristics of road users – Driver and vehicle characteristics, Skid resistance and braking efficiency; Components of traffic engineering - Road, Traffic and land use characteristics, Basic characteristics of traffic – Human characteristics, Vehicle characteristics; Traffic parameters and their studies - Volume, Speed and density, Latest trends; Highway Capacity – Definition, Importance and Factors; Levels of service – Concept, Types; Concept of service volume.

### **UNIT-IV: RAILWAY ENGINEERING**

**(9 Periods)**

General features of Indian railways; Route alignment surveys - Conventional and modern methods; Gauges – types, choice of gauge; Permanent way – cross section, components, functions, coning of wheels; Rails - Rail joints, Welding of rails, Creep of rails, Sleeping – Types, Density and spacing, Adzing of sleepers; Ballast; Subgrade; Track geometric design; Points and crossings; Signaling and interlocking.

### **UNIT-V: AIRPORT ENGINEERING**

**(9 Periods)**

Aircraft characteristics; Planning and site selection; Obstruction criteria; Air traffic control; Runways - orientation, length, design of geometric features, capacity, configuration; Taxiways -design of geometric features, fillets, high speed exit taxiway; Taxiways -design of geometric features, fillets, high speed exit taxiway; Terminal building - functional areas and facilities; Visual aids; Airport drainage.

**Total Periods: 45**

**Topics for self-study are provided in the lesson plan.**

### **TEXT BOOKS**

1. Khanna, K. and Justo, C. E. G., *Highway Engineering*, Nem Chand & Bros, Roorkee, 10<sup>th</sup> Edition, 2014.
2. Chandra, S. and Agarwal, M.M., *Railway Engineering*, Oxford University Press, New Delhi, India, 2<sup>nd</sup> Edition, 2013.
3. Khanna, S. K. and Arora, M. G., *Airport Planning and Design*, Nem Chand & Bros., 6<sup>th</sup> Edition, 2017.

### **REFERENCE BOOKS:**

1. Kadiyali, L. R., *Traffic Engineering and Transport Planning*, Khanna Technical Publications, Delhi, 7<sup>th</sup> Edition, 2010.
2. JotinKhisty, C. and Kent Lall, B., *Transportation Engineering – An Introduction*, Prentice Hall of India Pvt. Ltd., 3<sup>rd</sup> Edition, 2016.
3. Partha Chakroborthy and Animesh Das, *Principles of Transportation Engineering*, Prentice Hall of India Pvt. Ltd, 2<sup>nd</sup> Edition, 2017.
4. Papacostas, C. S. and Prevedouros, P. D., *Transportation Engineering and Planning*, Prentice Hall of India Pvt. Ltd., 3<sup>rd</sup> Edition, 2009.
5. Mannering, F. L. And Washburn, S. S., *Principles of Highway Engineering and Traffic Analysis*, John Wiley & Sons, Inc., 5<sup>th</sup> Edition, 2013.

### **ADDITIONAL LEARNING RESOURCES:**

1. Yang H. Huang, *Pavement Analysis and Design*, Pearson Prentice Hall, 2<sup>nd</sup> Edition, 2004.
2. Nicholas J. Garber and Lester A. Hoel, *Traffic and Highway Engineering*, Cengage Learning, 4<sup>th</sup> Edition, 2009.

**CODES:**

IRC 37 – 2018

: Design of Flexible Pavements

IRC 58 – 2015

: Design of Rigid Pavements

IS2386-1963 (Part I to IV)

: Methods of Test for Aggregates for Concrete

**III B. Tech. – I Semester**  
**(19BT4BS01) MATERIAL SCIENCE**  
**(Open Elective-1)**  
**(Common to CE, ME, CSE, CSSE and IT)**

Int. Marks	Ext. Marks	Total Marks	L	T	P	C
40	60	100	3	-	-	3

**PRE-REQUISITES: -**

**COURSE DESCRIPTION:** Introduction to Material Science and Engineering; Composite Materials; Smart Materials; Nano and Biomimetic Materials; Emerging Materials.

**COURSE OUTCOMES:** On successful completion of this course, the students will be able to:

- CO1. Attain the basic knowledge on composites, smart materials, biomimetic materials and nano materials.
- CO2. Demonstrate essential information about structure and properties of various composites used in various engineering applications.
- CO3. Understand the basic properties of electro-rheostatic, magneto-rheostatic and shape memory alloys used in device applications.
- CO4. Accomplish the basic knowledge in nano materials to familiarize various nano structured device applications.
- CO5. Outline the processing and properties of functionally graded materials and identify its applications in various fields.

**DETAILED SYLLABUS:**

**UNIT- I: INTRODUCTION TO MATERIAL SCIENCE AND ENGINEERING**

**(8 Periods)**

Introduction - historical perspective - material science and engineering, classification of materials (metals, ceramics, polymers and composites) and advanced materials and their applications (biomaterials, smart materials and nano materials), modern materials needs. Processing, properties and applications of metals, polymers and ceramics (Qualitative).

**UNIT- II: COMPOSITE MATERIALS**

**(10 Periods)**

Composite Materials - Classification, Laminated composites and Reinforced composite materials – Classification, structure and properties of sandwich composites – applications (commercial Aircraft, Marine Grade Sandwich, Automobile Grade Sandwich and Wind Turbine Blades), properties and applications of Nano composites - Advantages and Limitations of composites.

**UNIT-III: SMART MATERIALS**

**(7 Periods)**

Classification of smart materials -Magneto-rheostatic (MR) and Electro-rheostatic (ER) materials - Shape Memory Alloys (SMA)- characteristics, Shape memory effect applications in different fields, advances in smart materials.

**UNIT – IV: NANO AND BIOMIMETIC MATERIALS (10 Periods)**

**Nanomaterials:** Introduction, Low dimensional structures and energy quantization. Fabrication of nano materials - Lithographic technique using photons, metallic, semiconducting and magnetic properties of nano materials and applications (renewable energy and nano electro-mechanical systems (NEMS)).

**Biomimetic materials** – Introduction- classification and their applications (Lotus effect, Dolphin sound wave technology and viper as a model in defence)

**UNIT- V: EMERGING MATERIALS (10 Periods)**

Functionally graded materials (FGM) - Types, processing, properties and potential applications, functionally graded fibre cement – structural material, Functionally Graded Nanoelectronic, Optoelectronic and Thermoelectric Materials (Qualitative) and its applications.

**Total Periods: 45**

**Topics for Self Study are provided in the Lesson Plan**

**TEXT BOOKS:**

1. William D Callister, David G Rethwisch, *Materials Science and Engineering*, Wiley, 9<sup>th</sup> edition, 2014.
2. K M Gupta, *Engineering Materials – Research, Applications and Advances*, CRC press (Taylor & Francis group), 2015.

**REFERENCE BOOKS:**

1. Sulabha K Kulkarni, *Nanotechnology: Principles and practices*, Springer, 9<sup>th</sup> edition, 2014.
2. Charles P. Poole and Frank J. Owens, *Introduction to Nanotechnology*, Wiley-Interscience, May 2003.
3. Sulabha K Kulkarni, *Nanotechnology: Principles and Practices*, Springer, 3<sup>rd</sup> edition, 2014.

### III B. Tech. - I Semester

#### (19BT4HS02) BUSINESS COMMUNICATION AND CAREER SKILLS

(Open Elective-1)

(Common to CE, ME, CSE, CSSE and IT)

Int. Marks	Ext. Marks	Total Marks	L	T	P	C
40	60	100	3	-	-	3

#### PRE-REQUISITES: -

**COURSE DESCRIPTION:** Nature and Scope of Communication; Corporate Communication; Writing Business Messages & Documents; Careers and Résumés; Interviews.

**COURSE OUTCOMES:** After successful completion of this course, the students will be able to:

- CO1. Demonstrate knowledge of professional communication by examining and applying the styles and strategies of business communication in Communication Networks and Writing Messages.
- CO2. Analyze the limitations of business communication by applying and demonstrating corporate communication aspects for effective communication through Interpersonal Communication, Informal Communication, and Crisis Management and Communication.
- CO3. Apply appropriate writing techniques for effective professional communication in preparing documents by demonstrating and examining Stages in Writing Business Messages, Strategies for Writing the Body of a Letter, and Structuring Résumés.
- CO4. Apply appropriate speaking techniques by examining and demonstrating effective communication in distinguished situations through Corporate Communication and Cross Cultural Communication

#### DETAILED SYLLABUS:

##### UNIT- I: NATURE AND SCOPE OF COMMUNICATION (9 Periods)

Introduction: Communication Basics - Functions of Communication – Communication Networks - Interpersonal Communication – Informal Communication - Communication Barriers - Roles of a Manager.

##### UNIT- II: CORPORATE COMMUNICATION (9 Periods)

Introduction: Corporate Communication - Cross-Cultural Communication; Concept & Styles - Corporate Communication Strategy - Corporate Citizenship - Crisis Communication: Case Study.

##### UNIT- III: WRITING BUSINESS MESSAGES & DOCUMENTS (9 Periods)

Introduction: Importance of Written Business Communication - Types of Business Messages - Five Main Stages of Writing Business Messages – Business Letter Writing; Kinds of Business Letters – Common Components of Business Letters – Strategies for Writing the Body of a Letter.

**UNIT- IV: CAREERS AND RÉSUMÉS****(9 Periods)**

Introduction - Career Building - Résumé Formats; Traditional, Electronic and Video Resumés - Sending Résumés - Follow-up Letters - Business Presentations and Speeches; Planning -

Structuring - Organizing - Delivery.

**UNIT- V: INTERVIEWS****(9 Periods)**

Introduction - General Preparation for an Interview - Success in an Interview - Important Non-verbal Aspects - Types of Interviews - Styles of Interviewing - Types of Interviewing Questions - Online Recruitment Process.

**Total Periods: 45**

**Topics for Self Study are provided in the Lesson Plan**

**TEXT BOOKS:**

1. Meenakshi Raman and Prakash Singh, *Business Communication*, Oxford University Press, New Delhi, 2<sup>nd</sup> edition, 2012.
2. Neera Jain and Sharma Mukherji, *Effective Business Communication*, Tata McGraw-Hill Education, Pvt. Ltd., New Delhi, 2012.

**REFERENCE BOOKS:**

1. Courtland L. Bovee et al., *Business Communication Today*, Pearson, New Delhi, 2011.
2. Krizan, *Effective Business Communication*, Cengage Learning, New Delhi, 2010.

**ADDITIONAL LEARNING RESOURCES**

1. <http://www.career.vt.edu/interviewing/TelephoneInterviews.html>
2. [http://job-search-search.com/interviewing/behavioral\\_interviews](http://job-search-search.com/interviewing/behavioral_interviews)
3. <https://goo.gl/laEHOY> (dealing with complaints)
4. <http://www.adm.uwaterloo.ca/infocecs/CRC/manual/resumes.html>
5. <https://goo.gl/FEMGXS>
6. <http://www.resumania.com/arcindex.html>

### III B. Tech. - I Semester

#### (19BT4HS04) **ENTREPRENEURSHIP FOR MICRO, SMALL AND MEDIUM ENTERPRISES**

(Open Elective-1)

(Common to CE, ME, CSE, CSSE and IT)

Int. Marks	Ext. Marks	Total Marks	L	T	P	C
40	60	100	3	-	-	3

#### **PRE-REQUISITES: -**

**COURSE DESCRIPTION:** Introduction to Entrepreneur Development; Idea generation and formation of Business Plan; Micro and Small Enterprises; Institutional Finance and Support to Entrepreneur; Woman Entrepreneurship.

**COURSE OUTCOMES:** After successful completion of this course, the students will be able to:

- CO1. Demonstrate knowledge in concepts, functions, Micro and Macro units, NGOs, BharatiyaMahila Bank, Women Entrepreneurship, Schemes and Programmes.
- CO2. Analyze the idea generation, business plans, business acumen, institutional finance and rural entrepreneurship.

#### **DETAILED SYLLABUS:**

##### **UNIT – I: ENTREPRENEURSHIP DEVELOPMENT (9 Periods)**

Introduction to Entrepreneurship Development - Concept of Entrepreneurship – Growth of Entrepreneurship in India - Factors affecting Entrepreneurship growth - Characteristics of an Entrepreneur – Functions of Entrepreneur – Entrepreneurial Decision Process – Types of Entrepreneurs – Distinction between an Entrepreneur and a manager.

##### **UNIT – II: IDEA GENERATION AND FORMULATION OF BUSINESS PLANS**

**(9 Periods)**

Sources of Ideas – Methods of idea generation – Steps in Setting up of a Small Business Enterprise – Formulation of Business Plan – Contents and Significance of Business Plan – Common Errors in Business Plan Formulation – The role of incubation centers for promoting entrepreneurship and start-ups.

##### **UNIT – III: MICRO AND SMALL ENTERPRISES**

**(9 Periods)**

Meaning and Definition – Micro and Macro units – Essentials – Features – Characteristics – Scope of Micro and Small Enterprises – Objectives of Micro Enterprises – Relationship between Micro and Macro Enterprises- Problems of Micro and Small Enterprises

##### **UNIT – IV: INSTITUTIONAL FINANCE**

**(9 Periods)**

Institutional Finance – Need-Scope-Services - Various Institutions offering Institutional support: – Small Industries Development of Bank of India (SIDBI), State Industrial Development Corporations – Small Industries Development Organisation (SIDO) – Small Industries Service Institutes (SISIs) – SFCs - National Institute of Entrepreneurship and

Small Business Development (NIESBUD) – Micro Units Development and Refinance Agency Bank (MUDRA).

**UNIT –V: WOMEN & RURAL ENTREPRENEURSHIP**

**(9 Periods)**

Concept of Women entrepreneur - Functions of Women entrepreneurs - Growth of women entrepreneurship in India - Challenges of Women entrepreneurs- Programmes supporting women entrepreneurship – Rural Entrepreneurship – Meaning, Need for Rural entrepreneurship, Problems of rural entrepreneurship, Role of NGOs, Role of BharatiyaMahila Bank for encouraging Women Entrepreneurs – Micro Finance & Self Help Groups (Basic Concepts).

**Total Periods: 45**

***Topics for Self Study are provided in the Lesson Plan***

**TEXT BOOKS:**

1. Dr.S.S.Khanka, *Entrepreneurial Development*, S. Chand and Company Ltd, Revised edition, 2012.
2. MadhurimaLall & ShikhaSahai, *Entrepreneurship*, Excel Books India, 4<sup>th</sup> edition, 2014.

**REFERENCE BOOKS:**

1. Nandan, H., *Fundamentals of Entrepreneurship*, PHI Learning Pvt. Ltd., New Delhi, 3<sup>rd</sup> edition, 2013.
2. BholanathDutta, *Entrepreneurship Management – Text and Cases*, Excel Books, 3<sup>rd</sup> edition, 2015.



**III B. Tech. - I Semester**  
**(19BT4HS06) GERMAN LANGUAGE**  
(Open Elective-1)  
(Common to CE, ME, CSE, CSSE and IT)

Int. Marks	Ext. Marks	Total Marks	L	T	P	C
40	60	100	3	-	-	3

**PRE-REQUISITES: -**

**COURSE DESCRIPTION:** Oral communication; Basic grammar; Basic writing; Berufsdeutsch (Business German)

**COURSE OUTCOMES:** After successful completion of this course, the students will be able to:

CO1. Communicate everyday using familiar words with expressions and simple sentences.

**DETAILED SYLLABUS:**

**UNIT- I: INTRODUCTION (9 Periods)**

Introduction - German alphabets, numbers, days in a week, names of months, seasons. Grammar: Nouns –(i)Nominative case and (ii) Nominative personal pronouns, simple sentence, Verb Conjugation 1<sup>st</sup> and 2<sup>nd</sup> type, verb Conjugation 3<sup>rd</sup> type, 'Wh' questions (simple sentences) Nominative (definite and indefinite) Articles

**UNIT- II: CITY AND FOOD (9 Periods)**

In the city: naming places and buildings, means of transport, basic directions. Food: drink, groceries and meals. Apartments: rooms, furniture, colours. Grammar: Nouns-articles negation–(kein and nicht); imperative and the accusative case; Nominative Possessive Pronouns.

**UNIT- III: DAY TO DAY CONVERSATIONS (9 Periods)**

Everyday life, telling time, making appointments, leisure activities, and celebrations. Different types of professions, Health and the body, Holiday and weather, Clothes and Dresses.

**UNIT- IV: BASIC GRAMMAR (9 Periods)**

Grammar: Possessive articles, Prepositions (am, um, von. bis); Modal verbs, Separable verbs, the accusative, past tense of 'to have' and 'to be', the imperative sentences, dative case, perfect tense.

**UNIT- V: BASIC WRITING (9 Periods)**

Translation from English to German and German to English, Contacts, Writing letters and Email Writing.

**Total Periods: 45**

***Topics for Self Study are provided in the Lesson Plan***

**TEXT BOOKS:**

1. Heuber,Tangram Aktuelleins, HeuberVerlag Publications, 2011.

**REFERENCE BOOKS:**

1. Anta Kursisa, Gerhard Newner, Sara vicenta, Fir fuer Deutsch 1 und Deutsch 2, HeuberVerlag Publications, 2005.
2. Herman Funk, Studio D A1 Cornelsen, GOYAL SAAB Publication, Year 2011.

**III B. Tech. - I Semester**  
**(19BT4HS08) INDIAN HISTORY**  
(Open Elective-1)  
(Common to CE, ME, CSE, CSSE and IT)

Int. Marks	Ext. Marks	Total Marks	L	T	P	C
40	60	100	3	-	-	3

**PRE-REQUISITES: -**

**COURSE DESCRIPTION:** Introduction; Ancient India; Classical and Medieval era; Modern India; India after independence.

**COURSE OUTCOMES:** After successful completion of this course, the students will be able to:

- CO1. Demonstrate contextual knowledge on evolution of ancient and medieval Indian History and acquire awareness on societal and cultural issues.  
CO2. Analyze the situations before and after Independence and assess the societal reforms implemented in India after Independence.

**DETAILED SYLLABUS:**

**UNIT- I: INTRODUCTION (8 Periods)**

Elements of Indian History; History Sources: Archaeology, Numismatics, Epigraphy & Archival research; Methods used in History; History & historiography; sociological concepts-structure, system, organization, social institutions, Culture and social stratification (caste, class, gender, power), State & Civil Society.

**UNIT- II: ANCIENT INDIA (9 Periods)**

Mohenjo-Daro civilization; Harappa civilization; Mauryan Empire.

**UNIT- III: CLASSICAL & MEDIEVAL ERA (12 Periods)**

Classic Era (200 BC - 1200 AD); Hindu - Islamic Era (1200 - 1800 AD).

**UNIT- IV: MODERN INDIA (6 Periods)**

Age of Colonialism (17th - 19th centuries); First war of Indian Independence; Freedom Struggle (1857-1947).

**UNIT-V: INDIA AFTER INDEPENDENCE (1947 - ) (10 Periods)**

The Evolution of the Constitution and Main Provisions; Consolidation of India as a Nation; Politics in the States; Indian economy; Modernization and globalization, Secularism and communalism, Nature of development, Processes of social exclusion and inclusion, Changing Nature of work and organization.

**Total Periods: 45**

**Topics for Self Study are provided in the Lesson Plan**

**TEXT BOOK:**

1. K. Krishna Reddy, *Indian History*, Tata McGraw-Hill, 21<sup>st</sup> reprint, 2017.

**REFERENCE BOOKS:**

1. Guha, Ramachandra, *India after Gandhi*, Pan Macmillan, 2007.
2. Thapar, Romila, *Early India*, Penguin, 2002.

**III B. Tech. - I Semester**  
**(19BT4HS10) PERSONALITY DEVELOPMENT**  
 (Open Elective-1)  
 (Common to CE, ME, CSE, CSSE and IT)

Int. Marks	Ext. Marks	Total Marks	L	T	P	C
40	60	100	3	-	-	3

**PRE-REQUISITES:** A course on Soft Skills Laboratory

**COURSE DESCRIPTION:** Personalities and Leadership Qualities; Self Esteem and self Development; Attitude; Communication Relationship; Critical Work Skills and Ethics.

**COURSE OUTCOMES:** After successful completion of this course, the students will be able to:

- CO1 Demonstrate knowledge of leadership qualities by examining and applying personality traits through Positive self esteem, Open Communication and Self-Righteousness.
- CO2 Analyze the limitations of Attitudes by applying and demonstrating communication traits through Decision Making, Ethics and Self Actualization.
- CO3 Apply appropriate Analyzing techniques for comprehending different personalities by examining Positive and Negative Characteristic Traits and demonstrating through Leadership Styles, Mentoring and Behaviour Modification.
- CO4 Apply appropriate techniques in Solving Problems by examining and demonstrating Time Management, Stress Management and Anger Management.

**DETAILED SYLLABUS:**

**UNIT- I: PERSONALITIES AND LEADERSHIP QUALITIES (9 Periods)**

Introduction: Different Personalities - Personality Analysis - Freudian Analysis - Vedantic Concept: Swamy Vivekananda- Personality Begets - Types- Leadership Qualities - Decision Making - Case Studies: Personalities.

**UNIT- II: SELF ESTEEM AND SELF DEVELOPMENT (9 Periods)**

**Know Yourself:** Self Image - Positive Self Esteem -Turn Failure into Success - Be Sensitive to Feedback - Build Self Confidence - Self Actualization - Set Goals - Action Plans - Accountability - Behavior Modification - Mentoring - Learning- Counseling - Challenge yourself with Aptitude Tests and Internships.

**UNIT- III: ATTITUDE (9 Periods)**

Importance - Difference between Behavior and Attitude - Changing Negative Attitude- Impact of Attitudes on others - Unproductive Attitudes -Assess your Behaviour.

**UNIT- IV: COMMUNICATION RELATIONSHIP (9 Periods)**

Introduction - Positive and Negative Characteristic Traits - Grapevine Communication - Open Communication; Team Player - Leadership styles - Performance Expectations - Electronic Communication; Text Messaging - Voicemail - E-Mail

**UNIT- V: CRITICAL WORK SKILLS AND ETHICS (9 Periods)**

Time Management - Balancing Life and Work - Stress Management - Anger Management - Making Decisions and Solving Problems - Developing Creativity - Ethics and Self-Righteousness – Being Judgemental in the Real World - Striving for Integrity.

**Total Periods: 45**

**Topics for Self Study are provided in the Lesson Plan**

**TEXT BOOKS:**

1. Harold R. Wallace and L. Ann Masters, *Personal Development for Life and Work*, Cengage Learning, Delhi, 10<sup>th</sup> edition Indian Reprint, 2011. (6<sup>th</sup> Indian Reprint 2015)
2. Barun K. Mitra, *Personality Development and Soft Skills*, Oxford University Press, 2011.

**REFERENCE BOOKS:**

1. K. Alex, *Soft Skills*, S. Chand & Company Ltd, New Delhi, 2nd Revised Edition, 2011.
2. Stephen P. Robbins and Timothy A. Judge, *Organizational Behaviour*, Prentice Hall, Delhi, 16th edition, 2014.

**ADDITIONAL LEARNING RESOURCES**

1. <https://www.ncbi.nlm.nih.gov/pubmed/25545842>

**III B. Tech. - I Semester**  
**(19BT4HS12) WOMEN EMPOWERMENT**  
 (Open Elective-1)  
 (Common to CE, ME, CSE, CSSE and IT)

Int. Marks	Ext. Marks	Total Marks	L	T	P	C
40	60	100	3	-	-	3

**PRE-REQUISITES: -**

**COURSE DESCRIPTION:** Concept & Framework, Status of Women, Women's Right to work, International Women's Decade, and Women Entrepreneurship.

**COURSE OUTCOMES:** After successful completion of this course, the students will be able to:

- CO1. Demonstrate the characteristics of empowered women, their achievements, and frame work for women empowerment, legal laws, and political status of women.
- CO2. Apply the knowledge of women rights to address various societal issues and obstacles in different fields including science and technology.
- CO3. Understand the significance of participation in policy debates, National conferences and common forums for women's' equality and development.
- CO4. Analyze the concept of women entrepreneurship, government schemes and entrepreneurial challenges and opportunities.

**DETAILED SYLLABUS:**

**UNIT- I: CONCEPT & FRAMEWORK (9 Periods)**

Introduction- Empowered Women's Characteristics- Achievements of Women's Empowerment **Concept of Empowerment:** Meaning& Concept- Generalizations about Empowerment -Empowerment Propositions - Choices women can make for empowerment - Women's participation in decision making, development process & in Governance. **Framework for Women's Empowerment** - Five levels of equality- Tenets of Empowerment- Elements - Phases and aspects - Techniques - Categories and Models - Approaches.

**UNIT- II: STATUS OF WOMEN (9 Periods)**

**Legal Status:** Present Scenario- Call for Social change- Significant trends - Legal & Schemes - Personal Law- Joint Family- Criminal Law- Shift towards Dowry - Deterrent Punishment - Criminal Law(II Amendment) - Discrimination in Employment

**Political Status:** Present Scenario - Political Participation & its Nature- Socio-economic Characteristics - Political Mobilization: Mass Media - Campaign Exposure - Group Orientation - Awareness of issues and participation - Progress & Future Thrust.

**UNIT- III: WOMEN'S RIGHT TO WORK (9 Periods)**

Introduction- Present Scenario - Changes in Policy & Programme - National Plan of Action- Women's Cells and Bureau - Increase in work participation rate- Discrimination in labour market - Women in unorganized sector - Issues and Obstacles- Women in Education - Women in Science & Technology - **Case Study:** Linking Education to Women's Access to resources.

**UNIT- IV: WOMEN'S PARTICIPATORY DEVELOPMENT****(9 Periods)**

Dynamics of social change- conscious participation - Information Explosion - Organized Articulation - National Conference - Common Forums - Participatory Development - New Issues Identified - Role of other Institutions.

**UNIT- V: WOMEN ENTREPRENEURSHIP****(9 Periods)**

Introduction-Definition-Concept- Traits of women Entrepreneurs- Role of women Entrepreneurs in India -Reasons of Women Entrepreneurship- Government schemes & Financial Institutions to develop Women Entrepreneurs - Key policy recommendations - Project Planning-Suggestions and measures to strengthen women entrepreneurship - Growth & Future challenges - Training and Opportunities - **Case Study:** Training Women as Hand-pump Mechanics- **Case Study :** Literacy for Empowering Craftswomen

**Total Periods: 45**

***Topics for Self Study are provided in the Lesson Plan***

**TEXT BOOKS:**

1. Nayak Sarojini, Nair Jeevan(2017), "Women's Empowerment in India". Pointer Publishers, Jaipur
2. Sahay Sushama (2013), "Women and Empowerment" Discovery Publishing House, New Delhi.

**REFERENCE BOOKS:**

1. Baluchamy. S (2010), "Women's Empowerment of Women". Pointer Publishers, Jaipur.
2. Khobragade Grishma (2020), "Women's Empowerment: Challenges and Strategies Empowering Indian Women, Books clinic Publishing, Chhattisgarh.
3. <https://www.economicdiscussion.net/entrepreneurship/women-entrepreneurs-in-india>
4. <https://www.businessmanagementideas.com/entrepreneurship-2/women-entrepreneurs>

**III B. Tech. - I Semester**  
**(19BT4HS14) CONSTITUTION OF INDIA**  
**(Open Elective-1)**  
**(Common to CE, ME, CSE, CSSE and IT)**

Int. Marks	Ext. Marks	Total Marks	L	T	P	C
40	60	100	3	-	-	3

**PRE-REQUISITES: -**

**COURSE DESCRIPTION:** Preamble and its Philosophy; Union Legislature; Federalism in India; Judiciary and Public Services; Nation Building

**COURSE OUTCOMES:** After successful completion of this course, the students will be able to:

- CO1. Gain knowledge in Parliamentary proceedings, Election Commission, Public Services and Foreign Policy of India.
- CO2. Apply the reasoning informed by the various aspects in the Constitution, its provisions to assess societal issues and the consequent responsibilities relevant to the professional engineering practice.

**DETAILED SYLLABUS:**

**UNIT- I: PREAMBLE AND ITS PHILOSOPHY (8 Periods)**

Introduction and Evolution of Indian Constitution, preamble and its philosophy

**UNIT- II: UNION LEGISLATURE (9 Periods)**

The Parliament, Parliamentary Structure, Process of Legislation; President of India – Powers and Functions; Vice President, Prime Minister and Council of Ministers; Constitution Amendment Procedure and Financial Legislation.

**UNIT- III: FEDERALISM IN INDIA (10 Periods)**

Features of Federal System, Centre-State relations, Directive Principles of State Policy, Administrative Relationship between Union and States; Governors - Powers and Functions; State Legislature - Composition and powers; Chief Ministers - Powers and Functions, Council of Ministers; The Election Commission – Powers and Functions.

**UNIT- IV: JUDICIARY AND PUBLIC SERVICES (9 Periods)**

The Union Judiciary - Supreme Court and High Court; Fundamental Rights and Duties All India Services - Central Civil Services - State Services - Local Services.

**UNIT- V: INTERNATIONAL PARTICIPATION (9 Periods)**

Foreign Policy of India; International Institutions Influence: UNO, WTO, WHO, SAARC, International Summits: BRICS, NSS, UNEP – India's Role in International Negotiations; Environmentalism in India.

**Total Periods: 45**

**Topics for Self Study are provided in the Lesson Plan**

**TEXT BOOK:**

1. Brijji Kishore Sharma, Introduction to the Constitution of India, Prentice Hall of India, 2005.

**REFERENCE BOOK:**

1. Mahendra Pal Singh, V. N. Shukla's, Constitution of India, Eastern Book Company, 2011.
2. Pandey J. N., Constitutional Law of India - Central Law Agency, 1998.



**III B. Tech. - I Semester**  
**(19BT40205) RELIABILITY AND SAFETY ENGINEERING**  
 (Open Elective-1)  
 (Common to CE, ME, CSE, CSSE and IT)

Int. Marks	Ext. Marks	Total Marks	L	T	P	C
40	60	100	3	-	-	3

**PRE-REQUISITES:** Courses on Differential Equations and Multi-Variable Calculus & Transformation Techniques and Linear Algebra.

**COURSE DESCRIPTION:** Fundamentals of reliability engineering; Network modeling and reliability evaluation; Markov chain and Markov processes; basics of safety concepts and safety techniques and applications.

**COURSE OUTCOMES:** After successful completion of this course, the students will be able to:

- CO1. Develop mathematical model of a network to evaluate the parameters for assessing the reliability of a system.
- CO2. Analyze the time dependent/independent characteristics of a repairable system and frequency durations techniques to assess reliability.
- CO3. Understand various safety management, policy, and planning strategies for personal and industrial safety.
- CO4. Understand various safety and hazard identification techniques and follow appropriate safety measures in industry and society.

**DETAILED SYLLABUS:**

**UNIT-I: FUNDAMENTALS OF RELIABILITY ENGINEERING (9 Periods)**

Random variables, probability concepts, rules for probabilities of events. Probability density and distribution functions. Binomial distribution - Expected value and standard deviation for binomial distribution. Reliability functions,  $f(t)$ ,  $F(t)$ ,  $h(t)$  - Relationship between these functions, Exponential density and distribution functions, expected value and standard deviation of exponential distribution. Measures of reliability - MTTF, MTTR, MTBF. Bathtub curve.

**UNIT-II: NETWORK MODELING AND RELIABILITY EVALUATION (9 Periods)**

Basic concepts - Evaluation of network reliability/unreliability, series systems, parallel systems, series - Parallel configuration systems. Redundant systems and its types. Evaluation of network Reliability / Unreliability using conditional probability method, tie-set and cut-set based approach, complete event tree and reduced event tree methods.

**UNIT-III: MARKOV CHAIN AND MARKOV PROCESSES (9 Periods)**

Basic concepts, stochastic transitional Probability matrix, time dependent probability evaluation, Limiting State Probability evaluation, Absorbing states. Modelling concepts - State space diagrams, time dependent reliability evaluation of single component repairable model, two component repairable model. Frequency and duration techniques.

**UNIT IV: BASICS OF SAFETY CONCEPTS****(9 Periods)**

Introduction, goals, need for safety, history of safety movement - evolution of modern safety concept, general concepts of safety management. Planning for safety-productivity, quality and safety, line and staff functions, budgeting for safety, safety policy.

**UNIT V: SAFETY TECHNIQUES AND APPLICATIONS****(9 Periods)**

Introduction to safety techniques, Incident Recall Technique (IRT), disaster control, job safety analysis, safety survey, safety inspection, safety sampling, evaluation of performance of supervisors on safety. Hazard identification techniques, components of safety audit, types of audit, audit methodology, process of safety reporting. Applications of industrial Safety, environmental safety, health safety, electrical safety, fire safety.

**Total Periods: 45****Topics for Self Study are provided in the Lesson Plan****TEXT BOOKS:**

1. Roy Billinton and Ronald N Allen, *Reliability Evaluation of Engineering Systems*, 2<sup>nd</sup> edition, Springer, New York, 2013.
2. Frank R. Spellman, Nancy E. Whiting, *Safety Engineering: Principles and Practices*, 3<sup>rd</sup> edition, Rowman & Littlefield, 2018.

**REFERENCE BOOKS:**

1. Charles E. Ebeling, *An introduction to reliability and maintainability engineering*, 2<sup>nd</sup> edition Tata McGraw-Hill Education, 2010.
2. Dan Petersen, *Techniques of Safety Management: A Systems Approach*, 4<sup>th</sup> edition American Society of Safety Engineers, 2003.

**ADDITIONAL LEARNING RESOURCES:**

1. <https://nptel.ac.in/courses/105/108/105108128/>
2. <https://nptel.ac.in/courses/110/105/110105094/>
3. <https://www.youtube.com/watch?v=uutg8jKrL9w>
4. <https://www.youtube.com/watch?v=c-iZ2BAXPw>
5. <https://www.youtube.com/watch?v=GeMCF3s5EDk>
6. <https://www.youtube.com/watch?v=xYWyyype7cxE>

**III B. Tech. - II Semester**  
**(19BT50107) ENVIRONMENTAL POLLUTION AND CONTROL**  
 (Open Elective-1)  
 (Common to CE, ME, CSE, CSSE and IT)

Int. Marks	Ext. Marks	Total Marks	L	T	P	C
40	60	100	3	-	-	3

**PREREQUISITES: -**

**COURSE DESCRIPTION:** Fundamentals of air pollution; Dispersion of pollutants; Effects and control of air pollution; Water pollution; Soil pollution and control; Municipal solid waste management.

**COURSE OUTCOMES:** After successful completion of this course, the students will be able to:

- CO1 Analyze air and noise pollution using appropriate tools and techniques to solve complex environmental issues following relevant standards considering society, environment and sustainability besides communicating effectively in graphical form.
- CO2 Analyze air and noise pollution control measures using appropriate tools and techniques to solve complex environmental issues following relevant standards and latest developments considering society, environment and sustainability besides communicating effectively in graphical form.
- CO3 Analyze water pollution and its control measures using appropriate tools and techniques to solve complex environmental issues following relevant standards and latest developments considering society, environment and sustainability besides communicating effectively in graphical form.
- CO4 Analyze soil pollution and its control measures using appropriate tools and techniques to solve complex environmental issues following relevant standards and latest developments considering society, environment and sustainability besides communicating effectively in graphical form.
- CO5 Analyze solid waste and its management measures using appropriate tools and techniques to solve solid waste disposal issues following relevant standards and latest developments considering society, environment and sustainability besides communicating effectively in graphical form.

**DETAILED SYLLABUS:**

**UNIT- I: AIR AND NOISE POLLUTION**

**(8 Periods)**

**Air Pollution:** Scope, Significance, Classification, Sources – Line, Area, Stationary, Mobile; Effects of air pollutants on man, material and vegetation; Global effects of air pollution; Air pollution meteorology - Lapse rate, Inversion, Plume pattern; Dispersion of air pollutants - Dispersion models and applications; Ambient air quality standards.

**Noise Pollution:** Sound pressure, Power and intensity, Impacts of noise, permissible limits of noise pollution, measurement of noise, Noise standards.

**UNIT- II: AIR AND NOISE POLLUTION CONTROL**

**(10 Periods)**

Self cleansing properties of the environment, Dilution method, Control at source, Process changes and equipment modifications, Control of particulates–Types of equipment, Design and operation – Settling chambers, Centrifugal separators, Bag house filters, Wet scrubbers, Electrostatic precipitators; Control of gaseous pollutants – Adsorption,

Absorption, Condensation, Combustion; Control of air pollution from automobiles, Control of noise pollution, Case studies, Latest developments in the air and noise pollution control.

**UNIT– III: WATER POLLUTION AND CONTROL (10 Periods)**

Water pollution – Sources, Causes, Effects; Surface and groundwater quality – Physical, Chemical, Biological; Drinking water quality standards, Water purification – Processes, Engineered systems – Aeration, Solids separation, Settling operations, Coagulation, Softening, Filtration, Disinfection; Wastewater – Sources, Causes, Effects, Treatment process and disposal – Primary, Secondary, Tertiary; Case studies, Latest developments in the water pollution control.

**UNIT – IV: SOIL POLLUTION AND CONTROL (8 Periods)**

Soil pollutants, Sources of soil pollution, Causes, Effects and control of soil pollution, Diseases caused by soil pollution, Methods to minimize soil pollution, Effective measures to control soil pollution, Soil quality standards, Case studies, Latest developments in the soil pollution control.

**UNIT – V: MUNICIPAL SOLID WASTE MANAGEMENT (9 Periods)**

Municipal solid waste – Types, Composition and characteristics; Methods of collection and transportation; Methods of disposal – Open dumping, Sanitary landfill, Composting and

Incineration; Utilization -6R Concept, Recovery and recycling and Energy Recovery; Latest developments in solid waste management

**Total Periods: 45**

***Topics for Self Study are provided in the Lesson Plan***

**TEXT BOOKS:**

1. Peavy, H. S, Rowe, D. R., and Tchobanoglous, G., *Environmental Engineering*, McGraw Hill Inc., 1985.
2. C.S.Rao, *Environmental Pollution Control Engineering*, New Age International Pvt. Ltd., 2<sup>nd</sup> Edition, 2007.
3. Ibrahim A. Mirsa, *Soil Pollution: Origin, Monitoring & Remediation*, Springer, UK, 2<sup>nd</sup> Edition, 2008.

**REFERENCE BOOKS:**

1. M.N. Rao and H.V.N. Rao, *Air Pollution*, Tata McGraw–Hill Education Pvt. Ltd., 19<sup>th</sup> Edition, 2010.
2. Daniel Vallero, *Fundamentals of Air Pollution*, Academic Press (Elsevier), 5<sup>th</sup> Edition, 2014.
3. S.M.Khopkar, *Environmental Pollution Monitoring and Control*, New Age International Pvt. Ltd., 2<sup>nd</sup> Edition, 2007.
4. V. M. Domkundwar, *Environmental Engineering*, Dhanpat Rai & Co. Pvt. Ltd., New Delhi, 2014.

**ADDITIONAL LEARNING RESOURCES:**

1. *National Ambient Air Quality Standards*, Central Pollution Control Board, New Delhi
2. *Specifications for Drinking Water Standards*, IS10500:2012
3. *Solid Waste Management Rules*, 2016

**III B. Tech. - I Semester**  
**(19BT50108) PLANNING FOR SUSTAINABLE DEVELOPMENT**  
 (Open Elective-1)  
 (Common to CE, ME, CSE, CSSE and IT)

Int. Marks	Ext. Marks	Total Marks	L	T	P	C
40	60	100	3	-	-	3

**PREREQUISITES: -**

**COURSE DESCRIPTION:** Sustainable development; Environmental impact; Sustainable Policies; Governance; Theories and strategies; Media and education for sustainability.

**COURSE OUTCOMES:** After successful completion of this course, the students will be able to:

- CO1 Compare sustainable development theories in national and global context to protect the society and environment.
- CO2 Analyze the unforeseen environmental impacts on sustainable development to protect the society and environment.
- CO3 Analyze policies and governance for sustainable development considering ethics, economics, society and environment.
- CO4 Analyze systems and strategies for sustainable development using appropriate tools and techniques considering ethics, economics, society and environment.
- CO5 Analyze the role of media and education in sustainable development using appropriate tools and techniques considering ethics, society and environment besides communicating effectively.

**DETAILED SYLLABUS:**

**UNIT- I: SUSTAINABLE DEVELOPMENT (9 Periods)**

Definition and concepts of sustainable development, Capitalization of sustainability- National and global context; Sustainable development goals, Emergence and evolution of sustainability and sustainable development, Theories of sustainability, Case studies.

**UNIT -II: ENVIRONMENTAL IMPACT (9 Periods)**

Climate change – Science, Knowledge and sustainability; Unforeseen environmental impacts on development, Challenges of sustainable development, Centrality of resources in sustainable development, Case studies.

**UNIT- III: SUSTAINABLE POLICIES AND GOVERNANCE (9 Periods)**

Governance - Democracy and Eco-welfare; Global civil society and world civil politics, Civic environmentalism, Policy responses to sustainable development, Economics of sustainability, Social responsibility in sustainability, National action, ISO 14001: Environmental management system.

**UNIT- IV: SUSTAINABLE SYSTEMS AND STRATAGIES (9 Periods)**

Need for system innovation, Transition and co-evolution, Theories and methods for sustainable development, Strategies for eco-innovation, Ecological foot print analysis, Socio ecological indicators – Eco labels; Policy programmes for system innovation, Case studies.

**UNIT –V: MEDIA AND EDUCATION FOR SUSTAINABILITY (9 Periods)**

Role of emerging media, Remarkable design and communication art, Activism and the public interest, Education for sustainability, Participation in decision making, Critical thinking and reflection, Case studies.

**Total Periods: 45**

**Topics for Self Study are provided in the Lesson Plan**

**TEXT BOOKS:**

1. John Blewitt, *Understanding Sustainable Development*, Earth Scan Publications Ltd., 2<sup>nd</sup> Edition, 2008.
2. Jennifer A. Elliot, *An Introduction to Sustainable Development*, Earth Scan Publications Ltd., 4<sup>th</sup> Edition, 2006.

**REFERENCE BOOKS:**

1. Peter Rogers, Kazi F Jalal and John A Boyd, *An Introduction to Sustainable Development*, Earth Scan Publications Ltd., 2006.
2. Simon Dresner, *The Principles of Sustainability*, Earth Scan Publications Ltd., 2<sup>nd</sup> Edition, 2008.
3. Peter Bartelmus, *Environment Growth and Development: The Concepts and Strategies of Sustainability*, Routledge, 3<sup>rd</sup> Edition, 2003.
4. Gabriel Moser, Enric Pol, Yvonne Bernard, Mirilia Bonnes, Jose Antonio Corraliza and Maria Vittoria Giuliani, *People Places and Sustainability*, Hogrefe & Huber Publishers, 2<sup>nd</sup> Edition, 2003.

**ADDITIONAL LEARNING RESOURCES:**

1. Anil Markandya , *Climate Change and Sustainable Development: Prospects for Developing Countries*, Routledge, 2002

**III B. Tech. - I Semester**  
**(19BT50109) RURAL TECHNOLOGY**  
**(Open Elective-1)**

(Common to CE, ME, CSE, CSSE and IT)

Int. Marks	Ext. Marks	Total Marks	L	T	P	C
40	60	100	3	-	-	3

**PREREQUISITES: -**

**COURSE DESCRIPTION:** Technology for rural development; Nonconventional energy; Technologies for rural development; Community development; IT in rural development.

**COURSE OUTCOMES:** After successful completion of this course, the students will be able to:

- CO1 Compare various technologies for rural development by solving rural problems through different schemes by considering ethics, society, environment and sustainability.
- CO2 Analyze non conventional energy sources using appropriate tools and techniques to solve rural energy problems considering society, environment and sustainability besides communicating effectively in graphical form.
- CO3 Select appropriate technologies in different areas of rural development to solve rural issues following latest developments considering society, environment and sustainability.
- CO4 Relate water conservation, health, safety and rural employment issues for community development to solve rural problems through appropriate technologies considering ethics, society, environment and sustainability.
- CO5 Analyze the impact of IT, public and private partnership on rural development to solve complex rural problems using appropriate tools and techniques considering ethics, society, environment and sustainability.

**DETAILED SYLLABUS:**

**UNIT – I: TECHNOLOGY FOR RURAL DEVELOPMENT (09 Periods)**

India - Technology and rural development, Pre and post independence period, Rural India Life, Indian farmer, Role of science and technology in rural development, Rural technology and poverty eradication, Rural business hubs, Technology in improving rural infrastructure, Various organizations related to innovation, Issues of technology transfer - CAPART, NABARD, CSIR, NIF.

**UNIT – II: NON CONVENTIONAL ENERGY (09 Periods)**

Definition of energy, Types of alternative sources of energy, Sources of non conventional energy – Solar energy: Solar pump in agriculture, Solar dryer, Solar cooker, Solar heater; Biogas, Recycling and management, Wastes conservation, Assessment and production of biomass products and their utilization.

**UNIT – III: TECHNOLOGIES FOR RURAL DEVELOPMENT (09 Periods)**

Food and agro based technologies, Tissue culture, Nursery, Building and construction technologies, Cultivation and processing of economic plants, Cottage and social industries, Latest developments in rural technologies.

**UNIT – IV: COMMUNITY DEVELOPMENT****(09 Periods)**

Water conservation, Rain water Harvesting, Drinking water Standards and simple treatments used, Environment and Sanitation, Bio fertilizers, Medical and aromatic plants, Employment generating technologies–Apiculture, Pisciculture, Aquaculture.

**UNIT – V: IT IN RURAL DEVELOPMENT****(09 Periods)**

Role of information technology (IT) in rural areas, Impact of IT in rural development, Need and necessity of technology, Corporate social responsibilities, Private sector participation (Activities in different spheres: Employment, Education, Health, Agriculture and service sectors) and SaansadAdarsh Gram Yojana (SAGY), Village adoption schemes.

**Total Periods: 45**

**Topics for Self Study are provided in the Lesson Plan**

**TEXT BOOKS:**

1. Viridi, M. S., *Sustainable Rural Technologies*, Daya Publishing House, 2<sup>nd</sup> Edition, 2018.
2. Sprabhath. V., and P. Ch. Sita Devi, *Technology and Rural India*, Serials Publications, 1<sup>st</sup> Edition, 2012.

**REFERENCE BOOKS:**

1. Chakravarthy, R., and Murthy, P. R. S., *Information Technology and Rural Development*, Pacific Book International, 1<sup>st</sup> Edition, 2012.
2. Shivakanth Singh, *Rural Development Policies and Programmes*, Northern Book Centre, 1<sup>st</sup> Edition, 2002.
3. Katar Singh and Anil Shishodia, *Rural Development: Principles, Policies, and Management*, SAGE Publications India Private Limited, 4<sup>th</sup> Edition, 2016.
4. Vinayak Reddy, A., Yadagira Charyulu, M., *Rural Development in India: Policies & Initiatives*, New Century Publications, 1<sup>st</sup> Edition, 2008.

**ADDITIONAL LEARNING RESOURCES:**

1. Prasad, L. M., *Principles and Practice of Management*, S. Chand & Sons, 9<sup>th</sup> Edition, 2019.
2. Venkata Reddy, K., *Agriculture and Rural Development - Gandhian Perspective*, Himalaya Publishing House, 1<sup>st</sup> Edition, 2017.



**III B. Tech. - I Semester**  
**(19BT50505) ETHICAL HACKING**  
 (Open Elective-1)  
 (Common to CE, ME, CSE, CSSE and IT)

Int. Marks	Ext. Marks	Total Marks	L	T	P	C
40	60	100	3	-	-	3

**PREREQUISITES: -**

**COURSE DESCRIPTION:** Ethical hacking, Network and computer attacks, Footprinting, Social engineering, Port scanning, System hacking, Sniffers, Denial of service, Hacking web servers, Wireless hacking, Cryptography, Network Protection System.

**COURSE OUTCOMES:** After successful completion of this course, the students will be able to:

- CO1. Demonstrate knowledge on the computer security, social engineering and the intent of ethical hacking.
- CO2. Select and apply footprinting and port scanning tools to discover vulnerabilities of the computer system.
- CO3. Investigate hacking techniques and tools to maintain computer security.
- CO4. Analyze cryptosystems and network protection systems for information security and intrusion prevention.

**DETAILED SYLLABUS:**

**UNIT- I: ETHICAL HACKING, NETWORK AND COMPUTER ATTACKS (9 Periods)**

**Introduction to Ethical Hacking:** The role of security and penetration testers, Penetration-Testing methodologies, What you can and cannot do legally.

**Network and Computer Attacks:** Malicious software, Trojans, Backdoors, Viruses, and Worms, Protection against malware attacks, Intruder attacks on networks and computers, Addressing physical security.

**UNIT –II:-TCP/IP CONCEPTS AND SOCIAL ENGINEERING (9 Periods)**

**TCP/IP Concepts:** Overview of TCP/IP – Application layer, Transport layer, Internet layer; IP addressing – Planning IP address assignments, IPv6 addressing.

**Social Engineering:** What is social engineering, What are the common types of attacks, Understand insider attacks, Understand identity theft, Describe phishing attacks, Understand online scams, Understand URL obfuscation, Social engineering countermeasures.

**UNIT-III: FOOTPRINTING AND PORT SCANNING (9 Periods)**

**Footprinting:** Using web tools for footprinting, Conducting competitive intelligence, Using domain name system zone transfers.

**Port Scanning:** Port scanning, Using port scanning tools, Conducting ping sweeps, Understanding scripting.

**UNIT-IV: SYSTEM HACKING****(9 Periods)**

System hacking -Password cracking techniques, Types of passwords, Key loggers and other spyware technologies, Escalating privileges, Root kits, How to hide files, Steganography technologies, How to cover your tracks and evidences; Sniffers - Protocols susceptible to sniffing, Active and passive sniffing, ARP poisoning, Ethereal capture and display filters, MAC flooding, DNS spoofing techniques, Sniffing countermeasures; Denial of Service - Types of DoS attacks, How DDoS attacks work, How BOTs/BOTNETs work, Smurf attack, SYN flooding, DoS/DDoS counter measures; Session hijacking - Spoofing vs. hijacking, Types of session hijacking, Sequence prediction, Steps in performing session hijacking, Preventing session hijacking.

**UNIT-V: CRYPTOGRAPHY, NETWORK PROTECTION SYSTEMS****(9 Periods)**

**Cryptography:** Understanding Cryptography basics, Symmetric and asymmetric algorithms, Public key infrastructure, Cryptography attacks.

**Network Protection Systems:** Understanding routers, Firewalls, Honeypots.

**Total Periods: 45**

***Topics for Self Study are provided in the Lesson Plan***

**TEXT BOOKS:**

1. Michael T. Simpson, Kent Backman, James E. Corley, *Hands-On Ethical Hacking and Network Defense*, 3<sup>rd</sup>Edition, Cengage Learning, 2017.
2. Kimberly Graves, *CEH: Official Certified Ethical Hacker Review Guide*, Wiley, 2007.

**REFERENCE BOOK:**

1. Michael Gregg, *Certified Ethical Hacker (CEH) Cert guide*, 3<sup>rd</sup>Edition, Pearson, 2019.

**III B. Tech. - I Semester**  
**(19BT51207) AI IN HEALTHCARE**  
(Open Elective-1)  
(Common to CE, ME, CSE, CSSE and IT)

Int. Marks	Ext. Marks	Total Marks	L	T	P	C
40	60	100	3	-	-	3

**PREREQUISITES: -**

**COURSE DESCRIPTION:** Concepts of Artificial Intelligence (AI) in Healthcare; The Present State and Future of AI in Healthcare Specialties; The Role of Major Corporations in AI in Healthcare; Applications of AI in Healthcare.

**COURSE OUTCOMES:** After successful completion of this course, the students will be able to:

- CO1. Understand the fundamental concepts of AI in Healthcare sector.
- CO2. Understand the applications of AI in Healthcare specialties.
- CO3. Demonstrate AI applications developed by corporate companies.
- CO4. Demonstrate knowledge on future applications of Healthcare using AI.
- CO5. Understand the principles of AI applications through case studies.

**DETAILED SYLLABUS:**

**UNIT-I: INTRODUCTION TO ARTIFICIAL INTELLIGENCE IN HEALTHCARE  
(8 Periods)**

Introduction to AI in Healthcare, Benefits and Risks, AI in the health sector, AI versus Human Intelligence, The future of AI in health sector, AI and Neural networks.

**UNIT-II: THE PRESENT STATE AND FUTURE OF AI IN HEALTHCARE SPECIALTIES  
(10 Periods)**

**Artificial Intelligence in:** preventive healthcare, Radiology, Pathology, Surgery, Anesthesiology, Psychiatry, Cardiology, Pharmacy, Dermatology, Dentistry, Orthopedics, Ophthalmology.

**UNIT- III: THE ROLE OF MAJOR CORPORATIONS IN AI IN HEALTHCARE  
(08 Periods)**

IBM Watson, The role of Google and Deep mind in AI in Healthcare, Baidu, Facebook and AI in Healthcare, Microsoft and AI in Healthcare.

**UNIT- IV: FUTURE OF HEALTHCARE IN AI  
(10 Periods)**

Evidence-based medicine, personalized medicine, Connected medicine, Disease and Condition Management , Virtual Assistants, Remote Monitoring, Medication Adherence, Accessible Diagnostic Tests, Smart Implantables, Digital Health and Therapeutics, Education, Incentivized Wellness. Artificial Intelligence, Block chain, Robots, Robot-Assisted Surgery, Exoskeletons, Inpatient Care, Companions, Drones, Smart Places, Smart Homes, Smart Hospitals, Reductionism, Innovation vs. Deliberation.

## **UNIT- V: APPLICATIONS OF AI IN HEALTHCARE**

**(9 Periods)**

**Case Study 1:** AI for Imaging of Diabetic Foot Concerns and Prioritization of Referral for Improvements in Morbidity and Mortality.

**Case Study 2:** Outcomes of a Digitally Delivered, Low-Carbohydrate, Type 2 Diabetes Self-Management.

**Case Study 3:** Delivering a Scalable and Engaging Digital Therapy.

**Case Study 4:** Improving Learning Outcomes for Junior Doctors through the Novel Use of Augmented and Virtual Reality for Epilepsy

**Case Study 5:** Big Data, Big Impact, Big Ethics-Diagnosing Disease Risk from Patient Data.

**Total Periods: 45**

**Topics for Self Study are provided in the Lesson Plan**

### **TEXT BOOKS:**

1. Dr. Parag Mahajan, *Artificial Intelligence in Healthcare*, Med Manthra Publications, First Edition 2019.
2. Arjun Panesar, *Machine Learning and AI for Healthcare Big Data for Improved Health*, Apress Publications, 2019.

### **REFERENCE BOOKS:**

1. Michael Matheny, SonooThadaneyIsrani, Mahnoor Ahmed, and Danielle Whicher, *Artificial Intelligence in Health Care: The Hope, the Hype, the Promise, the Peril*, National Academy of Medicine Publication, First Edition, 2019.

### **ADDITIONAL LEARNING RESOURCES:**

1. <https://www.udacity.com/course/ai-for-healthcare-nanodegree--nd320>  
(AI for Healthcare).
2. <https://builtin.com/artificial-intelligence/artificial-intelligence-healthcare>  
(Surgical robots, new medicines and better care: 32 examples of AI in healthcare).
3. <https://healthtechmagazine.net/article/2020/02/future-artificial-intelligence-healthcare> (Future of Artificial Intelligence in Healthcare).

**III B. Tech. - I Semester**  
**(19BT51506) BIOINFORMATICS**  
(Open Elective-1)  
(Common to CE, ME, CSE, CSSE and IT)

Int. Marks	Ext. Marks	Total Marks	L	T	P	C
40	60	100	3	-	-	3

**PRE-REQUISITES:** A course on Biology for Engineers.

**COURSE DESCRIPTION:** Biological Data Acquisition, Databases, Data Processing, Methods of Analysis, Applications of Bio-informatics

**COURSE OUTCOMES:** After successful completion of this course, the students will be able to:

- CO1. Understand basic biological data acquisition in bioinformatics.
- CO2. Identify the proper databases for the information search by choosing the biological databases and also submission and retrieval of data from databases.
- CO3. Analyze the results of bioinformatics data using text and sequence-based searching techniques.
- CO4. Analyze the secondary and tertiary structures of proteins by applying different alignment programs
- CO5. Design biological databases and novel drugs by using contextual knowledge on bioinformatics.

**DETAILED SYLLABUS:**

**UNIT- I: BIOLOGICAL DATA ACQUISITION (9 Periods)**

Biological information, Retrieval methods for DNA sequence, protein sequence and protein structure information

**UNIT- II: DATABASES (9 Periods)**

Format and Annotation: Conventions for database indexing and specification of search terms, Common sequence file formats. Annotated sequence databases - primary and secondary sequence databases, protein sequence and structure databases.

**UNIT- III: DATA PROCESSING (9 Periods)**

Data – Access, Retrieval and Submission: Standard search engines; Data retrieval tools – Entrez, DBGET and SRS; Submission of (new and revised) data; Sequence Similarity Searches: Local and global. Distance metrics. Similarity and homology. Scoring matrices, PAM and BLOSUM

**UNIT- IV: METHODS OF ANALYSIS (9 Periods)**

Dynamic programming algorithms, Needleman-Wunsch and Smith-waterman. Heuristic Methods of sequence alignment, FASTA and BLAST; Multiple Sequence Alignment and software tools for pair wise and multiple sequence alignment, CLUSTAL program, Prediction of Tertiary structure of proteins.

**UNIT- V: APPLICATIONS****(9 Periods)**

Genome Annotation and Gene Prediction; ORF finding; Phylogenetic Analysis, Genomics, Proteomics, Genome analysis – Genome annotation, DNA Microarray, computer aided drug design (CADD).

**Total Periods: 45**

***Topics for Self Study are provided in the Lesson Plan***

**TEXT BOOKS:**

1. Lesk, A. K., "Introduction to Bioinformatics" 4th Edition, Oxford University Press, 2013
2. Dan Gusfield, "Algorithms on Strings, Trees and Sequences: Computer Science and Computational Biology" Cambridge University Press, 1997.

**REFERENCE BOOKS:**

1. Baldi, P. and Brunak, S., "Bioinformatics: The Machine Learning Approach" 2nd Edition, MIT Press. 2001
2. Mount, D.W., "Bioinformatics Sequence and Genome Analysis" 2nd Edition, Cold Spring Harbor Laboratory Press, 2004
3. Tindall, J., "Beginning Perl for Bioinformatics: An introduction to Perl for Biologists" 1st Edition, O'Reilly Media, 2001

### III B. Tech. – I Semester

#### (19BT50443) PRINCIPLES OF IMAGE PROCESSING

(Interdisciplinary Elective-1)

Int. Marks	Ext. Marks	Total Marks	L	T	P	C
40	60	100	3	-	-	3

#### PREREQUISITES: --

#### COURSE DESCRIPTION:

Fundamentals of digital image processing; Image transforms; Image enhancement techniques in spatial and frequency domains; Restoration techniques & image segmentation techniques; Morphological operations; Representation and description; Pattern recognition.

#### COURSE OUTCOMES:

On successful completion of this course, the students will be able to:

- CO1. Apply transformations on images by analyzing basic operations on images.
- CO2. Apply various image enhancement techniques in spatial and frequency domains to improve the quality of image.
- CO3. Apply restoration techniques based on noise models and degradation function to restore the images, pertaining to health and societal applications.
- CO4. Analyze various segmentation techniques on images for societal applications.
- CO5. Analyze appropriate techniques for morphological operations and reconstruction of images.
- CO6. Analyze various techniques to understand image features.

#### DETAILED SYLLABUS:

#### UNIT-I: DIGITAL IMAGE FUNDAMENTALS (09 periods)

Fundamental steps in digital Image Processing, Image sampling & quantization, some basic relationships between pixels, arithmetic operations, Logical operations, Spatial operations.

**Image Transforms:** 2D-DFT and properties, Walsh Transform, Hadamard Transform, Discrete Cosine Transform.

#### UNIT-II: IMAGE ENHANCEMENT (09 periods)

Basic Intensity transformation functions, Histogram processing, Fundamentals of Spatial Filtering, Smoothing spatial filters, Sharpening spatial filters, Basics of filtering in frequency domain, Image smoothing using frequency domain filters, Image sharpening using frequency domain filters, Homomorphic filtering.

#### UNIT-III: IMAGE RESTORATION AND SEGMENTATION (09 periods)

Image degradation/Restoration model, Estimating the degradation function, Inverse filtering, Weiner filtering, Constrained least squares filtering. Detection of discontinuities- Point, line and edge Detection. Thresholding-global thresholding, adaptive thresholding. Region based Segmentation.

#### UNIT-IV: MORPHOLOGICAL PROCESSING (09 periods)

Preliminaries, Erosion and Dilation, opening and closing, Some basic morphological algorithms- boundary extraction, extraction of connected components, thinning, thickening, skeletons, pruning, morphological reconstruction; gray scale morphology- Erosion and Dilation, opening and closing, gray scale morphology algorithms.

**UNIT-V: REPRESENTATION, DESCRIPTION AND RECOGNITION (09 periods)**

Chain codes, polygonal approximation, signatures, boundary segments, skeletons, boundary descriptors, regional descriptors, Pattern and pattern classes, recognition based on decision Theoretic methods- matching, optimum statistical classifiers.

**Total Periods: 45**

**Topics for Self Study are provided in the Lesson Plan**

**TEXT BOOKS:**

1. Rafael C. Gonzalez & Richard E. Woods, *Digital Image Processing*, Pearson Education, 3<sup>rd</sup> Edition, 2008.
2. Anil K. Jain, *Fundamentals of Digital Image processing*, Prentice Hall, 4<sup>th</sup> Edition, 2007.

**REFERENCE BOOKS:**

1. William K. Pratt, *Digital Image processing*, John Wiley & Sons Inc. 3<sup>rd</sup> Edition, 2001.
2. Earl Gose, Richard Johnsonbaugh, and Steve Jost, *Pattern Recognition and Image Analysis*, Pearson Education Services Pvt. Ltd, 1<sup>st</sup> Edition, 2015.



### III B. Tech. – I Semester

#### (19BT50205) ENERGY AUDIT, CONSERVATION AND MANAGEMENT

(Interdisciplinary Elective-1)

(Common to CE and EEE)

Int. Marks	Ext. Marks	Total Marks	L	T	P	C
40	60	100	3	-	-	3

**PRE-REQUISITES:** A course on Basic Electrical and Electronic Engineering.

**COURSE DESCRIPTION:** Principles of energy audit, management and conservation; Energy efficient motors, lighting schemes; Energy measuring instruments and significance of energy economics.

**COURSE OUTCOMES:** On successful completion of this course, the students will be able to:

- CO1. Apply the relevant rules, regulations and procedures of energy audit in industries and realize the energy management principles and protocols for effective conservation of energy.
- CO2. Analyze performance of energy efficient motors and propose appropriate illumination system by applying the protocols of energy auditing.
- CO3. Apply appropriate energy auditing instruments for energy auditing in industries and assess the economic benefits of auditing.
- CO4. Apply the demand side management techniques and relevant standards for organization of energy conservation awareness programs.

#### **DETAILED SYLLABUS:**

##### **UNIT-I: ENERGY AUDIT AND MANAGEMENT PRINCIPLES (10 Periods)**

Energy audit – definitions, concept, types of audit, energy index-cost index, pie charts, Sankey diagrams, load profiles, energy audit in industries, energy saving potential, energy audit of process industry, thermal power station, building energy audit, case study. IE rules and regulations for energy audit.

Energy management – Principles of energy management, organizing energy management program, initiating, planning, controlling, promoting, monitoring, reporting.

##### **UNIT-II: ENERGY CONSERVATION PRINCIPLES (08 Periods)**

Energy scenario in India and world. Rules for efficient energy conservation; technologies for energy conservation. Principles of energy conservation, current energy consumption in India, roles and responsibilities of energy managers in industries.

##### **UNIT-III: ENERGY EFFICIENT MOTORS AND LIGHTING (09 Periods)**

**Energy efficient motors** - factors affecting efficiency, loss distribution, constructional details, characteristics, variable speed, variable duty cycle systems, motor energy audit.

**Lighting** -Good lighting system design and practice, lighting control, lighting energy audit.

**UNIT-IV: ENERGY INSTRUMENTS AND ECONOMIC ANALYSIS (09 Periods)**

Energy Instruments— Infrared thermometer, data loggers, thermo-couples, pyrometers, Lux meters, tongue testers, power quality analyzer, and PLC and pic applications.

Energy Economic Analysis— The time value of money concept. Cash flow models, payback analysis, depreciation, taxes and tax credit - numerical problems.

**UNIT-V: DEMAND SIDE MANAGEMENT (09 Periods)**

Introduction to DSM, concept of DSM, benefits of DSM, different techniques of DSM – time of day pricing, multi-utility power exchange model, and time of day models for planning, load management, load priority technique; Management and organization of energy conservation awareness programs.

**Total Periods: 45**

**Topics for Self-study are provided in the Lesson Plan**

**REFERENCE BOOKS:**

1. W.R. Murphy & G. McKay Butter Worth, *Energy management*, Butter worth-Heinemann publications, 2<sup>nd</sup> Edition, 2016.
2. Albert Thumann, William J. Younger, *Handbook of Energy Audits*, Taylor & Francis Ltd, 7<sup>th</sup> edition, 2008.
3. Umesh Rathore, *Energy Management*, S.K. Kataria & Sons, 2<sup>nd</sup> Edition, 2014.
4. W.C. Turner, Stevedoty, *Energy Management Hand Book*, CRC press, 6<sup>th</sup> Edition, 2006.
5. D.P. Sen, K.R. Padiyar, Indrane Sen, M.A. Pai, *Recent Advances in Control and Management of Energy Systems*, Interline Publisher, Bangalore, 1993.
6. Ashok V. Desai, Wiley Eastern, *Energy Demand - Analysis, Management and Conservation Hand Book on Energy Auditing - TERI (Tata Energy Research Institute)*, 2005.
7. Craig B. Smith, Kelly E. Parmenter, *Energy Management Principles Applications*, benefits, Savings, Elsevier Inc (Pergamon Press), 1<sup>st</sup> Edition, 2016.

**ADDITIONAL LEARNING RESOURCES:**

1. <https://beeindia.gov.in/sites/default/files/1Ch3.pdf>
2. <https://www.youtube.com/watch?v=M1zijCmeXJg>
3. <https://www.youtube.com/watch?v=FTpMWXMBSyM>
4. [https://www.youtube.com/watch?v=T1Au\\_P5bnQ](https://www.youtube.com/watch?v=T1Au_P5bnQ)
5. <https://www.youtube.com/watch?v=ENLzwTVjxms>
6. <https://www.youtube.com/watch?v=7hDyLuFJ0c8>
7. <https://www.youtube.com/watch?v=lkNIuFkzxBk>

**USEFUL WEBSITES:**

1. <https://beeindia.gov.in/news-events/energy-conservation-building-code-rules-2018>
2. <https://beeindia.gov.in/content/energy-auditors>
3. <https://nayaenergy.com/difference-between-energy-audit-and-energy-management/>
4. <https://www.sgsgroup.in/en-gb/sustainability/environment/energy-services/energy-audits-and-management/energy-audit>
5. <https://www.consultivo.in/environment-energy/energy-audit-and-management/>
6. <https://www.teriin.org/energy>

7. <http://jnujprdistance.com/assets/lms/LMS%20JNU/Dual%20Degree%20Courses/PGD+MBA%20-%20Energy%20Management/Sem%20III/General%20Aspects%20of%20Energy%20Management%20and%20Energy%20Audit.pdf>

**III B. Tech. I-Semester**  
**(19BT70303) COMPUTATIONAL FLUID DYNAMICS**  
 (Interdisciplinary Elective – 1)

Int. Marks	Ext. Marks	Total Marks	L	T	P	C
40	60	100	3	-	-	3

**PRE-REQUISITES:** Courses on Multi-Variable Calculus and Differential Equations and Fluid Mechanics.

**COURSE DESCRIPTION:** Introduction to Computational Fluid Dynamics(CFD); Various Numerical methods; Solution methods for governing equations; Finite difference method and its application to heat transfer problems; Errors and stability analysis; Finite Volume method; Study flow analysis; Simple CFD techniques.

**COURSE OUTCOMES:**

On successful completion of this course, the students will be able to:

- CO 1: Apply governing equations of fluid dynamics for solving fluid mechanics and heat transfer problems.
- CO 2: Apply Discretization Techniques to solve algebraic equation of Grids with Appropriate Transformation.
- CO 3: Analyze numerical models of the Fluid flow and Heat transfer phenomenon using finite difference method as discretization and grid generation techniques for Parabolic Partial Differential Equations.
- CO 4: Analyze numerical models of the Fluid flow and Heat transfer phenomenon using finite difference method as discretization and grid generation techniques for elliptic and hyperbolic equations.
- CO 5: Analyze mathematical models of fluid dynamics using Finite volume approach.

**UNIT – I: GOVERNING EQUATIONS (9 periods)**

Introduction, applications of CFD in diverse fields, Governing equations of fluid dynamics – Continuity, Momentum and energy equations; Generic differential and integral form for governing equations, Initial and Boundary conditions, Differences between Finite element method, Finite difference method and Finite volume method, Classification of partial differential equations – Hyperbolic, Parabolic, Elliptic and Mixed types; Applications and relevance.

**UNIT – II: DISCRETIZATION TECHNIQUES (9 periods)**

**Basic Aspects of Discretization:** Introduction to finite differences, Finite difference equations using Taylor series expansion and polynomials, Explicit and implicit approaches, Uniform and unequally spaced grid points.

**Grids With Appropriate Transformation:** General transformation of the equations, Metrics and Jacobians, The transformed governing equations of the CFD, Boundary fitted coordinate systems, Algebraic and elliptic grid generation techniques, Adaptive grids.

**UNIT – III: FINITE DIFFERENCE FORMULATIONS (9 periods)**

**Parabolic Partial Differential Equations:** Finite difference formulations, Explicit methods – FTCS, Richardson and DuFort-Frankel methods, Implicit methods – Laasonen, Crank-Nicolson and Beta formulation methods, Approximate factorization, Fractional step methods, Consistency analysis, Linearization.

**Stability Analysis:** Discrete Perturbation Stability analysis, von Neumann Stability analysis, Error analysis, Modified equations, Artificial dissipation and dispersion.

**UNIT – IV: ELLIPTIC AND HYPERBOLIC EQUATIONS****(9 periods)**

**Elliptic Equations:** Finite difference formulation, solution algorithms: Jacobi-iteration method, Gauss-Siedel iteration method, point- and line-successive over-relaxation methods, alternative direction implicit methods.

**Hyperbolic Equations:** Explicit and implicit finite difference formulations, splitting methods, multi-step methods, applications to linear and nonlinear problems, linear damping, flux corrected transport, monotone and total variation diminishing schemes, tvd formulations, entropy condition, first-order and second-order TVD schemes, introduction to modern tools.

**UNIT – V: FINITE VOLUME METHOD****(9 periods)**

Introduction, Finding the flux at interface, Central schemes - Lax-Friedrichs Method, Lax-Wendroff Method, Two-Step Lax-Wendroff Method and MacCormack Method; Upwind Method in Finite Volume methods - Flux Splitting Method Steger and Warming, vanLeer, Roe's Method and finding Roe's Averages; Numerical procedure for SIMPLE algorithm, Boundary conditions for the pressure correction method; Stream function, Vorticity method, introduction to modern tools.

**Total periods: 45****Topics for self-study are provided in lesson plan****TEXT BOOKS:**

1. John. D. Anderson, *Computational Fluid Dynamics, The Basics with Applications*, Mc Graw Hill. Indian Edition, 2017.
2. Hoffman, K. A., and Chiang, S. T., *Computational Fluid Dynamics, Vol. I, II and III*, Engineering Education System, Kansas, USA, 2000.

**REFERENCE BOOKS:**

1. Tapan K. Sengupta, *Fundamentals of Computational Fluid Dynamics*, 1<sup>st</sup> Edition, Universities Press, 2004.
2. Suhas V. Patankar, *Numerical Heat Transfer and Fluid Flow*, 1<sup>st</sup> Edition, CRC, 1980.

### III B. Tech. – I Semester

#### (19BT50105) CONSTRUCTION EQUIPMENT AND AUTOMATION

(Interdisciplinary Elective 1)

Int. Marks	Ext. Marks	Total Marks	L	T	P	C
40	60	100	3	-	-	3

**PRE - REQUISITES:** Course on Construction, Planning and Project Management

**COURSE DESCRIPTION:** Construction equipment and management; Earthwork equipment and material handling equipment; Asphalt and concrete plants and other construction equipment; Building automation system; Automation and robotics in construction.

**COURSE OUTCOMES:** On successful completion of this course, the students will be able to:

- CO1. Categorize construction equipment to solve complex construction problems considering safety, project management and finance besides communicating effectively in graphical form.
- CO2. Analyze earthwork and material handling equipment to solve complex construction problems ensuring safety and environment besides communicating effectively in graphical form.
- CO3. Analyze asphalt and concrete plants and other construction equipment to solve construction problems following latest developments ensuring safety and environment besides communicating effectively in graphical form.
- CO4. Analyze building automation system to solve construction problems using appropriate tools and techniques following relevant standards and latest developments considering society, project management and finance besides communicating effectively in graphical form.
- CO5. Analyze automation and robotics in construction to solve construction problems using appropriate techniques following latest developments considering society, project management and finance besides communicating effectively in graphical form.

#### **DETAILED SYLLABUS:**

##### **UNIT I CONSTRUCTION EQUIPMENT AND MANAGEMENT (8 periods)**

Identification, Planning of equipment, Selection of Equipment, Equipment Productivity, Equipment Management in Projects, Maintenance Management, Equipment cost, Operating cost, Cost Control of Equipment, Depreciation Analysis, Replacement of Equipment, Replacement Analysis, Safety Management

##### **UNIT II EARTHWORK EQUIPMENT AND MATERIAL HANDLING EQUIPMENT**

**(10 Periods)**

**Earthwork Equipment:** Fundamentals of Earth Work Operations, Earth Moving Operations, Types of Earth Work Equipment - Tractors, Motor Graders, Scrapers; Front end Waders – Dozer, Excavators, Rippers, Loaders, Compacting Equipment, Finishing equipment.

**Material Handling Equipment:** Forklifts and related equipment, Portable Material Bins, Conveyors, Trucks and Hauling equipment.

### **UNIT III ASPHALT AND CONCRETE PLANTS AND OTHER CONSTRUCTION EQUIPMENT (10 Periods)**

**Asphalt and Concrete plants:** Aggregate production, Different Crushers, Feeders, Screening Equipment, Handling Equipment, Batching and Mixing Equipment, Pumping Equipment, Ready mix concrete equipment, Concrete pouring equipment. Asphalt Plant, Asphalt Pavers, Asphalt compacting Equipment

**Other Construction Equipment:** Equipment for Dredging, Trenching, Drag line and clamshells, Tunnelling, Equipment for Drilling and Blasting, Pile driving Equipment, Erection Equipment, Crane, Mobile crane, Types of pumps used in Construction, Equipment for Dewatering and Grouting, Equipment for Demolition

### **UNIT - IV BUILDING AUTOMATION SYSTEM (8 Periods)**

Building Automation System (BAS) - Concept, Applications, Requirements, Design considerations, Effect on functional efficiency, Architecture and Components of BAS; Building Information Modelling (BIM) – Construction life cycle using BIM, Applications; Sensors to collect and process data, Virtual reality during project planning, training and management.

### **UNIT - V AUTOMATION AND ROBOTICS IN CONSTRUCTION (9 Periods)**

**Automation:** Advantages and disadvantages, Need, Applications - Automation in precast construction industry, high rise building construction, prefabrication of masonry, onsite masonry construction, manufacture of brick wall masonry blocks, timber construction, production of steel components; Autonomous machines on the construction site, Drones to survey working areas, Automatic concrete screeding machine.

**Robotics in Construction:** Tele-operated robots, Programmed Robots and Cognitive Robots - Use of robots for repetitive activities; Challenges in construction robotics, Robotics in concrete works, Concrete surface finishing robot, Transformable welding robot.

**Total periods: 45**

**Topics for self-study are provided in lesson plan**

#### **TEXT BOOKS:**

1. Sharma, S.C. *Construction Equipment and Management*, Khanna Publishers, New Delhi, 6<sup>th</sup> Edition, 2015.
2. Mahesh Varma, *Construction Equipment and its Planning and Application*, Metropolitan Book Company, New Delhi. 1983.

#### **REFERENCE BOOKS:**

1. Deodhar, S.V., *Construction Equipment and Job Planning*, Khanna Publishers, New Delhi, 1988.
2. Peurifoy, R.L., Ledbetter, W.B. and Schexnayder, C., *Construction Planning, Equipment and Methods*, McGraw Hill, Singapore, 2006.
3. Thomas Boak and Thomas Linner, *Construction Robots - Elementary Technologies and Single-Task Construction Robot*, Cambridge University Press, 2017.
4. Bimal Kumar, *A Practical Guide to Adopting BIM in Construction Projects*, Whittles Publishing Pvt. Ltd., Dunbeath, Scotland, 2015.

**ADDITIONAL LEARNING RESOURCES:**

1. Carpehart, B. L. and Lynne C. Capehart, *Web Based Enterprize Energy and Building Automation Systems*, Fairmont Press, 2007.
2. Mikell P. Groover, *Automation Production System and Computer - Integrated Manufacturing*, Pearson Higher Education, Inc., 4<sup>th</sup> Edition, 2015.



### III B. Tech. I Semester

#### (19BT50106) PIPELINE ENGINEERING

(Interdisciplinary Elective-1)

Int. Marks	Ext. Marks	Total Marks	L	T	P	C
40	60	100	3	-	-	3

**PRE-REQUISITES:** Course on Fluid Mechanics, Hydraulic Engineering.

**COURSE DESCRIPTION:** Elements of pipeline design and route selection; Pressure drop calculations; Gas compression and coolers; Pumps and transient flow in liquid; Pipeline design.

**COURSE OUTCOMES:** On successful completion of this course, the students will be able to:

- CO1 Analyze elements of pipeline design and route selection to solve pipeline engineering problems using appropriate techniques by following relevant codes and standards considering society, environment and economics besides communicating effectively in graphical form.
- CO2 Analyze pressure drop calculations to solve complex pipeline engineering problems using appropriate techniques by following relevant codes for the benefit of the society considering environment besides communicating effectively in graphical form.
- CO3 Analyze gas compressors and coolers to solve complex pipeline engineering problems using appropriate techniques by following relevant codes considering safety and environment besides communicating effectively in graphical form.
- CO4 Design pump station piping for the fluid flow to solve complex pipeline engineering problems using appropriate techniques by following relevant codes considering safety and environment besides communicating effectively in graphical form.
- CO5 Analyze transient flow in liquid to solve complex pipeline engineering problems using appropriate techniques considering safety and environment besides communicating effectively in graphical form.
- CO6 Design a pipeline to solve complex pipeline engineering problems using appropriate techniques by following relevant codes considering safety and environment besides communicating effectively in graphical form.

#### **DETAILED SYLLABUS:**

##### **UNIT I- ELEMENTS OF PIPELINE DESIGN AND ROUTE SELECTION (09 periods)**

**Elements of Pipeline Design:** Scope of Pipeline Engineering; History of Pipelines in India, Fluid properties; Environment - Effects of pressure and temperature; Supply/Demand scenario; Codes and standards – Environmental and hydrological considerations; Economics - Materials/Construction – Operation; Pipeline protection - Pipeline integrity monitoring.

**Pipeline Route Selection:** Introduction - Preliminary route selection - Key factors for route selection; Engineering survey - Legal survey - Construction /As-built survey - Geotechnical design.

**UNIT II – PRESSURE DROP CALCULATIONS (09 periods)**

General flow equation – Weymouth Equation, Panhandle A equation, Panhandle B Equation, Steady state; Transmission Factor, Effect of Pipeline Elevation (Single Slope, Multiple Slope), Pressure drop calculation for pipeline in series and parallel; Pipeline gas velocity –Erosional velocity, Friction Factor Calculations.; Optimum pressure drop for design purposes; Pipeline packing –Determining gas leakage using pressure drop method; Wall thickness/pipe grade; Temperature profile – Optimization process – Gas transmission solved problems.

**UNIT III – GAS COMPRESSION AND COOLERS (09 periods)**

**Gas Compression:** Types of compressors; Compressor drivers; Compressor station configuration; Thermodynamics of isothermal and adiabatic gas compression; Temperature change in adiabatic gas compression; Thermodynamics of polytropic gas compression; Gas compressors in series; Centrifugal compressor horsepower; Enthalpy / Entropy charts (Mollierdiagram); Centrifugal compressor performance curve; Reciprocation compressors.

**Coolers:** Gas coolers – Aircooled heat exchangers; Heat transfer equations for coolers; Fan air mass flow rate; Required fan power; Gas pressure drop in coolers; Iterative procedure for calculations based on unknown  $T_2$ .

**UNIT IV –PUMPS AND TRANSIENT FLOW IN LIQUID (8 periods)**

**Pumps:** Fully developed laminar flow in a pipe; Turbulent flow; Centrifugal pumps – Retrofitting for centrifugal pumps (Radial-flow); Pump station control – Pump station piping design.

**Transient Flow in Liquid:** Purpose of transient analysis; Theoretical fundamentals and transient solution technique; Applications – Computer applications.

**UNIT V – PIPELINE DESIGN (10 periods)**

**Pipeline Mechanical Design:** Codes and standards, Location classification; Pipeline design formula, Expansion and flexibility, Joint design for pipes of unequal wall thickness; Value assemblies, Scraper traps, Buoyancy control; Crossings – Depth of cover – Aerial markings –Warning signs; Pipeline Construction and Commissioning.

**Materials Selection:** Elements of design – Materials designation standards.

**Pipeline Protection:** Pipeline coating; Cathodic protection –Cathodic protection calculations for land pipelines; Internal corrosion; Flow meters and their calibration – Sensors – Pigs.

**Total Periods: 45**

**Topics for self-study are provided in the lesson plan.**

**TEXT BOOKS:**

1. Mahitpour, M., Golshan, H. and Murray, M.A., *Pipeline Design and Construction: A Practical Approach*, ASME Press, 3<sup>rd</sup> Edition, 2010.
2. Henry Liu, *Pipeline Engineering*, Lewis Publishers (CRC Press), 2003.

**REFERENCE BOOKS:**

1. George, A., Antaki, *Piping and Pipeline Engineering-Design, Construction, Maintenance Integrity and Repair*, CRC Press, 2003.
2. Alkazraji, D., *A Quick Guide to Pipeline Engineering*, Woodhead Publishing, 2008.
3. ShashiMenon, E., *Pipeline Planning and Construction Field Manual*, Gulf Professional Publishing, 2011.
4. McAllister, E. W., *Pipeline Rules of Thumb Handbook*, 7<sup>th</sup> Edition, 2009.

**ADDITIONAL LEARNING RESOURCES:**

1. ShashiMenon, E., *Liquid Pipeline Hydraulics*, Mareel Dekker, Inc., 2004.
2. Skonberg Eric, R., and Tennyson, M., Muindi, *Pipeline Design for Installation by Horizontal Directional Drilling*, American Society of Civil Engineers, 2014.

### III B. Tech. – I Semester

#### (19BT50131) **COMPUTER AIDED BUILDING PLANNING AND DRAWING**

Int. Marks	Ext. Marks	Total Marks	L	T	P	C
50	50	100	-	-	2	1

**PRE-REQUISITES:** Course on Civil Engineering Materials and Concrete Technology, Construction, Planning and Project Management.

**COURSE DESCRIPTION:** Exercises on Conventional signs and symbols used in building drawing; Planning and computer aided drawing of Load bearing walls, RCC framed structures and industrial buildings.

**COURSE OUTCOMES:** On successful completion of this course, the students will be able to:

- CO1 Analyze conventional signs and symbols used in building drawing using Auto CAD following relevant standards.
- CO2 Develop complex 2D plans, elevations and sections of doors, windows, isolated footings, buildings and RCC framed structures using Auto CAD by adopting building bye-laws and principles of planning considering safety, serviceability and environment.
- CO3 Develop complex 2D sectional views of various trusses using Auto CAD by adopting building bye-laws considering safety and serviceability.
- CO4 Develop complex 3D perspective views of one and two storey buildings using Auto CAD by adopting building bye-laws.
- CO5 Perform individually or in a team besides communicating effectively in written, oral and graphical forms in connection with building planning and drawing.

#### **DETAILED SYLLABUS:**

**SOFTWARE:** Auto CAD

#### **LIST OF EXERCISES:**

1. Conventional signs in building drawing
2. Elevation and sectional view of doors
3. Elevation and sectional view of windows
4. Sectional view of Isolated footings
5. Plan, elevation and sectional views of building (Load bearing wall structure)
6. Plan, section and elevation of RCC framed structures
7. King post truss with details
8. Queen post truss with details
9. North light roof truss with details
10. Perspective view of one storey buildings
11. Perspective view of two storey buildings

#### **TEXT BOOKS:**

1. Varma B. P., *Civil Engineering Drawing and House Planning*, Khanna Publishers, 12<sup>th</sup> Edition, 2006.
2. Balagopal and Prabhu, T. S., *Building Design and Civil Engineering Drawing*, Spades Publishers, 2012.

**REFERENCE BOOKS:**

1. Shah, M. G., Kale, C. M., and Patki. S, Y., *Building Drawing with an Integrated Approach to Built Environment*, Tata McGraw–Hill, 5<sup>th</sup> Edition, 2012.
2. Kumaraswamy N. and KameswaraRao A., *Building Planning and Drawing*, Charotar Publishing House Pvt. Ltd., 9<sup>th</sup> Edition, 2019.
3. Natarajan, K. V., *A Text Book of Engineering Graphics*, N. Dhanalakshmi Publishers, 21<sup>st</sup> Edition, 2018.
4. Bhavikatti, S. S., & Chitawadagi, M. V., *Building Planning and Drawing*, I.K. International Publishing House Pvt. Ltd., 2014.

**LABORATORY MANUALS:**

1. *Computer Aided Building Planning and Drawing Laboratory Manual (SVEC19 Regulations)*, Department of Civil Engineering, Sree Vidyanikethan Engineering College, Tirupati.

**CODES**

- SP 7 Group I – 2016 : National Building code of India  
SP 27 – 2013 : Handbook for method of measurement of building works  
SP 62 – 1997 : Handbook on Building Construction Practices

### III B. Tech. – I Semester

#### (19BT50132) **TRANSPORTATION ENGINEERING LAB**

Int. Marks	Ext. Marks	Total Marks	L	T	P	C
50	50	100	-	-	2	1

**PRE-REQUISITES:** Course on Transportation Engineering

**COURSE DESCRIPTION:** Highway material testing – Aggregates, Bituminous materials, Bituminous mixes; Pavement evaluation; Traffic studies.

**COURSE OUTCOMES:** On successful completion of this course, the students will be able to:

- CO1 Evaluate road aggregates using different tools and techniques to solve complex highway engineering problems following relevant codes of practice and latest trends ensuring safety and environment.
- CO2 Evaluate bituminous materials using different tools and techniques to solve complex highway engineering problems following relevant codes of practice and latest trends ensuring safety and environment.
- CO3 Design bituminous mix for pavements using different tools and techniques to solve complex highway engineering problems following relevant codes of practice and latest trends ensuring safety, environment and sustainability.
- CO4 Evaluate pavements using different tools and techniques to solve complex highway engineering problems following relevant codes of practice and latest trends ensuring safety and environment.
- CO5 Evaluate macroscopic and microscopic parameters of traffic using different tools and techniques to solve complex traffic engineering problems following relevant codes of practice and latest trends ensuring safety and environment.
- CO6 Perform individually or in a team besides communicating effectively in written, oral and graphical forms on transportation engineering.

#### **LIST OF EXPERIMENTS:**

##### **(A) AGGREGATES**

1. Sieve analysis of aggregates
2. Shape test and angularity number test for coarse aggregate
3. Aggregate crushing value test and 10% fines value
4. Aggregate impact test
5. Attrition test for coarse aggregate
6. Abrasion test for coarse aggregate
7. Specific gravity and water absorption test

##### **(B) BITUMINOUS MATERIALS**

8. Penetration test
9. Ductility test
10. Softening point test
11. Flash and fire point test
12. Viscosity test
13. Specific gravity test

##### **(C) BITUMINOUS MIXES**

14. Marshall stability test on Marshall bituminous mix design
15. Stripping value test of coated bituminous mix
16. Theoretical maximum specific gravity ( $G_{mm}$ ) of bituminous mix test

17. Bitumen extraction and determination of bitumen content and gradation of aggregates

**(D) PAVEMENT EVALUATION**

18. Field CBR test for subgrade strength
19. Benkelman beam deflection studies on flexible pavement and analysis
20. Measurement of unevenness/roughness by MERLIN or Bump Integrator

**(E) TRAFFIC STUDIES**

21. Spot speed studies
22. Traffic volume studies at mid-block section and at typical intersections

**TEXT BOOKS:**

1. Khanna, S.K. Justo, C. E. G., and Veeraragavan, A., *Highway Materials and Pavement Testing*, Nem Chand & Bros, Roorkee, Revised 5<sup>th</sup> Edition, 2009.
2. Khanna, S. K. and Justo, C. E. G., *Highway Engineering*, Nem Chand & Bros, Roorkee, Revised 10<sup>th</sup> Edition, 2014.

**REFERENCE BOOKS/LABORATORY MANUALS:**

1. *Transportation Engineering Laboratory Manual (SVEC19 Regulations)*, Department of Civil Engineering, Sree Vidyanikethan Engineering College, Tirupati.
2. Partha Chakroborthy and Animesh Das, *Principles of Transportation Engineering*, Prentice Hall of India Pvt. Ltd, 2<sup>nd</sup> Edition, 2017.

**ADDITIONAL LEARNING RESOURCES:**

1. Athanassios Nikolaidis, *Highway Engineering: Pavements, Materials and Control of Quality*, Taylor and Francis Group, LLC, 1<sup>st</sup> Edition, 2017.

**CODES:**

- IS 2386-1963 (Part I to IV) : Methods of Test for Aggregates for Concrete.  
IS 1201-1220 (1978) : Methods for Testing Tar and Bituminous Materials.

### III B.Tech. - I semester

#### (19BT50133) **SOCIALLY RELEVANT PROJECT-1**

Int. Marks	Ext. Marks	Total Marks	L	T	P	C
50	50	100	-	-	-	1

**PREREQUISITES:** -

**COURSE DESCRIPTION:** Identification of topic for the socially relevant project; Literature survey; Collection of preliminary data; Identification of implementation tools and methodologies; Performing critical study and analysis of the topic identified; Time and cost analysis; Implementation of the socially relevant project; Preparation of thesis and presentation.

**COURSE OUTCOMES:** On successful completion of the course, the students will be able to:

- CO1 Create/Design engineering systems or processes to solve complex societal problems using appropriate tools and techniques following relevant standards, codes, policies, regulations and latest developments.
- CO2 Consider environment, sustainability, economics and project management in addressing societal problems.
- CO3 Perform individually or in a team besides communicating effectively in written, oral and graphical forms on socially relevant project.



### III B.Tech. I Semester

#### (19BT503AC) FOUNDATIONS OF ENTREPRENEURSHIP

(Audit Course)

(Common to CE, ME, EEE, ECE and EIE)

Int. Marks	Ext. Marks	Total Marks	L	T	P	C
-	-	-	2	-	-	-

**PREREQUISITES:** -

**COURSE DESCRIPTION:** The nature and growth of entrepreneurship; Characteristics of an entrepreneur; Types of Entrepreneurs; Ethics and social responsibility of entrepreneurs; Generating ideas; Opportunity identification; Implementing and managing the venture; Principles of creativity and innovation; Methods of protecting innovation and creativity; Market research; Feasibility analysis; Sources of funding; Preparation of business plan; Start-Ups; Social Entrepreneurship; Rural entrepreneurship.

**COURSE OUTCOMES:** After successful completion of this course, the students will be able to:

- CO1:** Demonstrate knowledge on personal attributes that enable best use of entrepreneurial opportunities.
- CO2:** Apply suitable method to protect creativity and innovation.
- CO3:** Design and prepare high impact strategic and business plan.
- CO4:** Analyze the major steps and requirements in order to convert innovative idea into a successful start-up.
- CO5:** Develop an idea to create a business for social change by identifying social entrepreneurship opportunities.

**DETAILED SYLLABUS :**

**UNIT-I: ENTREPRENEURIAL MINDSET (06 Periods)**

The nature and growth of entrepreneurship, Entrepreneurship and Intrapreneurship, Characteristics of an entrepreneur, Types of Entrepreneurs, Women as an Entrepreneur, Factors that contribute to the success of entrepreneurs, Ethics and social responsibility of entrepreneurs.

**UNIT-II: ENTREPRENEURIAL PROCESS (06 Periods)**

Generating ideas, Opportunity identification, Business concepts, Resources (Financial, Physical and Human), Implementing and managing the venture, Harvesting the venture, Harvesting strategies: Absorption of new concept into mainstream operations, Licensing of rights, Family succession, Liquidate (Shut down) venture, Selling the venture, Management Buy-Out (MBO).

**UNIT-III: CREATIVITY AND INNOVATION (06 Periods)**

Principles of creativity and innovation, Disruptive, incremental and open innovations, Nurturing and managing innovation, Methods of protecting innovation and creativity: Intellectual property rights, Branding, Trademarks, Patents, Copyrights, Registered design protection, Trade secrets.

**UNIT-IV: NEW VENTURE PLANNING AND CREATION (06 Periods)**

Market research (venture opportunity screening), Feasibility analysis, Start-up capital; Sources of funding: equity financing, debt financing (loans, venture funding, angel funding), grants, gifts, bequests and financial statements, Introduction to the business plan, Preparation of business plan.

**UNIT–V: Start-Ups and Social Entrepreneurship (06 Periods)**

**Start-Ups:** Definition to start-up, Start-up activities, Promising start-ups, Venture-backed start-ups, Corporate-supported start-ups.

**Social Entrepreneurship:** Social enterprise-Need - Types - Characteristics and benefits of social enterprises, Rural entrepreneurship.

**Total Periods: 30**

**Topics for self-study are provided in the lesson plan.**

**TEXT BOOKS:**

1. Robert D. Hisrich, Mathew J. Manimala, Michael P. Peters, Dean A. Shepherd, *Entrepreneurship*, McGraw Hill Education (India) Private Limited, Eighth Edition, 2013.
2. Marc J Dollinger, *Entrepreneurship: Strategies and Resources*, Pearson, Third Edition, 2003.

**REFERENCE BOOKS:**

1. Vasant Desai, *Dynamics of Entrepreneurial Development and Management*, Himalaya Publ. House, 2004.
2. *Harvard Business Review on Entrepreneurship*, HBR Paper Back.
3. Thomas W. Zimmerer & Norman M. Scarborough, *Essential of Entrepreneurship and small business management*, PHI.

### III B.Tech. - II Semester

#### (19BT6HS02) ORGANIZATIONAL BEHAVIOR

(Common to CE, CSE, CSSE and IT)

Int. Marks	Ext. Marks	Total Marks	L	T	P	C
40	60	100	3	-	-	3

#### PRE REQUISITE:-

**COURSE DESCRIPTION:** Introduction to organizational Behavior; Individual behavior and Personality; Interpersonal and group behavior; Leadership; Organizational change and development

**COURSE OUTCOMES:** After successful completion of the course, students will be able to:

- CO1 Equip with basic idea on concepts and skills of organizational behavior.
- CO2 Demonstrate the applicability of the concept of organizational behavior to understand the behavior of people in the organization.
- CO3 Analyze the complexities associated with management of the individual, group behavior in the organization.
- CO4 Develop leadership qualities
- CO5 Improve individual behavior, skill and life-long learning in a group.

#### DETAILED SYLLABUS:

##### UNIT – I: INTRODUCTION TO ORGANIZATIONAL BEHAVIOR (9 periods)

Meaning and Definition, Nature, Scope, Features, Significance of Organizational Behavior – Levels and Contributing disciplines to OB – Emerging Issues and Challenges of OB

##### UNIT – II: INDIVIDUAL BEHAVIOR AND PERSONALITY (9 periods)

**INDIVIDUAL:** Introduction – Role of Brain and Mind in Individual Behavior – Similarities and Dissimilarities in Individuals – Reasons for individual differences – Nature of Man – Models of man – Values, Attitudes, emotions, Moods and Job satisfaction.

**PERSONALITY:** Introduction – Personality Traits – Determinants of Personality – Personality Theories.

##### UNIT – III: INTERPERSONAL AND GROUP BEHAVIOR (9 periods)

**INTRODUCTION TO INTERPERSONAL:** Process of perception – Inter personal perception

**GROUP BEHAVIOR:** Meaning and Definition of a Group – Classification of Groups – Stages of Group development.

##### UNIT – IV: LEADERSHIP (9 periods)

Meaning and Definition of Leadership – Leadership Theories: Behavioral Theories and Modern theories – Leadership Styles – New directions for leadership

##### UNIT – V: ORGANIZATIONAL CHANGE AND DEVELOPMENT (9 periods)

Meaning – Nature of work change – Pressure for change – Change Process – Types of change – Factors influencing change – Organizational development process – OD interventions/Techniques.

**Topics for Self-study are provided in the Lesson Plan**

**TEXT BOOKS:**

1. Stephen P. Robbins, Timothy A. Judge and Neharika Vohra, *Organizational Behavior*, Pearson, Noida, 16<sup>th</sup> Edition, 2017.
2. Subba Rao, P., *Management and Organizational behavior*, Himalaya Publishing House, Mumbai, Re-print 2019.

**REFERENCE BOOKS:**

1. Fred Luthans, *Organizational behavior*, McGraw Hill Higher Education, 10<sup>th</sup> Edition, 2016.
2. Shashi K. Gupta and Rosy Joshi, *Organizational Behavior*, Kalyani Publications, 8<sup>th</sup> Edition, 2017.

### III B. Tech. – II Semester

#### (19BT60101) STEEL STRUCTURES

Int. Marks	Ext. Marks	Total Marks	L	T	P	C
40	60	100	3	-	-	3

**PRE-REQUISITES:** Courses on Engineering Mechanics, Mechanics of Solids, Structural Analysis.

**COURSE DESCRIPTION:** Bolted connections; Welded connections; Beams; Tension members; Compression members; Built-up compression members; Column foundations; Roof trusses; Tubular trusses.

**COURSE OUTCOMES:** On successful completion of this course, the students will be able to:

- CO1. Design bolted and welded connections to solve complex problems associated with steel structures using appropriate techniques following relevant codes considering safety and stability besides communicating effectively in graphical form.
- CO2. Design steel beams to solve complex problems associated with steel structures using appropriate techniques following relevant codes and steel tables considering safety and serviceability besides communicating effectively in graphical form.
- CO3. Design steel tension and compression members to solve complex problems associated with steel structures using appropriate techniques following relevant codes and steel tables considering safety and stability besides communicating effectively in graphical form.
- CO4. Design steel built-up compression members and column foundations to solve complex problems associated with steel structures using appropriate techniques following relevant codes and steel tables considering safety and stability besides communicating effectively in graphical form.
- CO5. Design steel roof trusses and tubular trusses to solve complex problems associated with steel structures using appropriate techniques following relevant codes considering safety and stability besides communicating effectively in graphical form.

#### DETAILED SYLLABUS:

##### UNIT- I: BOLTED AND WELDED CONNECTIONS

(9 periods)

**Bolted Connections:** Strength and efficiency of a joint, Lap Joint, Butt joint, Eccentric connections.

**Welded Connections:** Strength of welds, Butt and fillet welds, Design of fillet welds subjected to axial load, Design of fillet welds subjected to moment acting in the plane and at right angles to the plane of the joints, Beam to beam and beam to column connections.

##### UNIT- II: BEAMS

(9 periods)

Bending, Shear and bearing strength, Design of simple beams, Design of compound beams, Design of connection of cover plates with the flanges of beams.

##### UNIT-III: TENSION AND COMPRESSION MEMBERS

(9 periods)

**Tension Members:** Net effective sectional area for angle and tee sections, Design of tension members, Lug angles.

**Compression Members:** Effective length, Radius of gyration and slenderness of compression members, Design strength, Design of axially loaded compression members.

#### **UNIT-IV: BUILT-UP COMPRESSION MEMBERS AND COLUMN FOUNDATIONS**

**(9 periods)**

**Built-up Compression Members:** Design of built-up compression members, Design of lacings and battens, Design principles of eccentrically loaded columns, Splicing of columns.

**Column Foundations:** Design of slab base and gusseted bases, Column bases subjected moment.

#### **UNIT-V: ROOF AND TUBULAR TRUSSES**

**(9 periods)**

**Roof Trusses:** Different types of trusses, Design loads, Load combinations, IS Code recommendations, Structural details, Design of simple roof trusses involving the design of purlins, members and joints.

**Tubular Trusses:** Design of tension members, compression members and connections.

**Total Periods: 45**

**Topics for self-study are provided in the lesson plan.**

#### **TEXT BOOKS:**

1. Bhavikatti, S. S., *Design of Steel Structures*, I. K. International Publishing House Pvt. Ltd., 5<sup>th</sup> Edition, 2017.
2. Ram Chandra, Virendra Gehlot, *Limit State Design of Steel Structures LSD:SS*, Scientific Publishers, 11<sup>th</sup> Edition, 2017.

#### **REFERENCE BOOKS:**

1. Subramanian, N., *Design of Steel Structures Limit State Method*, Oxford University Press, 2<sup>nd</sup> Edition, 2018.
2. Duggal, S. K., *Limit State Design of Steel Structures*, Mc.Graw Hill, 3<sup>rd</sup> Edition, 2019.
3. Ramachandra, S., *Design of Steel Structures*, Dhanpat Rai Publishing Company, 2<sup>nd</sup> Edition, 2016.
4. Punmia, B. C., Ashok Kumar Jain and Arun Kumar Jain, *Design of Steel Structures*, Laxmi Publications, 2<sup>nd</sup> Edition, 2013.

#### **ADDITIONAL LEARNING RESOURCES:**

1. Segui, W.T., *Design of Steel Structures*, Cengage Learning, 2007.
2. Alan Williams, *Steel Structures Design*, Mc Graw Hill, 2011.
3. Narayanan, R., *Teaching Resource on Structural Steel Design*, INSDAG, Ministry of Steel Publishing, 2000.
4. *Design Manual For Designing Steel Structures According to New IS: 800*, Institute for Steel Development & Growth, India.
5. *Handbook of Structural Steel Work*, BCSA and SCI.

### III B. Tech. – II Semester

#### (19BT60102) **ADVANCED STRUCTURAL ANALYSIS**

(Professional Elective - 1)

Int. Marks	Ext. Marks	Total Marks	L	T	P	C
40	60	100	3	--	--	3

**PRE-REQUISITES:** Courses on Engineering Mechanics, Mechanics of Solids, Structural Analysis

**COURSE DESCRIPTION:** Flexibility method; Stiffness method; Portal frames; Approximate method; Redundant pin-jointed frames; Two hinged arches; Three hinged arches; Cables and suspension bridges.

**COURSE OUTCOMES:** On successful completion of this course, the students will be able to:

- CO1 Analyze continuous beams to solve complex structural analysis problems using matrix methods besides communicating effectively in graphical form.
- CO2 Analyze portal frames to solve complex structural analysis problems using appropriate methods besides communicating effectively in graphical form.
- CO3 Analyze redundant pin-jointed plane trusses to solve complex advanced structural analysis problems using Castigliano's theorem besides communicating results effectively in graphical form.
- CO4 Analyze three hinged and two hinged arches to solve complex advanced structural analysis problems using appropriate techniques ensuring safety and environment.
- CO5 Analyze cables and suspension bridges to solve complex advanced structural analysis problems using appropriate techniques ensuring safety and environment.

#### **DETAILED SYLLABUS:**

##### **UNIT - I: MATRIX METHODS**

**(09 periods)**

**Flexibility Method:** Flexibility coefficients, Flexibility matrices, Application to continuous beams without and with settlement of supports.

**Stiffness Method:** Stiffness coefficients, Stiffness matrices, Application to continuous beams without and with settlement of supports.

##### **UNIT – II: PORTAL FRAMES**

**(09 Periods)**

Analysis of single bay, single storey, portal frame including side sway; Shear force and bending moment diagrams by slope deflection method, moment distribution method and Kani's method.

##### **UNIT - III: APPROXIMATE METHODS AND REDUNDANT PIN-JOINTED FRAMES**

**(09 Periods)**

**Approximate Methods:** Analysis of multi-storey frames for lateral loads using portal and cantilever methods.

**Redundant Pin-Jointed Frames:** Indeterminate frames, Static and kinematic indeterminacies, Castigliano's theorem, Analysis of pin-jointed frames up to two degrees

of internal and external indeterminacies.

#### **UNIT – IV: ARCHES**

**(09 Periods)**

**Three Hinged Arches:** Types of arches, Elastic theory of arches, Eddy's theorem, Determination of horizontal thrust, bending moment, normal thrust and radial shear; Effect of temperature.

**Two Hinged Arches:** Determination of horizontal thrust bending moment, normal thrust and radial shear; Rib shortening and temperature stresses, Tied arches, Fixed arches(No analytical question).

#### **UNIT - V: CABLES AND SUSPENSION BRIDGES**

**(09 Periods)**

Basic concepts, Suspension cables, Reactions, Tension and length of suspension cable; Effect of change in temperature, Suspension bridges with two and three stiffening girders.

**Total Periods: 45**

**Topics for self-study are provided in the lesson plan.**

#### **TEXT BOOKS:**

1. Vaidyanathan, R. and Perumal, P., *Structural Analysis- Vol. I and II*, Laxmi Publications, 4<sup>th</sup> Edition, 2016.
2. Vazirani, V. N., Ratwani, M. M. and Duggal, S. K., *Analysis of Structures- Vol. I and Vol. II*, Khanna Publications, 17<sup>th</sup> Edition, 2013.

#### **REFERENCE BOOKS:**

1. Bhavikatti S. S., *Structural Analysis – Vol. I and II*, Vikas Publishing House Pvt. Ltd., 4<sup>th</sup> Edition, 2010.
2. Thandavamoorthy, T. S., *Structural Analysis*, Oxford University Press, 5<sup>th</sup> Edition, 2011.
3. Punmia, B. C., Ashok Kumar Jain and Arun Kumar Jain, *SMTS-II –Theory of Structures*, Laxmi Publications (P) Ltd., 12<sup>th</sup> Edition, 2004.
4. Khurmi, R. S., *Theory of Structures*, S. Chand & Company Ltd., 22<sup>nd</sup> Edition, 2010.

#### **ADDITIONAL LEARNING RESOURCES:**

1. Pandit, G., Gupta, S. and Gupta, R., *Theory of Structures – Vol. II*, Tata Mc-Graw Hill Publishing Co. Ltd., 1<sup>st</sup> Edition, 1999.
2. Ramamrutham, S. and Narayanan, R., *Theory of Structures*, Dhanpat Rai Publishing Co. Ltd., 9<sup>th</sup> Edition, 2014.
3. Shah, H. J. and Junnarkar, S. B., *Mechanics of Structures – Vol. II*, Charotar Publishing House, 21<sup>st</sup> Edition, 2010.



**III B.Tech. – II Semester**  
**(19BT60103) ADVANCED SURVEYING**

(Professional Elective -1)

Int. Marks	Ext. Marks	Total Marks	L	T	P	C
40	60	100	3	-	-	3

**PRE-REQUISITES:** Courses on Matrices and Numerical Methods, Engineering Physics, Surveying.

**COURSE DESCRIPTION:** Astronomical surveying; Construction and boundary surveys; Theory of errors; Land surveys; Triangulation and baseline measurements; GPS surveying.

**COURSE OUTCOMES:** On successful completion of this course, the students will be able to:

- CO1 Analyze astronomical surveying techniques for measuring azimuth, distances, angles and coordinates to solve complex surveying problems using appropriate tools and techniques by following ethics and considering society, environment besides communicating effectively in graphical form.
- CO2 Analyze construction and boundary surveys to solve complex surveying problems using appropriate tools and techniques by following ethics and considering society, environment besides communicating effectively in graphical form.
- CO3 Analyze errors in surveying to solve complex surveying problems using appropriate tools and techniques by following ethics and considering society, environment besides communicating effectively in graphical form.
- CO4 Develop layouts of land surveys to solve complex surveying problems using appropriate tools and techniques by following ethics and considering, society and environment besides communicating effectively in graphical form.
- CO5 Analyze triangulation and baseline measurements to solve complex surveying problems using appropriate tools and techniques by following ethics and considering society, environment besides communicating effectively in graphical form.
- CO6 Analyze GPS surveying to solve complex surveying problems using appropriate tools and techniques by following ethics and through continuous learning considering society by ensuring environment and sustainability besides communicating effectively in graphical form.

**DETAILED SYLLABUS:**

**UNIT - I: ASTRONOMICAL SURVEYING (08 Periods)**

Astronomical coordinate systems, Terrestrial coordinate systems, Astronomical triangle, Determination of azimuth, Determination of latitude and longitude, Time correlations.

**UNIT - II: CONSTRUCTION AND BOUNDARY SURVEYS (10 Periods)**

**Construction Surveys:** Specialized equipment for construction surveys, Staking out pipe line, Staking out buildings, Staking out highways, Construction surveys using total station and GNSS equipment, Sources of errors and mistakes in construction surveys.

**Boundary Surveys:** Categories of land surveys, Property description - By metes and bounds, By block and lot system and by coordinates; Retracement surveys, Partitioning land, Sources of errors and mistakes in boundary surveys.

**UNIT -III: THEORY OF ERRORS AND LAND SURVEYS (09 Periods)**

**Theory of Errors:** Types and sources of errors, Loss of accidental errors, Loss of weights, Theory of least squares, Method of weights, Method of correlates, Angle and station adjustment, Figure adjustment.

**Land Surveys:** Layouts, Measurements

**UNIT - IV: TRIANGULATION AND BASELINE MEASUREMENTS (9 Periods)**

Principle and classification of triangulation systems, Selection of base line and stations, Orders of triangulation, Station marks, Signals, Towers, Baseline measurement - Rigid bars, Flexible apparatus, Problems; Satellite station and reduction to centre.

**UNIT - V: GPS SURVEYING (09 Periods)**

Principles of GPS surveying and methods, Components of GPS-Space segment, Receiver segment, User segment; Errors in observations and corrections, Mapping with GPS, Application of GPS, Advantages over conventional methods, DGPS, Latest advancements in GPS surveying.

**Total Periods: 45**

**Topics for self-study are provided in lesson plan.**

**TEXT BOOKS:**

1. Arora, K. R., *Surveying – Vol. III*, Standard Book House, 12<sup>th</sup> Edition, 2015.
2. Ghilani, C.D., *Elementary Surveying-An Introduction to Geomatics*, Pearson India Education Services Pvt. Ltd, 13<sup>th</sup> Edition, 2018.
3. Chandra, A. M., *Higher Surveying*, New Age International (P) Limited Publishers, 3<sup>rd</sup> Edition, 2015.

**REFERENCE BOOKS:**

1. Duggal, S. K., *Surveying – Vol. I and II*, Tata McGraw–Hill Publishing Co. Ltd., 5<sup>th</sup> Edition, 2019.
2. Benton, A. R., and Taety, P. J., *Elements of Plane Surveying*, McGraw Hill, 3<sup>rd</sup> Edition, 2010.
3. Punimia, B. C., Ashok Jain, K and Jain, A.K., *Surveying – Vol. II*, Laxmi Publications (P) Ltd, 16<sup>th</sup> Edition, 2016.
4. Kanetkar, T. P and Kulakarni, S. V., *Surveying and Leveling*, Vidyarthi Griha Prakasham, 24<sup>th</sup> Edition, 2013.

**ADDITIONAL LEARNING RESOURCES:**

1. Venkatramaih, C., *Textbook of Surveying*, Universities Press (India) Limited, Hyderabad, 2<sup>nd</sup> Edition, 2011.
2. Parkinson, B. W., Spilker, J. J., *Global Positioning System: Theory and Applications, Volume 1*, American Institute of Aeronautics and Astronautics, 1996.
3. Nathanson, J. A., Lanzafama, M.T and Philip Kissam, *Surveying Fundamentals and Practices*, Pearson Publications, 7<sup>th</sup> Edition, 2017.
4. Sickle, J.V., *GPS for Land Surveyors*, CRC Press, 4<sup>th</sup> Edition, 2015.

### III B.Tech. - II Semester

#### (19BT60104) AIR AND NOISE POLLUTION AND CONTROL

(Professional Elective - 1)

Int. Marks	Ext. Marks	Total Marks	L	T	P	C
40	60	100	3	-	-	3

**PRE-REQUISITES:** Course on Environmental Science

**COURSE DESCRIPTION:** Air and noise pollution; Effects of air and noise pollution; Sampling and analysis; Control methods and equipment; Air and noise pollution from industrial operations.

**COURSE OUTCOMES:** On successful completion of this course, the students will be able to:

- CO1 Analyze air and noise pollution to solve complex environmental problems using appropriate tools and techniques considering society, health and environment besides communicating effectively in graphical form.
- CO2 Analyze the effects of air and noise pollution to solve environmental problems considering society, health, environment and economics besides communicating effectively in graphical form.
- CO3 Analyze air and noise sampling techniques to solve complex environmental problems using appropriate tools following relevant standards, codes and latest developments considering society, health and environment besides communicating effectively in graphical form.
- CO4 Analyze the air and noise pollution control methods and equipment to solve complex environmental problems following relevant standards and codes considering society, health, environment and economics besides communicating effectively in graphical form.
- CO5 Analyze the air and noise pollution from industrial operations to solve complex environmental problems following relevant standards, codes and regulations considering society, health, environment besides communicating effectively in graphical form.

#### DETAILED SYLLABUS:

##### UNIT – I: AIR AND NOISE POLLUTION (08 Periods)

Scope and significance of air pollution, Episodes in India and other nations – Overview; Sources and classification of air pollutants, Meteorology and air pollution – Plume behavior, Wind rose; Dispersion theories and model, Stack height; Scope and significance of noise pollution.

##### UNIT – II: EFFECTS OF AIR AND NOISE POLLUTION (09 Periods)

Effects of air pollution on human health, animals and plants; Global effects of air pollution – Green house effect, Heat islands, Acid rains, Ozone holes; Economic effects of air pollution – Material damage; Art treasures in India and other countries; Effects of noise pollution on human health.

##### UNIT – III: SAMPLING AND ANALYSIS (09 Periods)

Classification, Stages and methods of sampling, Difficulties encountered, Instruments of sampling, Duration and location of sampling sites, Sampling - High volume filtration, Stack sampling techniques; Recent trends in sampling of stack emissions; Noise measurement methods and analysis.

##### UNIT – IV: CONTROL METHODS AND EQUIPMENT (10 Periods)

Analytical methods – Chemical, Instrumental and biological methods; Types of collection equipment – Settling chambers, Inertial separators, Cyclones, Bag Filters, Electrostatic precipitators, Scrubbers; Choice of equipment and economical aspects, Control of smoke, Gaseous contaminants, Odours and by process changes; Noise control methods and equipment.

#### **UNIT – V: AIR AND NOISE POLLUTION FROM INDUSTRIAL OPERATIONS**

**(09 Periods)**

***Air Pollution from Industrial Operations:*** Air pollution from major industrial operations – Mining, Cement industry, Petroleum refineries, Ferrous and non-ferrous metallurgical operations, Thermal power plants; National ambient air quality standards; Emission standards and air pollution indices.

***Noise Pollution from Industrial Operations:*** Noise pollution from industrial operations and permitted noise levels as per the regulatory authority.

**Total Periods: 45**

***Topics for self-study are provided in the lesson plan.***

#### **TEXT BOOKS:**

1. Rao, M. N. and Rao, H. V. N., *Air Pollution*, Tata McGraw- Hill Education Pvt. Ltd., New Delhi, 19<sup>th</sup> Edition, 2010.
2. Thod Godish, *Air Quality*, Levis Publishers, Taylor and Francis Group, New Delhi, 4<sup>th</sup> Edition, 2003.
3. Wark, K. and Warner, C. F., Harper and Row, *Air Pollution: Its Origin and Control*, Addison–Wesley, New York, 3<sup>rd</sup> Edition, 1998.

#### **REFERENCES:**

1. Trivedy, R. K. and Goel, P. K., *An Introduction to Air Pollution*, B. S. P. Books Pvt. Ltd., Hyderabad, 2<sup>nd</sup> Edition, 2005.
2. Crawford, M., *Air pollution Control Theory*, Tata McGraw-Hill, New Delhi, 1980.
3. Perkins, H. C., *Air Pollution*, McGraw Hill Higher Education, Lincoln, United Kingdom, 1974.
4. Dara, S.S. and Mishra, D.D., *A Textbook of Environmental Chemistry and Pollution Control*, S. Chand Publishing, New Delhi, 2006.

#### **ADDITIONAL LEARNING RESOURCES:**

1. Murali Krishna, K. V. S. G., *Air Pollution and Control*, Kousal and Co. Publications, New Delhi, 3<sup>rd</sup> Edition, 2008.
2. Padmanabha Murthy, B., *Environmental Meteorology*, I. K. Internationals Publishing House Pvt. Ltd., New Delhi, 2009.

### III B.Tech. - II Semester

#### (19BT60105) ARCHITECTURE AND TOWN PLANNING

(Program Elective – 1)

Int. Marks	Ext. Marks	Total Marks	L	T	P	C
40	60	100	3	-	-	3

**PRE-REQUISITES:** Course on Construction, Planning and Project Management

**COURSE DESCRIPTION:** Architectural design and site planning; Building architecture and services; Town planning and structure; Land use planning; Regional planning and standards.

**COURSE OUTCOMES:** On successful completion of this course, the students will be able to:

- CO1. Analyze architectural design and site planning to solve architectural problems using appropriate tools and techniques following relevant standards and regulations considering society, environment and sustainability.
- CO2. Design the building architecture and services to solve complex architectural problems using appropriate tools and techniques following relevant standards, codes and regulations considering safety, environment and sustainability besides communicating effectively in graphical form.
- CO3. Analyze town planning and structure to solve urban development problems using appropriate tools and techniques following relevant policies considering society, environment and sustainability.
- CO4. Analyze land use planning to solve complex urban development problems using appropriate techniques following relevant policies considering society, environment and sustainability besides communicating effectively in graphical form.
- CO5. Analyze regional planning to solve complex urban and regional problems using appropriate techniques following relevant standards considering society, environment and sustainability besides communicating effectively in graphical form.

#### **DETAILED SYLLABUS:**

##### **UNIT – I: ARCHITECTURAL DESIGN AND SITE PLANNING (09 Periods)**

Architectural design, analysis, integration of function and aesthetics; Introduction to basic elements and principles of design, Surveys, Site analysis, Development control, Layout regulations, Layout design concepts.

##### **UNIT – II: BUILDING ARCHITECTURE AND SERVICES (09 Periods)**

Residential, Institutional, Commercial and industrial, Application of anthropometry and space standards, Inter relationships of functions, Safety standards, Building rules and regulations, National building code, Integration of building services, Interior design, Man and environment interaction, Factors that determine climate, Characteristics of climate types, Design for various climate types, Passive and active energy controls, Green building concept.

##### **UNIT – III: TOWN PLANNING AND STRUCTURE (09 Periods)**

Planning concepts and processes, Objectives, Levels of planning in India and their interrelationship, Planning administration, Models of planning processes, Components of

settlement structures, Models of urban structure; Demand and supply of land for urban use, Means and mechanism, Impact on urban structure, Goals of land policy.

#### **UNIT – IV: LAND USE PLANNING**

**(09 Periods)**

Concept of land use, Locational attributes of land use, Land use planning information system, Activity system and choice of space qualities, System approach and physical planning, Approach to land use planning, Introduction to spatial planning at regional level, Choice theory and advocacy planning and their application action plan and its relevance, Development plan types, Scope and objectives, Principles of landscape design.

#### **UNIT – V: REGIONAL PLANNING AND STANDARDS**

**(09 Periods)**

Planning practices in India, Method of identifying urban and regional problem, Setting of goals objectives and priorities, Performance standards, Spatial standards and standard for utilities, Classification of regions, Regionalization and delineation techniques for various types of regions, Cluster and factor analysis method.

**Total Periods: 45**

***Topics for self-study are provided in the lesson plan.***

#### **TEXT BOOKS:**

1. Biswas Hiranmay, Principles of Town Planning and Architecture, Vayu Education of India, 2nd Edition, 2019.
2. Satish Chandra Agarwala, Architecture and Town Planning, Dhanpat Rai and Company, 2008.

#### **REFERENCE BOOKS:**

1. Pratap Rao, M., *Urban Planning Theory and Practice*, CBS Publishers & Distributors Pvt. Ltd., New Delhi, 1<sup>st</sup> Edition, 2019.
2. Hiraskar, G. K., *Fundamentals of Town Planning*, Dhanpat Rai & Sons, 2018.
3. Rangwala, S. C., *Town Planning*, Charotar Publishing House, 31<sup>st</sup> Edition, 2021.
4. Muthu Shoba Mohan, G., *Principles of Architecture*, Oxford University Press, New Delhi, 1<sup>st</sup> Edition, 2006.
5. Bandopadhyay, A., *Text Book of Town Planning*, Books and Allied, 2018.

#### **ADDITIONAL LEARNING RESOURCES**

1. Kulshrestha S.K., *Dictionary of Urban and Regional Planning*, Kalpaz Publications, New Delhi, 2006.
2. Faludi, Andreas, *Planning Theory*, Pergamon Press, 1973.

### III B.Tech. – II Semester

#### (19BT60106) **GROUND IMPROVEMENT TECHNIQUES**

(Professional Elective – 1)

Int. Marks	Ext. Marks	Total Marks	L	T	P	C
40	60	100	3	-	-	3

**PREREQUISITES:** Courses on Soil Mechanics and Foundation Engineering.

**COURSE DESCRIPTION:** Scope of ground improvement; Methods of ground improvement; Drainage and dewatering; In-situ densification of granular soils and cohesive soils; Soil stabilization; Geosynthetics and Earth Reinforcement.

**COURSE OUTCOMES:** On successful completion of this course, the students will be able to:

- CO1 Analyze ground improvement techniques to solve complex ground engineering problems through continuous learning considering safety, environment and sustainability besides communicating effectively in graphical form.
- CO2 Analyze drainage and dewatering techniques to solve complex ground engineering problems considering safety, environment and sustainability besides communicating effectively in graphical form.
- CO3 Analyze in-situ densification techniques of granular soils and cohesive soils to solve complex ground engineering problems by following the relevant codes of practice and ensuring safety, environment and sustainability besides communicating effectively in graphical form.
- CO4 Analyze soil stabilization techniques to solve complex ground engineering problems by following the relevant codes of practice and ensuring safety, environment and sustainability besides communicating effectively in graphical form.
- CO5 Analyze geosynthetics and earth reinforcement techniques to solve ground engineering problems through continuous learning considering safety, environment and sustainability besides communicating effectively in graphical form.
- CO6 Design geosynthetic reinforced earth walls to solve complex stability problems associated with earth retaining structures using appropriate techniques and following relevant codes considering society, environment and sustainability besides communicating effectively in graphical form.

#### **DETAILED SYLLABUS:**

##### **UNIT – I: GROUND IMPROVEMENT**

**(08 Periods)**

Role of ground improvement in foundation engineering, Methods of ground improvement, Geotechnical problems in alluvial, laterite and black cotton soils; Selection of suitable ground improvement techniques based on soil condition; Latest Methods.

##### **UNIT – II: DRAINAGE AND DEWATERING**

**(09 Periods)**

Drainage techniques, Well points, Vacuum and electroosmotic methods, Dewatering after construction, Control of surface water, Well pointing in deep excavation, Drainage on slopes, Electro kinetic dewatering system.

### **UNIT – III: IN-SITU DENSIFICATION OF GRANULAR SOILS AND COHESIVE SOILS (10 Periods)**

**Granular Soils:** Principles of in-situ densification, In-situ densification methods – Dynamic compaction, Blasting, Vibro compaction, Granular piles, Relative merits and their limitations.

**Cohesive Soils:** Principles of in-situ densification, In-situ densification methods – Vertical drains, Sand wick, Geodrains, Stone columns, Granular pile anchors, Lime columns and thermal methods, Relative merits and their limitations.

### **UNIT – IV: SOIL STABILIZATION (09 Periods)**

Soil Stabilization – Mechanical, Bitumen, Cement, Lime, Fly ash and Chemical; Stabilization of expansive soils; Soil stabilization by grouting - Types of grouts, Grouting equipment and machinery, Injection methods, Grout monitoring; Shotcreting and guniting technology.

### **UNIT – V: GEOSYNTHETICS AND EARTH REINFORCEMENT (09 Periods)**

Concept of reinforcement, Types of reinforcement material, Components and applications of reinforced earth, Soil nailing, Geosynthetics – Types, Functions, Applications; Design of geosynthetic reinforced earth walls; Latest developments in earth reinforcement techniques.

**Total Periods: 45**

**Topics for self-study are provided in the lesson plan.**

#### **TEXT BOOKS:**

1. Hausmann, M. R., *Engineering Principles of Ground Modification*, McGraw–Hill Publishers, 2013.
2. Purushotham Raj, P., *Ground Improvement Techniques*, Laxmi Publications Pvt. Ltd., 2<sup>nd</sup> edition, 2016.

#### **REFERENCE BOOKS:**

1. Moseley, M. P. and Kirsch. K., *Ground Improvement*, Taylor Francis Ltd., 2<sup>nd</sup> Revised Edition, 2004.
2. Xanthakos P. P., Abramson, L. W and Bruce, D. A., *Ground Control and Improvement*, John Wiley and Sons, 1994.
3. Koerner, R. M., *Designing with Geosynthetics*, Xlibris Publishers, 6<sup>th</sup> Edition, 2012.
4. Jewell, R. A., *Soil Reinforcement with Geotextiles (Report)*, CIRIA Special Publication, 1996.

#### **ADDITIONAL LEARNING RESOURCES:**

1. Chattopadhyay, B. C. and Maity, J., *Ground Improvement Techniques*, PHI Learning, 2017.
2. Han, J., *Principles and Practice of Ground Improvement*, John Wiley, 2015.
3. Siva Kumar Babu, G. L., *An Introduction to Soil Reinforcement & Geosynthetics*, Universities Press, 2005.

#### **IS CODES:**

IS 13094 – 1992 : Selection of Ground Improvement Techniques for Foundations in Weak Soils.

IS 15284 (Part 2)- 2004 : Design and Construction for Ground Improvement.



### III B.Tech. – II Semester

#### (19BT60107) URBAN STORMWATER MANAGEMENT

(Professional Elective–1)

Int. Marks	Ext. Marks	Total Marks	L	T	P	C
40	60	100	3	0	-	3

**PRE-REQUISITES:** Course on Engineering Hydrology, Fluid Mechanics.

**COURSE DESCRIPTION:** Concept of Urban hydrology, Rainfall analysis for urban stormwater design, Rainfall abstraction, Urban stormwater analysis and management and Overview of urban stormwater models.

**COURSE OUTCOMES:** On successful completion of this course, the students will be able to:

- CO1. Analyze urban hydrological cycle for estimating stormwater runoff considering latest developments, society, environment, and sustainability besides communicating effectively in graphical form.
- CO2. Analyze rainfall data for solving complex urban drainage problems using different techniques considering latest developments, relevant guidelines, society, environment and sustain ability besides communicating effectively in graphical form.
- CO3. Analyze abstractions losses from urban catchments for solving for solving complex urban hydrology problems using different tools and techniques considering latest developments, relevant guidelines, environment and sustainability besides communicating effectively in graphical form.
- CO4. Design synthetic hydrographs for solving complex urban stormwater drainage problems using different tools and techniques considering latest developments, relevant guidelines, safety, environment, sustainability and management besides communicating effectively in graphical form.
- CO5. Design urban drainage networks for solving complex urban stormwater drainage problems using different tools and techniques considering latest developments, relevant guidelines, safety, environment and sustainability besides communicating effectively in graphical form.

#### **DETAILED SYLLABUS:**

##### **UNIT - I: URBAN HYDROLOGY**

**(09 Periods)**

Urban hydrological cycle, Urban water resources – Major problems, Historical perspective; Effects of urbanization on catchment hydrology, Interaction of land use and urban stormwater runoff, Need for urban drainage system.

##### **UNIT - II: RAINFALL ANALYSIS FOR URBAN STORMWATER DESIGN(09 Periods)**

Rainfall data, Depth-duration-rainfall analysis, Areal effect of point rainfall, Design rainfall duration, Time distribution of design rainfall, examples of design rainfall development.

##### **UNIT - III: RAINFALL ABSTRACTION**

**(10 Periods)**

Introduction, Interception, Detention and retention concepts, Depression storage, Infiltration, SCS method, The  $\Phi$ -Index, Importance of losses in urbanized basins, Open channel flows in urban watersheds.

#### **UNIT - IV: URBAN STORMWATER ANALYSIS AND MANAGEMENT (09 Periods)**

Rational method, SCS composite hydrograph method, time of concentration, Synthetic unit hydrograph method, urban runoff processes, Hydraulic analysis and design guidelines, Flow and storage capacity of urban components, Temple tanks, Social awareness and involvement.

#### **UNIT - V: OVERVIEW OF URBAN STORMWATER MODELS (08 Periods)**

Introduction, Structural and nonstructural control measures, Types of models, Role of urban stormwater models and levels of analysis, Storm water management model (SWMM), Case studies.

**Total Periods: 45**

***Topics for self-study are provided in the lesson plan.***

#### **TEXT BOOKS:**

1. Hall, M.J., *Urban Hydrology*, Elsevier Applied Science Publishers, 1<sup>st</sup> Edition, 1984.
2. David, F. K., *Urban Stormwater Hydrology (Water Resources Monograph)*, American Geophysical Union, 4<sup>th</sup> Edition, 1991.

#### **REFERENCE BOOKS:**

1. David, B., Christopher, J. D., Christos, M. and John, W. D, *Urban Drainage*, CRC Press, 4<sup>th</sup> Edition, 2018.
2. Osman, A. A. and Houghtalen, R. J., *Urban Hydrology, Hydraulics, and Stormwater Quality: Engineering Applications and Computer Modeling*, Wiley Publications, 1<sup>st</sup> Edition, 2003.
3. Overtens, D.E. and Meadows, M.E., *Storm Water Modelling*, Academic Press, New York, 1<sup>st</sup> Edition, 1976.
4. Wanielista, M.P. and Yousef, Y.A., *Stormwater Management*, John Wiley and Sons, Inc., New York, 1993.

#### **ADDITIONAL LEARNING RESOURCES:**

1. Oke, T. R., *Urban Climates*, Cambridge University Press.
2. Vieux, B. E., *Distributed Hydrologic Modeling Using GIS*, Springer Nature.
3. Singh, V. P., *Computer Models of Watershed Hydrology*, Water Resources Publications.

### III B. Tech. – II Semester

#### (19BT60108) RAILWAY ENGINEERING

(Professional Elective-1)

Int. Marks	Ext. Marks	Total Marks	L	T	P	C
40	60	100	3	--	--	3

**PRE-REQUISITES:** Course on Transportation Engineering.

**COURSE DESCRIPTION:** Railways in India and alignment of railway lines; Permanent way; Geometric design of railway tracks; Points and Crossings; Rolling stock; Railway stations and yards; Signalling and interlocking; Maintenance of railway track.

**COURSE OUTCOMES:** On successful completion of this course, the students will be able to:

- CO1 Analyze Indian railways and alignment of railway lines considering society and environment besides communicating effectively in graphical form.
- CO2 Analyze various components of permanent way to solve railway engineering problems using appropriate tools and techniques following relevant guidelines considering society and environment besides communicating effectively in graphical form.
- CO3 Design the geometric features of a railway track and tongue rail to solve complex railway engineering problems using appropriate techniques and following relevant guidelines considering society, environment and sustainability besides communicating effectively in graphical form.
- CO4 Analyze various components of points and crossings in a railway track to solve railway engineering problems using appropriate tools and techniques following relevant standards considering safety besides communicating effectively in graphical form.
- CO5 Analyze rolling stock, layouts of railway stations and yards following relevant guidelines considering safety besides communicating effectively in graphical form.
- CO6 Analyze signaling, interlocking and maintenance of railway track to solve railway engineering problems using appropriate tools and techniques following relevant specifications considering safety besides communicating effectively in graphical form.

#### DETAILED SYLLABUS:

##### UNIT – I: RAILWAYS IN INDIA AND ALIGNMENT OF RAILWAY LINES (9 Periods)

**Railways in India:** Role of Indian Railways in national development, Classification of railway lines in India.

**Alignment of Railway Lines:** Importance of good alignment, Basic requirements of an ideal alignment, Selection of a good alignment.

##### UNIT-II: PERMANENT WAY AND GEOMETRIC DESIGN (11 Periods)

**Permanent Way:** Components and their functions, Rails – Functions and types, Rail fastenings; Concept of gauges, Coning of wheels, Creep; Sleepers – Functions and requirements, Sleeper density and spacing types, Methods of fixing rails with pre-stressed concrete and wooden sleepers; Ballast – functions, types, sizes.

**Geometric Design of Railway Tracks:** Necessity for geometric design, Gradients, Grade compensation on curves; Curves – Circular, Transition, Compound and reverse; Superelevation.

**UNIT - III: POINTS AND CROSSINGS****(8 Periods)**

Switches – Types, Switch angle, Flangeway clearance, Heel divergence, Throw of the switch; Tongue rails – design; Crossings – types; Turnouts – types.

**UNIT-IV: ROLLING STOCK, RAILWAY STATIONS AND YARDS****(8 Periods)**

Re-laying of track, Layouts of railway stations and yards, Rolling stock, Tractive power, Track resistance, Level crossings.

**UNIT-V: SIGNALING, INTERLOCKING AND MAINTENANCE OF RAILWAY TRACK****(9 Periods)**

**Signalling and Interlocking:** Signalling, Interlocking and track circuiting - Construction and maintenance.

**Maintenance of Railway Track:** Maintenance program - Monsoon, pre monsoon, post monsoon maintenance; Causes for maintenance, Tools for railway track maintenance and their functions, Surface defects and their remedial measures.

**Total Periods: 45**

**Topics for self-study are provided in the lesson plan.**

**TEXT BOOKS:**

1. Chandra, S. and Agarwal, M. M., *Railway Engineering*, Oxford University Press, New Delhi, India, 2<sup>nd</sup> Edition, 2013.
2. Saxena, S. C. and Arora, S. P., *A Text book of Railway Engineering*, Dhanpat Rai Publications, 2010.

**REFERENCE BOOKS:**

1. Jotin Khisty, C. and Kent Lall, B., *Transportation Engineering – An Introduction*, Prentice Hall of India Pvt. Ltd., 3<sup>rd</sup> Edition, 2016.
2. Partha Chakroborthy and Animesh Das, *Principles of Transportation Engineering*, Prentice Hall of India Pvt. Ltd., 2005.
3. Papacostas, C. S. and Prevedouros, P. D., *Transportation Engineering and Planning*, PearsonIN, 3<sup>rd</sup> Edition, 2015.
4. Mannering, F. L. and Washburn, S. S., *Principles of Highway Engineering and Traffic Analysis*, John Wiley & Sons, Inc., 5<sup>th</sup> Edition, 2013.

**ADDITIONAL LEARNING RESOURCES:**

1. Rangwala, S. C., *Railway Engineering*, Charotar Publishing House Pvt. Ltd., 27<sup>th</sup> Edition, 2017.
2. *Indian Railways Code for Engineering Department*, 4<sup>th</sup> Edition, 2012.
3. *A hand book for DO's and DON'Ts on Points & Crossings* by Government of India, Ministry of Railways.

### III B. Tech. – II Semester

#### (19BT60109) **ADVANCED REINFORCED CEMENT CONCRETE STRUCTURES**

(Professional Elective – 2)

Int. Marks	Ext. Marks	Total Marks	L	T	P	C
40	60	100	3	--	--	3

**PRE-REQUISITES:** Courses on Civil Engineering Materials and Concrete Technology, Engineering Mechanics, Mechanics of Solids, Structural Analysis, Reinforced Cement Concrete Structures.

**COURSE DESCRIPTION:** Advanced reinforced cement concrete structures: Foundations; Flat slabs; Retaining walls; Water tanks; Bunkers; Silos; Chimneys.

**COURSE OUTCOMES:** On successful completion of this course, the students will be able to:

- CO1. Design foundations to solve complex problems related to reinforced cement concrete structures using appropriate methods and relevant codes of practice ensuring safety and serviceability besides communicating effectively through schematic detailing.
- CO2. Design flat slabs to solve complex problems related to reinforced cement concrete structures using appropriate methods and relevant codes of practice ensuring safety and serviceability besides communicating effectively through schematic detailing.
- CO3. Design retaining walls to solve complex problems related to reinforced cement concrete structures using appropriate methods and relevant codes of practice ensuring safety and serviceability besides communicating effectively through schematic detailing.
- CO4. Design water tanks to solve complex problems related to reinforced cement concrete structures using appropriate methods and relevant codes of practice ensuring safety and serviceability besides communicating effectively through schematic detailing.
- CO5. Design bunkers, silos and chimneys to solve complex problems related to reinforced cement concrete structures using appropriate methods and relevant codes of practice ensuring safety and serviceability besides communicating effectively through schematic detailing.

#### **DETAILED SYLLABUS:**

##### **UNIT - I: FOUNDATIONS (10 Periods)**

Design of Strap Footings; Raft Foundations; Pile Foundations; Pile Cap.

##### **UNIT - II: FLAT SLABS (08 Periods)**

Properties of flat slabs, Behaviour of flat slab, Shear in flat slabs, Design of flat slabs.

##### **UNIT - III: RETAINING WALLS (09Periods)**

Lateral earth pressure, Design of cantilever and counterfort retaining walls.

##### **UNIT - IV: WATER TANKS (09 Periods)**

Types of water tanks, IS code provisions, Design of water tanks with flexible base and rigid base.

## UNIT - V: MISCELLANEOUS STRUCTURES

(09 Periods)

Design of Bunkers, Silos, Chimneys.

**Total Periods: 45**

**Topics for self-study are provided in the lesson plan.**

### TEXT BOOKS:

1. Syal, I.C., Goel, A.K., *Reinforced Concrete Structures*, S. Chand & Company Ltd., 4<sup>th</sup> Edition, 2010.
2. Krishna Raju, *Advanced Reinforced Concrete Design*, CBS Publishers and Distributors, 3<sup>rd</sup> Edition 2016.

### REFERENCE BOOKS:

1. Roy, S. K. and Sinha, N. C., *Fundamentals of Reinforced Concrete*, S. Chand & Company Ltd., 5<sup>th</sup> Edition, 2013.
2. Varghese, P. C., *Limit State Design of Reinforced Concrete*, Prentice Hall of India, 2<sup>nd</sup> Edition, 2010.
3. Punmia, B. C., Ashok Kumar Jain and Arun Kumar Jain, *Reinforced Concrete Structures – Vol. I*, Laxmi Publications Pvt. Ltd., 7<sup>th</sup> Edition, 2013.
4. Gambhir, M. L., *Fundamentals of Reinforced Concrete Design*, Printice Hall of India Pvt. Ltd., 2011.

### ADDITIONAL LEARNING RESOURCES:

1. Park and Paulay, *Reinforced Concrete Structures*, Willey Publishers, 1975.
2. Arthus H. Nilson, David Darwin, and Chorles W. Dolar, *Design of Concrete Structures*, Tata Mc. Graw-Hill, 13<sup>th</sup> Edition, 2005.
3. Karve, S.R., Shah, V.L., *Limit State Theory and Design of Reinforced Concrete*, Standard Publishers, Pune, 3<sup>rd</sup> Edition, 1994.
4. Krishna Raju, N. and Pranesh, R. N., *Reinforced Concrete Design*, CBS Publishers Distributors, 1<sup>st</sup> Edition, 2018.
5. Unnikrishna Pillai, S., Devdas Menon, *Reinforced Concrete Design*, Tata Mc. Graw Hill, 3<sup>rd</sup> Edition, 2010.
6. Sargis S. Safarian, Ernest C Harris, *Design and Construction of Silos and Bunkers*, Van Nostrand Reinhold, 1985

### Codes:

IS 456 - 200	: Plain and Reinforced Concrete – Code of Practice
SP 16 - 1980	: Design Aids for Reinforced Concrete to IS 456
IS 1904 - 1988	: Design and Construction of Foundations in Soils:
IS 2950 - 1981	: Design and Construction of Foundations
IS 3370 - 2009	: Concrete Structures for Storage of Liquids
IS: 4995 - 1974	: Design of Reinforced Concrete Bins for the Storage of Granular and Powdery Materials
IS: 875 – 1987	: Design loads for Buildings and Structures
IS 1649 - 1962	: Design and Construction of Flues and Chimneys for Domestic Heating Appliances
IS 4998 - 1992	: Design of Reinforced Concrete Chimneys

### III B.Tech. – II Semester

#### (19BT60110) GEOENVIRONMENTAL ENGINEERING

(Professional Elective -2)

Int. Marks	Ext. Marks	Total Marks	L	T	P	C
40	60	100	3	-	-	3

**PRE-REQUISITES:** Courses on Soil Mechanics and Environmental Engineering.

**COURSE DESCRIPTION:** Fundamentals of geoenvironmental engineering; Soil–water–contaminant interaction; Waste containment system; Contaminant site remediation; Advanced soil characterization.

**COURSE OUTCOMES:** On successful completion of this course, the students will be able to:

- CO1 Analyze geoenvironmental properties of soil to solve complex problems of geoenvironmental engineering through continuous learning by ensuring safety, environment and sustainability besides communicating effectively in graphical form.
- CO2 Analyze soil-water-contaminant interaction to solve complex geoenvironmental engineering problems using appropriate tools and techniques ensuring safety, environment and sustainability besides communicating effectively in graphical form.
- CO3 Design waste containment systems to solve complex geoenvironmental engineering problems using appropriate tools and techniques by following the relevant codes of practice and ensuring cost effectiveness, safety, environment and sustainability besides communicating effectively in graphical form.
- CO4 Analyze contaminated site characterization and remediation to solve complex geoenvironmental engineering problems using appropriate tools and techniques by following the relevant codes of practice and ensuring safety, environment and sustainability besides communicating effectively in graphical form.
- CO5 Analyze advanced soil characterization techniques to solve complex problems of geoenvironmental engineering by following the relevant codes of practice and through continuous learning by ensuring safety, environment and sustainability besides communicating effectively in graphical form.

#### **DETAILED SYLLABUS:**

##### **UNIT - I: FUNDAMENTALS OF GEOENVIRONMENTAL ENGINEERING(09 Periods)**

Scope of geoenvironmental engineering, Multiphase behavior of soil, Role of soil in geoenvironmental applications; Importance of soil physics, soil chemistry, hydrogeology and biological process; Sources and type of ground contamination, Impact of ground contamination on geoenvironmental, Case histories on geoenvironmental problems.

##### **UNIT - II: SOIL - WATER – CONTAMINANT INTERACTION (09 Periods)**

Soil mineralogy characterization and its significance in determining soil behavior, Soil–water interaction and concepts of double layer, Forces of interaction between soil particles, Concepts of unsaturated soil, Importance of unsaturated soil in geoenvironmental problems, Measurement of soil suction, Water retention curves, Water flow in saturated and unsaturated zone, Soil–water–contaminant interactions and its implications, Factors affecting retention and transport of contaminants.

##### **UNIT - III: WASTE CONTAINMENT SYSTEM (09 Periods)**

Evolution of waste containment facilities and disposal practices, Site selection based on environmental impact assessment, Different roles of soil in waste containment, Different components of waste containment system and its stability issues, Property

evaluation for checking soil suitability for waste containment, Design of waste containment facilities.

**UNIT - IV: CONTAMINANT SITE REMEDIATION (09 Periods)**

Site characterization, Risk assessment of contaminated site, Soil remediation technologies– Soil vapour extraction, Soil washing, Stabilization/solidification, Electrokinetic remediation, Thermal desorption, Vitrification, Bioremediation Phytoremediation; Groundwater remediation technologies – Pump and treat, In-situ flushing, Permeable reactive barriers, In-situ air sparging, Monitored natural attenuation, Bioremediation; Selection and planning of remediation technologies, Some examples of in-situ remediation.

**UNIT - V: ADVANCED SOIL CHARACTERIZATION (09 Periods)**

Contaminant analysis, Water content and permeability measurements, Electrical and thermal property evaluation, Use of GPR for site evaluation, Introduction to geotechnical centrifuge modeling, Characterization of contaminated soils by using latest techniques.

**Total Periods: 45**

**Topics for self-study are provided in the lesson plan.**

**TEXT BOOKS:**

1. Reddi, L. N. and Inyang, H. I., *Geoenvironmental Engineering Principles and Applications*, Marcel Dekker Inc, 1<sup>st</sup> Edition, 2000.
2. Sharma, H. D. and Reddy, K. R., *Geoenvironmental Engineering: Site Remediation, Waste Containment, and Emerging Waste Management Technologies*, John Wiley & Sons, Inc., USA, 1<sup>st</sup> Edition, 2004.

**REFERENCE BOOKS:**

1. Rowe, R. K., *Geotechnical and Geoenvironmental Engineering Handbook*, Kluwer Academic, 1<sup>st</sup> Edition, 2001.
2. Yong, R. N., *Geoenvironmental Engineering, Contaminated Soils, Pollutant Fate, and Mitigation*, CRC Press, New York, 1<sup>st</sup> Edition, 2001.
3. Bedient, P.B., Refai, H. S. and Newell, C. J., *Ground Water Contamination: Transport and Remediation*, Prentice Hall Publications, 2<sup>nd</sup> Edition, 1999.
4. LaGrega, M. D., Buckingham, P. L. and Evans, J. C., *Hazardous Waste Management*, New Delhi, MedTech, 2<sup>nd</sup> Edition, 2015.

**ADDITIONAL LEARNING RESOURCES:**

1. Wise, D.L., Trantolo, D.J., Inyang, H.I. and Cichon, E.J., *Remediation Engineering of Contaminated Soils*, Marcel Dekker Inc, 1<sup>st</sup> Edition, 2000.
2. Fredlund, D.G. and Rahardjo, H., *Soil Mechanics for Unsaturated Soils*, Wiley-Interscience, USA, 1<sup>st</sup> Edition, 1993.
3. Hillel, D., *Introduction to Environmental Soil Physics*, Academic Press, New York, 1<sup>st</sup> Edition, 2003.
4. Sparks, D.L., *Environmental Soil Chemistry*, Academic Press, New York, 2<sup>nd</sup> Edition, 2002.



### III B. Tech. – II Semester

#### (19BT60111) GLOBAL POSITIONING SYSTEM

(Professional Elective – 2)

Int. Marks	Ext. Marks	Total Marks	L	T	P	C
40	60	100	3	-	-	3

**PRE-REQUISITES:** Course on Physics.

**COURSE DESCRIPTION:** Geodesy; Overview of Global Positioning System (GPS); GPS signal structure; GPS Errors and accuracy; GPS surveying and applications.

**COURSE OUTCOMES:** After successful completion of the course, students will be able to:

- CO1 Analyze geodesy to solve complex problems of global positioning system using appropriate techniques considering society and ethics besides communicating effectively in graphical form.
- CO2 Analyze GPS to solve complex navigation problems using appropriate tools and techniques considering society and ethics besides communicating effectively in graphical form.
- CO3 Analyze GPS signal structure to solve complex GPS problems using appropriate tools and techniques considering society and ethics besides communicating effectively in graphical form.
- CO4 Analyze GPS errors and accuracy to solve complex GPS problems using appropriate tools and techniques considering society and ethics besides communicating effectively in graphical form.
- CO5 Analyze GPS Surveying and applications to solve complex surveying problems using appropriate tools and techniques following latest developments considering society, environment, sustainability and ethics besides communicating effectively in graphical form.

#### **DETAILED SYLLABUS:**

##### **UNIT – I: GEODESY**

**(09 Periods)**

Fundamentals of geodesy, Earth geoid and ellipsoid, Reference surface, geodetic systems, Indian geodetic system, Coordinate systems and transformations.

##### **UNIT – II: OVERVIEW OF GLOBAL POSITIONING SYSTEM**

**(08 Periods)**

NAVSTAR GPS, GLONASS, Indian regional navigational Satellite system, Segments of GPS, Blocks of GPS - Block I, II/IIA; Advantages and current limitations of GPS.

##### **UNIT – III: GPS SIGNAL STRUCTURE**

**(09 Periods)**

Carriers, GPS codes - C/A, P, Navigational message; GPS receiver - Types and structure of receivers; Principles of GPS position fixing, Pseudo ranging.

##### **UNIT – IV: GPS ERRORS AND ACCURACY**

**(09 Periods)**

Satellite dependent - Ephemeris errors, Satellite clock bias, Selective availability; Receiver dependent - Receiver clock bias, Cycle slip, Selective availability; Observation medium dependent: Ionospheric errors, Tropospheric errors; Station dependent - Multipath, Station coordinates; Satellite geometry based measures - Geometry dependent (Dilution of Precision: DOP), User equivalent range error.

## **UNIT – V: GPS SURVEYING AND APPLICATIONS**

**(10 Periods)**

Static surveying and kinematics surveying, DGPS survey, Preparation of GPS surveys - Setting up an observation plan, Observation strategies, Network design; GPS applications - Cadastral surveys, Remote sensing and GIS, Military applications and vehicle tracking, Infrastructure development, Natural disasters, Latest advancements in GPS applications.

**Total Periods: 45**

**Topics for self-study are provided in the lesson plan.**

### **TEXT BOOKS:**

1. Sateesh Gopi, *Global Positioning Systems – Principles and Applications*, McGraw Hill Education (India) Pvt. Ltd., 2014.
2. Akash Deep Sharma, *Global Positioning System*, MD Publication Pvt. Ltd., New Delhi (India), 2008.

### **REFERENCE BOOKS:**

1. Gunter Seeber, *Satellite Geodesy*, Walter De Gruyter, Berlin (Germany), 2<sup>nd</sup> Edition, 2003.
2. Pratap Misra and Per Enge, *Global Positioning System*, Ganga Jamuna Press, 2006.
3. Bradford, W. Parkinson and James J. Spiker Jr., *Global Positioning System: Theory and Applications, Vol I and II*, American Institute of Aeronautics and Astronautics: Washington (USA), 1996.
4. Hofmann Wellenhof, B., Lichtenegger, H. and Collins, J., *Global Positioning System: Theory and Practice*, Springer, Berlin (Germany), 1994.

### **ADDITIONAL LEARNING RESOURCES:**

1. Mohinder S. Grewal, Lawrence R. Weill and Angus P. Andrews, *Global Positioning Systems, Inertial Navigation and Integration*, John Wiley & Sons, 2<sup>nd</sup> Edition, 2007.
2. Terry-Karen Steede, *Integrating GIS and the Global Positioning System*, ESRI Press,

### III B. Tech. – II Semester

#### (19BT60112) GROUNDWATER DEVELOPMENT AND MANAGEMENT

(Professional Elective – 2)

Int. Marks	Ext. Marks	Total Marks	L	T	P	C
40	60	100	3	-	-	3

**PRE-REQUISITES:** Courses on Engineering Hydrology, Irrigation Engineering and Hydraulic Structures.

**COURSE DESCRIPTION:** Groundwater occurrence and movement; Analysis of pumping test data; Saline water intrusion in an aquifer; Artificial recharge of groundwater; Groundwater exploration.

**COURSE OUTCOMES:** On successful completion of this course, the students will be able to:

- CO1. Analyze groundwater occurrence and movement to solve groundwater problems using appropriate techniques following relevant standards considering society, environment and sustainability besides communicating effectively in graphical form.
- CO2. Analyze pumping test data for solving complex ground water problems using appropriate methods considering codes of practice, health and safety, environment and sustainability besides communicating effectively in graphical form.
- CO3. Analyze saline water intrusion in an aquifer for solving complex ground water problems using appropriate techniques considering codes of practice, health, society, environment and sustainability besides communicating effectively in graphical form.
- CO4. Analyze artificial groundwater recharge sites to solve groundwater problems using appropriate tools and techniques considering society, environment and sustainability besides communicating effectively in graphical form.
- CO5. Analyze exploration to solve complex groundwater problems using appropriate tools and techniques following relevant codes of practice and latest developments considering health, safety, society, environment, sustainability and economics besides communicating effectively in graphical form.

#### **DETAILED SYLLABUS:**

##### **UNIT I- GROUNDWATER OCCURRENCE AND MOVEMENT (09 periods)**

Groundwater hydrologic cycle – Origin of groundwater; Vertical distribution of groundwater, Geological formations as aquifers, Types of aquifers, Aquifer parameters; Darcy's law, Groundwater flow equation; Groundwater flow contours and their applications.

##### **UNIT II – ANALYSIS OF PUMPING TEST DATA (10 periods)**

Steady groundwater flow towards a well in confined and unconfined aquifers, Unsteady radial flow towards a well, Non equilibrium equations – Thies solution, Jacob and Chow's solutions; Yield of an open well.

##### **UNIT III – SALINE WATER INTRUSION IN AN AQUIFER (08 periods)**

Saline water intrusion, Ghyben–Herzberg relation, Shape of interface, Effects and control of sea water intrusion, Recognition of sea water in groundwater, Case studies.

##### **UNIT IV – ARTIFICIAL RECHARGE OF GROUNDWATER (09 periods)**

Artificial recharge - Recharge methods, Merits, Application of GIS and Remote Sensing in artificial recharge of groundwater along with case studies; Conjunctive use.

#### **UNIT V – GROUNDWATER EXPLORATION**

**(10 periods)**

Groundwater exploration, Surface methods - Electrical resistivity and seismic refraction methods; Subsurface methods – Geophysical logging and resistivity logging; Field survey using electrical resistivity method, Latest developments.

**Total Periods: 45**

***Topics for self-study are provided in the lesson plan.***

#### **TEXT BOOKS:**

1. Raghunath, H. M., *Groundwater*, Wiley Eastern Ltd., 3<sup>rd</sup> Edition, 2007.
2. Todd, D. K., *Groundwater Hydrology*, Wiley India Pvt. Ltd., 3<sup>rd</sup> Edition, 2011.

#### **REFERENCE BOOKS:**

1. Karanth, K. R., *Groundwater Assessment, Development and Management*, Mc. Graw Hill Education, 1<sup>st</sup> Edition, 2017.
2. Chahar, B. R., *Groundwater Hydrology*, Mc. Graw Hill India, 2017.
3. Franklin, W. Schwartz, *Fundamentals of Ground Water*, Wiley Publication, 1<sup>st</sup> Edition, 2003.
4. Freeze, A.R. and Cherry, J.A., *Groundwater*, Prentice-Hall Publication, 2003.

#### **ADDITIONAL LEARNING RESOURCES:**

1. Ramakrishnan, S., *Groundwater*, SciTech Publications (India) Pvt. Ltd, 2<sup>nd</sup> Edition, 2014.
2. Subramanyam, K., *Engineering Hydrology*, McGraw Hill Publications, 5<sup>th</sup> Edition, 2017.

### III B. Tech. – II Semester

#### (19BT60113) REHABILITATION AND RETROFITTING OF STRUCTURES

(Professional Elective –2)

Int. Marks	Ext. Marks	Total Marks	L	T	P	C
40	60	100	3	-	-	3

**PRE-REQUISITES:** Courses on Civil Engineering Materials and Concrete Technology; Construction, Planning and Project Management; Reinforced Cement Concrete Structures.

**COURSE DESCRIPTION:** Maintenance and repair strategies; Serviceability and durability of concrete; Materials and techniques for repair; Repairs, Rehabilitation and Retrofitting of structures; Demolition techniques.

**COURSE OUTCOMES:** On successful completion of this course, the students will be able to:

- CO1 Analyze maintenance and repair strategies to solve rehabilitation and retrofitting problems of structures using various tools and techniques following relevant codes and standards considering safety, serviceability, environment and sustainability.
- CO2 Analyze the serviceability and durability of concrete to solve complex rehabilitation and retrofitting problems of structures using various tools and techniques following relevant codes and standards considering safety, serviceability, environment and sustainability besides communicating effectively in graphical form.
- CO3 Analyze materials for repair to solve complex rehabilitation and retrofitting problems of structures using tools and techniques to following relevant codes and standards considering safety, serviceability, environment and sustainability.
- CO4 Analyze various techniques for repair to solve complex rehabilitation and retrofitting problems of structures to following relevant codes, standards and latest development considering safety, serviceability, environment and sustainability.
- CO5 Analyze various rehabilitation, retrofitting and demolition procedures for repair to solve complex rehabilitation and retrofitting problems of structures to following relevant codes, standards and latest developments considering safety, serviceability, environment and sustainability besides communicating effectively in graphical form.

#### DETAILED SYLLABUS:

##### UNIT - I: MAINTENANCE AND REPAIR STRATEGIES (8 periods)

Maintenance, Repair and rehabilitation, Facets of maintenance, Importance of maintenance, various aspects of inspection, Assessment procedure for evaluating a damaged structure, Causes of deterioration.

##### UNIT - II: SERVICEABILITY AND DURABILITY OF CONCRETE (9 periods)

Quality assurance for concrete construction, Concrete properties – Strength, Permeability, Thermal properties; Cracks – Causes and effects due to climate, temperature, chemicals, and corrosion; Design and construction errors – Effects of cover thickness and cracking

**UNIT - III: MATERIALS FOR REPAIR (10 periods)**

Special concretes and mortar, Concrete chemicals, Special elements for accelerated strength gain, Expansive cement, Polymer concrete, Sulphur infiltrated concrete, Ferrocement, Fiber reinforced concrete, Rust eliminators and polymers coating for rebars during repair, Foamed concrete, Mortar and dry pack, Vacuum concrete.

**UNIT - IV: TECHNIQUES FOR REPAIR (9 periods)**

Load test for stability, Guniting and shotcrete, Epoxy injection, Mortar repair for cracks, Shoring and underpinning, Methods of corrosion protection, Corrosion inhibitors, Corrosion resistant steels, Coating to reinforcement and cathodic protection; Repairs to overcome low member strength, deflection, chemical disruption, weathering, corrosion, wear, fire, leakage and marine exposure; Latest developments.

**UNIT - V: REHABILITATION, RETROFITTING AND DEMOLITION OF STRUCTURES (9 periods)**

**Rehabilitation, Retrofitting of Structures:** Introduction to beam-shear capacity strengthening, Flexural strengthening, Column strengthening, Failure mode of masonry building, Retrofitting strategies for RC members global level and local level retrofitting; Retrofitting of historical buildings, strengthening and case studies; Latest developments.

**Demolition of Structures:** Engineered demolition techniques for dilapidated structures – Case studies.

**Total Periods: 45**

**Topics for self-study are provided in the lesson plan.**

**TEXT BOOKS:**

1. Vidivelli, B., *Rehabilitation of Concrete Structures*, Standard Publishers Distributors, 2008.
2. Bhattacharjee. J., *Concrete Structures Repair, Rehabilitation and Retrofitting*, CBS Publishers and Distributors (P). Ltd., New Delhi, 2019.

**REFERENCE BOOKS:**

1. Shetty, M. S., *Concrete Technology*, S. Chand and Company Ltd., New Delhi, 2003.
2. Zongjinli, *Advanced Concrete Technology*, John Wiley and Sons, 2011.
3. Alexander, M. G., Beushausen, H. D., Dehn, F. and Moyo, P., *Concrete Repair, Rehabilitation and Retrofitting III*, CRC Press, Balkama, 2012.
4. Guha, P. K., *Maintenance and Repairs of Buildings*, New Central Book Agency (P) Ltd., 2006.

**ADDITIONAL REFERENCE RESOURCES:**

1. Varghese. P. C., *Maintenance Repair & Rehabilitation & Minor Works of Buildings*, PHI Learning Private Limited, Delhi, 2014.
2. Alakesh Manna, *Reliability and Maintenance Engineering*, I.K. International Publishing House Pvt. Ltd., 2011.
3. Pankaj Agarwal and Manish Shrikhande, *Earthquake Resistant Design of Structures*, Prentice Hall of India, 2006.
4. *Hand book on Seismic Retrofit of Buildings*, Indian Building Congress (IBC) and Indian Institute of Technology, Madars, Narosa Publishing House, 2008.

**CODES**

IS 13935 – 2009 : Repair and Seismic Strengthening of Building

### III B.Tech. - II Semester

#### (19BT60114) **SOLID AND HAZARDOUS WASTE MANAGEMENT**

(Professional Elective-2)

Int. Marks	Ext. Marks	Total	L	T	P	C
40	60	100	3	-	-	3

**PREREQUISITES:** Course on Environmental Science.

**COURSE DESCRIPTION:** Sources and types of municipal solid wastes; Onsite handling; Storage and processing; Collection and transfer; Off-site processing and disposal, Hazardous waste management.

**COURSE OUTCOMES:** On successful completion of this course, the students will be able to:

- CO1 Analyze municipal solid waste to solve complex problems associated with it using appropriate tools and techniques, following relevant codes, regulations and latest developments considering health, society, environment, sustainability and economics besides communicating effectively in graphical form.
- CO2 Analyze on-site storage and processing of municipal solid waste to solve complex problems using appropriate tools and techniques following relevant guidelines and latest developments considering health, society, environment and sustainability and economics besides communicating effectively in graphical form.
- CO3 Analyze collection and transfer of municipal solid waste to solve complex problems using appropriate tools and techniques following relevant guidelines and latest developments considering health, society, environment, sustainability and economics besides communicating effectively in graphical form.
- CO4 Analyze off-site processing of municipal solid waste to solve complex problems using appropriate tools and techniques following relevant guidelines and latest developments considering health, society, environment, sustainability, economics and project management besides communicating effectively in graphical form.
- CO5 Design sanitary landfills to solve complex municipal solid waste disposal problems using appropriate tools and techniques following relevant guidelines and latest developments considering health, society, environment, sustainability, economics and project management besides communicating effectively in graphical form.
- CO6 Analyze hazardous waste to solve complex problems associated with it using appropriate tools and techniques following relevant codes, regulations and latest developments considering health, society, environment, sustainability and project management besides communicating effectively in graphical form.

#### **DETAILED SYLLABUS:**

##### **UNIT – I: MUNICIPAL SOLID WASTE**

**(09 Periods)**

Sources and types of solid wastes – Quantity, Factors affecting generation of solid wastes, Characteristics, Methods of sampling and characterization, , Public health effects, Social and economic aspects, Public awareness, Role of NGOs, Legislation.

##### **UNIT – II: ON-SITE STORAGE AND PROCESSING**

**(09 Periods)**

Principles of solid waste management, On-site segregation and storage methods, Materials used for containers, Public health and economic aspects of storage, Options under Indian conditions, Critical evaluation of options.

**UNIT – III: COLLECTION AND TRANSFER (09 Periods)**

Methods of collection, Types of vehicles, Manpower requirement, Analysis of Collection routes, Transfer stations, Selection of location, Operation and maintenance, Collection options under Indian conditions.

**UNIT – IV: OFF-SITE PROCESSING AND DISPOSAL (08 Periods)**

**Off-Site Processing:** Processing techniques and equipment, Resource and energy recovery from solid wastes – Composting, Incineration and pyrolysis.

**Disposal:** Dumping of solid waste, Effects of improper disposal of solid wastes, Sanitary landfills – Site selection, Design and operation of sanitary landfills, Leachate collection and treatment.

**UNIT – V: HAZARDOUS WASTE MANAGEMENT (10 Periods)**

Introduction to Hazardous wastes, Definition of Hazardous waste, The magnitude of the problem, Risk assessment, Environmental legislation, Characterization and site assessment, Waste minimization and resource recovery, Transportation and disposal of hazardous waste; Biomedical waste management – Incineration and pyrolysis.

**Total Periods: 45**

**Topics for self-study are provided in the lesson plan.**

**TEXT BOOKS:**

1. George Tchobanoglous, *Integrated Solid Waste Management*, McGraw-Hill Publishers, 2<sup>nd</sup> Edition, 2002.
2. Woodside, G., *Hazardous Materials and Hazardous Waste Management*, John Wiley & Sons, 2<sup>nd</sup> Edition, 1999.

**REFERENCE BOOKS:**

1. Ramachandra, T. V., *Management of Municipal Solid Waste*, The Energy and Resources Institute (TERI), 1<sup>st</sup> Edition, 2011.
2. *Manual on Municipal Solid Waste Management*, CPHEEO, Ministry of Urban Development, Government of India, 2000.
3. Asnani, P. U., and Chris Zurbrugg, *Improving Municipal Solid Waste Management in India: A Sourcebook for Policymakers and Practitioners*, World Bank Publications, 1<sup>st</sup> Edition, 2007.
4. Bhide, A. D. and Sundaresan, B. B., *Solid Waste Management in Developing Countries*, INSDOC, 1<sup>st</sup> Edition, 2010.

**ADDITIONAL LEARNING RESOURCES:**

1. Burke, Gwendolyn, Ben Ramnarine Singh, and Louis Theodore, *Handbook of Environmental Management and Technology*, John Wiley & Sons, 2<sup>nd</sup> Edition, 2000.



### III B. Tech. – II Semester

#### (19BT60115) TRANSPORTATION PLANNING AND MANAGEMENT

(Professional Elective-2)

Int. Marks	Ext. Marks	Total Marks	L	T	P	C
40	60	100	3	--	--	3

**PRE-REQUISITES:** Course on Transportation Engineering.

**COURSE DESCRIPTION:** Transportation planning process; Transportation surveys; Trip generation; Trip distribution; Mode choice; Trip assignment; Transport economics; Land use transportation models; Mass transit systems.

**COURSE OUTCOMES:** On successful completion of this course, the students will be able to:

- CO1 Analyze transportation planning process and surveys to solve transportation problems using appropriate techniques considering society and environment.
- CO2 Analyze trip generation and trip distribution to solve complex transportation problems using appropriate techniques considering safety besides communicating effectively in graphical form.
- CO3 Analyze mode choice and trip assignment to solve complex transportation problems using appropriate techniques following relevant guidelines considering safety besides communicating effectively in graphical form.
- CO4 Analyze transportation economics and land use transport models to solve transportation planning and management problems using appropriate techniques considering society besides communicating effectively in graphical form.
- CO5 Analyze mass transit systems to solve complex transportation problems using appropriate techniques following relevant codes and latest developments considering society and environment besides communicating effectively in graphical form.

#### **DETAILED SYLLABUS:**

#### **UNIT – I: TRANSPORTATION PLANNING PROCESS AND SURVEYS (9 Periods)**

**Transportation Planning Process:** System approach to transportation planning; Stages in transportation planning and difficulties in transportation planning process.

**Transportation Surveys:** Study area zoning, Types of surveys – Home interview survey, Commercial vehicle survey, Intermediate public transport survey, Cordon line survey, Post card questionnaire survey, Registration number survey, Tag-on-vehicle survey.

#### **UNIT-II: TRIP GENERATION AND TRIP DISTRIBUTION (9 Periods)**

**Trip Generation:** Factors governing trip generation and attraction, Multiple linear regression analysis.

**Trip Distribution:** Presentation of trip distribution data, Uniform and average factor method of trip distribution, Fratar method of trip distribution, Furness method of trip distribution, Gravity model of trip distribution.

#### **UNIT-III: MODE CHOICE AND TRIP ASSIGNMENT (9 Periods)**

**Mode Choice:** Influencing factors, Trip-end type modal split model, Trip-interchange modal split model, Disaggregate mode-choice model, Logit model of mode-Choice.

**Trip Assignment:** Description of transport network, Route choice behaviour, The minimum path, Minimum path algorithm, Route assignment techniques, All-or-nothing assignment, Multipath traffic assignment, Capacity-restrained traffic assignment.

**UNIT-IV: TRANSPORTATION ECONOMICS AND LAND USE TRANSPORT MODELS (9 Periods)**

**Transportation Economics:** Economic evaluation of highway schemes - Necessity, Cost and benefits of transportation projects; Basic principles of economic evaluation - Net present value method, Benefit/Cost ratio method, Internal rate of return method; Vehicle operating costs, Value of travel time saving, Accident costs.

**Land Use Transport Models:** Selection of land, Lowry model, Grain-Lowry model, Applications of Lowry model.

**UNIT-V: MASS TRANSIT SYSTEMS (9 Periods)**

Urban passenger transport modes and classifications; System Performance - Capacity and quality of service; Planning issues - Route determination, Network design, Service policy and schedule development; Scheduling - Trip generation, Blocking, Runcutting and rostering, Priority measures and their implementations, Improvements in mass transportation system - Issues and challenges.

**Total Periods: 45**

**Topics for self-study are provided in the lesson plan.**

**TEXT BOOKS**

1. Kadiyali, L. R., *Traffic Engineering and Transport Planning*, Khanna Publishers, New Delhi, 9<sup>th</sup> Edition, 1999.
2. Jotin Khisty, C. and Kent Lall, B., *Transportation Engineering – An Introduction*, Prentice Hall of India Pvt. Ltd., 3<sup>rd</sup> Edition, 2006.

**REFERENCES**

1. Hutchinson, B. G., *Principles of Urban Transport Systems Planning*, McGraw-Hill Book Co., New York, 1974.
2. Vuchic Vukan, R., *Urban Transit: Operations, Planning and Economics*, Prentice Hall, 2005.
3. Gray, G. E. and Hoel, L. A., *Public Transportation*, Prentice Hall, 2<sup>nd</sup> Edition, 1992.
4. Ortuzar, J. D. and Willumsen, L. G., *Modelling Transport*, Wiley, 4<sup>th</sup> Edition, 2011.

**ADDITIONAL LEARNING RESOURCES:**

1. Partha Chakroborthy and Animesh Das, *Principles of Transportation Engineering*, Prentice Hall of India Pvt. Ltd, 2<sup>nd</sup> Edition, 2017.
2. Ashish Verma and Ramanayya, T. V., *Public Transport Planning and Management in Developing Countries*, CRC Press, 2020.

### III B. Tech. – II Semester

#### (19BT60116) EARTHQUAKE RESISTANT DESIGN OF STRUCTURES

(Professional Elective – 3)

Int. Marks	Ext. Marks	Total Marks	L	T	P	C
40	60	100	3	-	-	3

**PRE-REQUISITES:** Courses on Engineering Geology, Structural Analysis, Reinforced Cement Concrete Structures

**COURSE DESCRIPTION:** Earthquake engineering; Earthquake analysis; Codal design and detailing provisions; Seismic planning; Shear walls and base isolation techniques.

**COURSE OUTCOMES:** On successful completion of this course, the students will be able to:

- CO1 Analyze earthquakes to solve earthquake engineering problems using appropriate tools and techniques following relevant IS codes considering society and environment besides communicating effectively in graphical form.
- CO2 Analyze earthquakes and seismic planning of buildings to solve complex earthquake engineering problems using appropriate techniques besides communicating effectively in graphical form.
- CO3 Design earthquake resistant structures to solve complex earthquake engineering problems using appropriate techniques and following IS codes considering safety, stability, environment and sustainability besides communicating effectively in graphical form.
- CO4 Design earthquake resistant structures to solve complex earthquake engineering problems using capacity based method and following IS codes considering safety, stability, environment and sustainability besides communicating effectively in graphical form.
- CO5 Design shear walls to solve complex earthquake engineering problems using appropriate techniques and following IS codes considering safety, stability, environment and sustainability besides communicating effectively in graphical form.
- CO6 Analyze base isolation techniques to solve earthquake engineering problems following latest developments considering safety and environment besides communicating effectively in graphical form.

#### DETAILED SYLLABUS:

##### UNIT – I: EARTHQUAKE ENGINEERING (08 Periods)

Engineering seismology, Earthquake phenomenon, Causes and effects of earthquakes, Faults, Structure of earth, Plate tectonics, Elastic rebound theory, Earthquake terminology - Source, Focus, Epicenter, Earthquake size, Magnitude and intensity of earthquakes; Classification of earthquakes, Seismic waves, Seismic zones, Seismic zoning map of India.

##### UNIT – II: SEISMIC ANALYSIS AND PLANNING (10 Periods)

**Seismic Analysis** - Rigid base excitation, Formulation of equations of motion for SDOF and MDOF Systems, Earthquake response analysis of single and multi-storied buildings, Use of response spectra.

**Seismic Planning**- Plan configurations, Torsion irregularities, Re-entrant corners, Non-parallel systems, Diaphragm discontinuity, Vertical discontinuities in load path, Irregularity in strength and stiffness, Mass irregularities, Vertical geometric irregularity, Proximity of adjacent buildings, Displacement requirements, drift requirements, Provisions for torsion.

**UNIT-III: DESIGN OF EARTHQUAKE RESISTANT STRUCTURES (10 Periods)**

Codal design & detailing provisions – Review of IS: 1893 – 2016 (Part-I), IS: 4326, IS: 13920 and SP – 34, Earthquake design philosophy – Assumptions, Design by seismic coefficient and response spectrum methods; Design of flexure members, Design of exterior columns, Design of interior columns, column subjected to bending and axial load, joint of frames, detailing of reinforcements, soft storey.

**UNIT – IV: CAPACITY BASED DESIGN (09 Periods)**

Preliminary data for plane frame, Determination of loads, Procedure for capacity-based design, Determination of moment magnification factors for column, Capacity design for shear in beams, Capacity design for shear in columns and detailing of reinforcement.

**UNIT – V: SHEAR WALL AND BASE ISOLATION TECHNIQUES (08 Periods)**

**Shear Wall:** Types, Design of shear walls as per IS: 13920 – Detailing of reinforcements.

**Base Isolation Techniques:** Seismic base isolation – Concept, Types; Various damper systems and their importance, Latest developments in earthquake resistant design.

**Total Periods: 45**

**Topics for self-study are provided in the lesson plan.**

**TEXT BOOKS:**

1. Pankaj Agarwal and Manish Shrikhande, *Earthquake Resistant Design of Structures*, Prentice Hall of India, 2006.
2. Duggal, S.K., *Earthquake Resistant Design of Structures*, Oxford University Press, 2010.

**REFERENCE BOOKS:**

1. Anil Chopra, K., *Dynamics of Structures*, Pearson Education, 3<sup>rd</sup> Edition, 2007.
2. Clough and Penzien, *Dynamics of Structures*, McGraw-Hill, 3<sup>rd</sup> Edition, 2008.
3. Mario Paz, *Structural Dynamics - Theory and Computation*, Kluwer Academic Publication, 2004.
4. Murty, C.V.R., *Earthquake Tips*, NICEE ([www.nicee.org](http://www.nicee.org)), IIT, Kanpur.

**CODES:**

IS 1893 – 2016	: Criteria for Earthquake Resistant Design of Structures
IS 4326 – 1993	: Earthquake Resistant Design and Construction of Building
IS 13920 – 1993	: Ductile detailing of RC Structures subjected to Seismic forces
IS 456 – 2000	: Practice for Plain and Reinforcing Concrete
IS 875 – 1987	: Practice for Design Loads for Buildings and Structures
SP 34	: Indian Standard Handbook for Concrete Reinforcement and Detailing, Bureau of Indian Standards, 1987.

### III B. Tech. – II Semester

#### (19BT60117) HIGHWAY CONSTRUCTION AND MAINTENANCE

(Professional Elective-3)

Int. Marks	Ext. Marks	Total Marks	L	T	P	C
40	60	100	3	--	--	3

**PRE-REQUISITES:** Transportation Engineering

**COURSE DESCRIPTION:** Highway construction; Stabilized roads; Highway drainage, Hill roads; Highway construction equipment; Highway maintenance; Road side development.

**COURSE OUTCOMES:** On successful completion of this course, the students will be able to:

- CO1 Analyze highway construction to solve complex highway engineering problems using appropriate tools and techniques following relevant codes considering society, environment and sustainability besides communicating effectively in graphical form.
- CO2 Analyze road stabilization techniques to solve complex highway engineering problems following relevant codes and latest developments considering society, environment and sustainability.
- CO3 Design highway drainage and geometric features of hill roads to solve complex highway engineering problems using appropriate techniques and following relevant codes considering society, environment and sustainability besides communicating effectively in graphical form.
- CO4 Analyze various highway construction equipment to solve highway engineering problems using appropriate tools and techniques following latest developments ensuring safety and environment.
- CO5 Analyze highway maintenance and road side development issues to solve complex highway engineering problems using appropriate tools and techniques following relevant codes considering society, environment and sustainability.

#### **DETAILED SYLLABUS:**

##### **UNIT – I: HIGHWAY CONSTRUCTION (9 Periods)**

General construction, Earth work, Construction of fill and subgrade, Gravel roads, WBM roads, Bituminous pavements, Cement concrete pavements, Different types of joints in cement concrete pavements - Joint filler and sealer; Interlocking concrete block (ICBP) pavements.

##### **UNIT-II: STABILIZED ROADS (9 Periods)**

Introduction, Properties of soil-aggregate mixes, Mechanical soil stabilization, Soil-cement stabilization, Soil-lime stabilization, Stabilization of soil using bituminous materials and special problems in soil stabilization work, Latest developments in soil stabilization for road works.

##### **UNIT-III: HIGHWAY DRAINAGE AND HILL ROADS (9 Periods)**

**Highway Drainage:** Importance of highway drainage – Requirements; Surface drainage - Design of surface drainage system; Subsurface drainage, Drainage of slopes and erosion control, Road construction in water logged areas and black cotton soils.

**Hill Roads:** General considerations, Alignment of hill roads, Geometric design of hill roads, Design and construction; Drainage and maintenance problems in hill roads.

**UNIT-IV: HIGHWAY CONSTRUCTION EQUIPMENT (9 Periods)**

Excavators - Drilling rock and earth; Aggregate production – Trucks and haulage equipment, Dozers, Scrappers; Finishing equipment, Hotmix plants for bituminous mixes, Pavers and compacting equipment for hot bituminous mixes, Plants and equipment for cement concrete and paving equipment; Piles and pile driving equipment, Air compressors and pumps, Latest developments in highway construction equipment.

**UNIT-V: HIGHWAY MAINTENANCE AND ROAD SIDE DEVELOPMENT (9 Periods)**

*Highway Maintenance:* Introduction; Pavement failures; Maintenance of highways; Pavement evaluation; Strengthening of existing pavements by overlays.

*Road Side Development:* Environment factors in planning and development of highways; Road side development and arboriculture - Planning plantation of trees, Species and their selection, Care of trees.

**Total Periods: 45**

**Topics for self-study are provided in the lesson plan.**

**TEXT BOOKS:**

1. Khanna, K. and Justo, C. E. G., *Highway Engineering*, Nem Chand & Bros, Roorkee, 10<sup>th</sup> Edition, 2014.
2. Kadiyali, L. R., *Traffic Engineering and Transport Planning*, Khanna Technical Publications, 7<sup>th</sup> Edition, 2010.

**REFERENCE BOOKS:**

1. JotinKhisty, C. and Kent Lall, B., *Transportation Engineering – An Introduction*, Prentice Hall of India Pvt. Ltd., 3<sup>rd</sup> Edition, 2016.
2. Partha Chakroborthy and Animesh Das, *Principles of Transportation Engineering*, Prentice Hall of India Pvt. Ltd, 2<sup>nd</sup> Edition, 2017.
3. Papacostas, C. S. and Prevedouros, P. D., *Transportation Engineering and Planning*, Prentice Hall of India Pvt. Ltd., 3<sup>rd</sup> Edition, 2009.
4. Mannering, F. L. and Washburn, S. S., *Principles of Highway Engineering and Traffic Analysis*, John Wiley& Sons, Inc., 5<sup>th</sup> Edition, 2013.

**ADDITIONAL LEARNING RESOURCES:**

1. Robert A. Douglas, *Low Volume Road Engineering- Design, Construction, and Maintenance*, CRC Press, 1<sup>st</sup> Edition, 2016.
2. Samantha R. Jones, *Highways-Construction, Management, and Maintenance*, Nova Science Publisher's, 1<sup>st</sup> Edition, 2010.
3. Watson, J.P., *Highway Construction and Maintenance*, Longman Scientific & Technical, 2<sup>nd</sup> Edition, 1994.

**III B.Tech - II Semester**  
**(19BT60118) INDUSTRIAL WASTEWATER TREATMENT**  
 (Program Elective – 3)

Int. Marks	Ext. Marks	Total Marks	L	T	P	C
40	60	100	3	-	-	3

**PREREQUISITES:** Course on Environmental Engineering

**COURSE DESCRIPTION:** Characteristics of industrial wastewater; Primary and secondary treatment; Advanced treatment systems; Typical industrial wastewater treatment; Wastewater minimization.

**COURSE OUTCOMES:** On successful completion of this course, the students will be able to:

- CO1 Analyze the characteristics of industrial wastewater to solve industrial waste water problems following the relevant standards and codes considering society, health, safety and environment besides communicating effectively in graphical form.
- CO2 Design primary and secondary treatment units to provide solutions to the complex problems of industrial wastewater treatment using appropriate techniques following the relevant standards and codes considering society, health, safety and environment besides communicating effectively in graphical form.
- CO3 Analyze the advanced treatment systems to solve complex environmental problems using appropriate techniques following latest developments considering the society, health, safety and environment besides communicating effectively in graphical form.
- CO4 Analyze the characteristics and treatment of wastewater from different industries to provide solutions to complex environmental problems using appropriate techniques following the relevant standards and codes considering the society, health, safety and environment besides communicating effectively in graphical form.
- CO5 Analyze the wastewater minimization techniques to solve complex environmental problems following latest developments considering society, health, safety, environment and project management besides communicating effectively in graphical form.

**DETAILED SYLLABUS:**

**UNIT – I: CHARACTERISTICS OF INDUSTRIAL WASTEWATER (08 Periods)**

Industrial sources of wastewater and characteristics, Significance in determination of characteristics for different industrial effluents, Pattern of pollution and self-purification of rivers, ISI tolerance limits for disposal of effluent into inland surface water and public sewers.

**UNIT – II: PRIMARY AND SECONDARY TREATMENT (10 Periods)**

Primary Treatment - Scope, Working principle, Functions and Design of Equalization, Neutralization, Screen chamber, Grit chamber and Primary sedimentation tanks; Secondary Treatment - Microbiological metabolism - Basic kinetic equations, Biological treatment kinetics, Growth kinetics, Oxygen requirement in aerobic process and Design of complete mix conventional biological treatment facilities.

**UNIT – III: ADVANCED TREATMENT SYSTEMS (09 Periods)**

Pollution characteristics, Toxic chemicals, Treatments – Oxidation and reduction systems, Thermal reduction, Air stripping, Membrane systems; Nitrogen removal by biological nitrification and denitrification, Phosphate removal by activated sludge process and anaerobic filters

**UNIT – IV: TYPICAL INDUSTRIAL WASTEWATER TREATMENT (09 Periods)**

Origin, Characteristics and treatment of wastewater - Paper mills, Sugar mills, Breweries, Wineries, Distilleries, Tanneries, Textile mills and dairy units.

**UNIT – V: WASTEWATER MINIMIZATION (09 Periods)**

In-plant survey, Flow measurement, Composition of wastewater generated, Analytical methods recommended for characterization, Waste volume and strength reduction, Water conservation, Factors encouraging the waste minimization, Clean-up and cleaner technologies, Remediation, Hierarchy of waste management options.

**Total Periods: 45**

***Topics for self-study are provided in the lesson plan.***

**TEXT BOOKS:**

1. Rao, M. N., and Dutta, A. K., *Waste Water Treatment*, Oxford and IBH Publishers, 3<sup>rd</sup> Edition, 2009.
2. Metcalf and Eddy, *Wastewater Engineering, Treatment and Reuse*, Mc.Graw Hill Education Private Limited, 4<sup>th</sup> Edition, 2010.

**REFERENCE BOOKS:**

1. Newmerow, *Liquid Waste of Industry*, Pearson Education Publishing Co., New Delhi, 1971.
2. Mark J. Hammer and Mark J. Hammer Jr., *Water and Wastewater Technology*, Pearson Education Publishing Co., New Delhi, 6<sup>th</sup> Edition, 2008.
3. Patwardhan, A. D., *Industrial Wastewater Treatment*, PHI Publisher, 2008.
4. Rakesh Kumar and Singh, R. N., *Municipal Water and Wastewater Treatment*, TERI, 2009.
5. Peavy, H.S., Rowe, D.R., Tchobanoglous, G., *Environmental Engineering*, McGraw- Hill Book Co., New Delhi, 1995.

**ADDITIONAL LEARNING RESOURCES:**

1. Glynn Henry, J. and Gary W. Heinke, *Environmental Science and Engineering*, Printice Hall of India Pvt. Ltd., New Delhi, 2<sup>nd</sup> Edition, 2004.
2. James E. Bailey and David F. Ollis, *Biochemical Engineering Fundamentals*, McGraw Hill Education Private Limited, Singapore, 2<sup>nd</sup> Edition, 1986.
3. Santosh Kumar Garg, *Sewage Disposal and Air Pollution Engineering*, Khanna Publishers, New Delhi, 27<sup>th</sup> Edition, 1<sup>st</sup> Reprint, 2013.
4. *Manual on Water Supply and Treatment*, CPHEEO, Government of India, New Delhi, 1999.
5. *Manual on Sewerage and Sewage Treatment*, CPHEEO, Govt. of India, New Delhi, 1993.



### III B.Tech. - II Semester

## (19BT60119) INFRASTRUCTURE DEVELOPMENT AND MANAGEMENT

(Professional Elective – 3)

Int. Marks	Ext. Marks	Total Marks	L	T	P	C
40	60	100	3	-	-	3

**PRE-REQUISITES:** Course on Construction Planning and Project Management.

**COURSE DESCRIPTION:** Infrastructure development; Overview of Indian infrastructure – Tenders, Contracts and specifications; Policies on infrastructure development; Construction and infrastructure; Infrastructure management.

**COURSE OUTCOMES:** On successful completion of this course, the students will be able to:

- CO1. Analyze the impact of infrastructure development on society, economy and environment to solve infrastructure problems ensuring sustainability.
- CO2. Analyze the Indian infrastructure to solve infrastructure problems following relevant government policies and regulations considering society, environment, sustainability and finance.
- CO3. Analyze the policies on infrastructure development to solve complex infrastructure problems considering society, environment and sustainability.
- CO4. Analyze the construction components of various infrastructure sectors to solve complex infrastructure problems following government policies and regulations considering society, environment and sustainability.
- CO5. Analyze the infrastructure management in various sectors to solve infrastructure problems using appropriate tools and techniques following relevant guidelines, policies and regulations considering society, environment and sustainability.

#### DETAILED SYLLABUS:

#### UNIT – I: INFRASTRUCTURE DEVELOPMENT (09 Periods)

Impact of infrastructure development on economic growth, standard of living and environment; Reasons for rise of public sector and government involvement in infrastructural activities, Changed socio-economic scenario and current problems and related issues.

#### UNIT – II: OVERVIEW OF INDIAN INFRASTRUCTURE (09 Periods)

**Indian Infrastructure:** Energy, Power, Water resources, Dams, Bridges, Canals, Rural Infrastructure, Urban Infrastructure, Housing, Roads, Railways, Ports, Airports, Social Infrastructure, Education, Health care, Infrastructure deficiencies.

**Tenders, Contracts and Specifications:** Public Private Partnership (PPP) contracts, Turnkey contracts, FIDIC clauses.

#### UNIT – III: POLICIES ON INFRASTRUCTURE DEVELOPMENT (09 Periods)

A historical review of the government policies on infrastructure; Current public policies on transportation, power and telecom sectors; Plans for infrastructure development; Legal framework for regulating private participation -Roads and highways, Ports and airports, Power and telecom.

#### UNIT – IV: CONSTRUCTION AND INFRASTRUCTURE (09 Periods)

Construction component of various infrastructure sectors: Highways, Ports and aviation, Oil and gas, Power, Telecom, Railways, Irrigation; Current scenario, Future needs,

Investment needed, Regulatory framework, Government policies and future plans, Technological and methodological demands on construction management in infrastructure development projects.

## **UNIT – V: INFRASTRUCTURE MANAGEMENT**

**(09 Periods)**

Importance, scope and role in different sectors of construction

- **Highway Sector:** Repayment of Funds, Toll Collection Strategy, Shadow tolling, and direct tolls, Maintenance strategy, Review of toll rates & structuring to suit the traffic demand.
- **Irrigation Projects:** Large / Small Dams, Instrumentation, Monitoring of water levels, Catchments area, Rainfall data management, Prediction, Land irrigation planning & policies, Processes Barrages, Canals.
- **Power Projects:** Power scenario in India, Estimated requirement, Generation of power distribution strategies, National grid, Load calculation & factors, Hydropower, Day to day operations, Management structures, Maintenance, Thermal Power, Nuclear Power.
- **Airports:** Requisites of domestic and International airports, Cargo and military airports, Facilities available, Terminal management, ATC.
- **Railways:** Mass Rapid Transport System MRTS, LRT, Multi-modal Transport System.

**Total Periods: 45**

**Topics for self-study are provided in the lesson plan.**

### **TEXT BOOKS:**

1. Narindar Jetli, K. and Vishal Sethi, *Infrastructure Development in India Post Liberalization Initiatives and Challenges*, New Century Publications, 2007.
2. Raghuram, G. and Jain, R., *Infrastructure Development and Financing: Towards a Public-Private Partnership*, Macmillan India Ltd., 1999.

### **REFERENCE BOOKS:**

1. Joshi, R. N., *Public Private Partnership in Infrastructure Perspectives, Principles, Practice*, Vision Books, 2000.
2. Prasanna Chandra, *Projects: Planning, Analysis, Selection, Financing, Implementation and Review*, Mc. Graw Hill Education, 8<sup>th</sup> Edition, 2014.
3. Murty, G. R. K., *Infrastructure Projects: Current Financing Trends*, ICFAI University Press, 2006.
4. Anup Chatterjee, Narinde Jetli, K. and Vishal Sethi, *Industry and Infrastructure Development in India Since 1947*, New Century Publications, 2009.

### **ADDITIONAL LEARNING RESOURCES:**

1. Hudson, W., Ralph Haas, Waheed Uddin, *Infrastructure Management: Integrating Design, Construction, Maintenance, Rehabilitation and Renovation*, McGraw-Hill Publications, 1997.
2. Alvin Goodman, Makar and Hastak, *Infrastructure Planning Handbook*, McGraw-Hill Publications, 2006.

### III B.Tech. – II Semester

#### (19BT60120) LAND SURVEY AND REAL ESTATE DEVELOPMENT

(Professional Elective–3)

Int. Marks	Ext. Marks	Total Marks	L	T	P	C
40	60	100	3	-	-	3

**PRE-REQUISITES:** Courses on Surveying.

**COURSE DESCRIPTION:** Land survey and layouts; Building bye-laws and regulations; Real estate development; Retail real estate; Portfolio and real estate management.

**COURSE OUTCOMES:** On successful completion of this course, the students will be able to:

- CO1. Analyze land survey and layouts to solve real estate problems using appropriate techniques by following relevant standards and codes considering society, environment besides communicating effectively in graphical form.
- CO2. Analyze building bye-laws and regulations to solve real estate problems by following latest developments considering society, environment besides communicating effectively in graphical form.
- CO3. Analyze real estate development to solve real estate problems following relevant standards, regulations and latest developments considering society, finance and project management.
- CO4. Analyze retail real estate to solve real estate problems following relevant standards, regulations and latest developments considering society, finance and project management.
- CO5. Analyze portfolio and real estate management to solve the real estate problems using appropriate techniques following relevant standards, regulations and latest developments considering society, finance and project management.

#### **DETAILED SYLLABUS:**

##### **UNIT - I: LAND SURVEY AND LAYOUTS (08 Periods)**

Field surveying - Definition and objectives; Concept of geoid and reference spheroids, Coordinate systems, Plane and geodetic surveys; Maps - Types, Importance, Scales or centre line, Conventional symbols and generalization; Topographic maps, Map projection systems, Sheet numbering systems, Map layout; Engineering project surveys - Requirements and specifications.

##### **UNIT – II: BUILDING BYE–LAWS AND REGULATIONS (10 Periods)**

Meaning of terms of law, legislation, ordinance, bill, act, regulation and bye-laws; Significance of law and its relationship to urban planning, Benefits of statutory backing of schemes, Law of eminent domain and police powers, Evolution of planning legislation – A brief history of planning legislation in India and abroad, Town and country planning act 1957, Improvement trust act 1961, Development authorities act 1957, State housing board act, Land acquisition act 1986, Urban land (ceiling and regulation) act 1976, Slum areas (improvement and clearance) act 1956, Rent control act 1946, Apartment ownership act 1983; Significance of land development controls – Zoning, Subdivision regulations, Building regulation and bye-laws; Land layout development.

##### **UNIT - III: REAL ESTATE DEVELOPMENT (09 Periods)**

Organizational set up and its functions, General procedure for development permission, Authorities and discretionary powers, Duties of staff, Policy decisions; Documents from owner, architect or surveyor; Permissions by corporation, Finance for investment in real properties, FDI, Method of valuation - Open lands, Rental method, Capital value, Outgoings, Depreciation, Valuation of licensed premises.

**UNIT - IV: RETAIL REAL ESTATE****(09 Periods)**

Merchandising, Warehousing, Franchising, Shopping malls, General free and unfree tenure, Land system in India, Concept of term value, Different forms of value, Supply and demand forces, Occupation value and investment value, Factors affecting changes in market value, Classification of values, Building redevelopment proposal, Slum rehabilitation and development schemes, Latest developments.

**UNIT - V: PORTFOLIO AND REAL ESTATE MANAGEMENT****(09 Periods)**

Risk management in real estate, Strategic business risks and corporate real estate, Competitive risks; Managing portfolio - Property assets, Contracts and relationships, Workplace and infrastructure; Risk management - Financial risks, Property market risks, Business risks, Understanding risks and informing decision making; Business ethics - Normative ethics, Prescriptive ethics, Applied ethics, Concept of right and duty, Definition and scope relevance in social changes, Corporate code of conduct.

**Total Periods: 45**

***Topics for self-study are provided in the lesson plan.***

**TEXT BOOKS:**

1. Mike E. Miles, Laurence M. Netherton and Adrienne Schmitz, *Real Estate Development: Principles and Process*, Urban Land Institute, 5<sup>th</sup> Edition, 2015.
2. Rena Mourouzi-Sivitanidou and Petros Sivitanides, *Market Analysis for Real Estate*, Routledge, 1<sup>st</sup> Edition, 2020.

**REFERENCE BOOKS:**

1. Charles D. Ghilani, *Elementary Surveying - An Introduction to Geomatics*, Pearson India Education Services Pvt. Ltd, 13<sup>th</sup> Edition, 2018.
2. David L. Cleland and Lewis R. Ireland, *Project Management: Strategic Design and Implementation*, McGraw-Hill Education; 5<sup>th</sup> Edition, 2006.
3. Downs, J.C., *Principles of Real Estate Management*, Institute of Real Estate Management, 1980.
4. Dutta, B.N., *Estimating and Costing in Civil Engineering*, CBS Publishers & Distributors Private Limited, 28<sup>th</sup> Edition, 2020.

**ADDITIONAL LEARNING RESOURCES:**

1. National Building Code of India 2016.

### III B.Tech. - II Semester

#### (19BT60121) SOIL DYNAMICS AND MACHINE FOUNDATIONS

(Professional Elective – 3)

Int. Marks	Ext. Marks	Total	L	T	P	C
40	60	100	3	-	-	3

**PRE-REQUISITES:** Courses on Soil Mechanics and Foundation Engineering.

**COURSE DESCRIPTION:** Fundamentals of vibration; Frequency of soil systems; Wave propagation; Dynamic soil properties; Vibration analyses; Design of machine foundations; Machine foundations on piles; Vibration isolation.

**COURSE OUTCOMES:** On successful completion of this course, the students will be able to:

- CO1 Analyze vibration; and frequency of soil systems to solve complex problems of soil dynamics using appropriate techniques through continuous learning by ensuring safety and environment besides communicating effectively in graphical form.
- CO2 Analyze wave propagation and dynamic soil properties to solve complex problems of soil dynamics using appropriate tools and techniques by following the relevant codes of practice by ensuring safety and environment besides communicating effectively in graphical form.
- CO3 Analyze vibrations in soils to solve complex problems of soil dynamics using appropriate techniques by following the relevant codes of practice by ensuring safety and environment besides communicating effectively in graphical form.
- CO4 Design machine foundations to solve complex problems of soil dynamics using appropriate techniques by following the relevant codes of practice by ensuring safety, environment and sustainability besides communicating effectively in graphical form.
- CO5 Analyze machine foundations on piles and vibration isolation techniques to solve complex problems of soil dynamics by following the relevant codes of practice by ensuring safety, environment and sustainability besides communicating effectively in graphical form.

#### **DETAILED SYLLABUS:**

#### **UNIT – I: FUNDAMENTALS OF VIBRATION AND FREQUENCY OF SOIL SYSTEMS (09 Periods)**

**Fundamentals of Vibration:** Definitions, Simple harmonic motion, Free and forced vibrations with and without viscous damping, Frequency dependent excitation, Systems under transient loads, Rayleigh's method of fundamental frequency, Logarithmic decrement, Latest methods.

**Frequency of Soil Systems:** Determination of viscous damping, Transmissibility, Systems with two and multiple degrees of freedom, Vibration measuring instruments, Latest methods.

#### **UNIT – II: WAVE PROPAGATION AND DYNAMIC SOIL PROPERTIES (09 Periods)**

**Wave Propagation:** Propagation of seismic waves in soil deposits, Attenuation of stress waves, Stress-strain behavior of cyclically loaded soils, Strength of cyclically loaded soils.

**Dynamic Soil Properties:** Dynamic soil properties, Laboratory and field testing techniques, Elastic constants of soils; Correlations for shear modulus and damping ratio in sands, gravels, clays and lightly cemented sand; Liquefaction of soils.

**UNIT - III: VIBRATION ANALYSES****(09 Periods)**

Types, General requirements, Permissible amplitude, Allowable soil pressure, Modes of vibration of a rigid foundation block, Methods of analyses, Lumped mass models, Elastic half space method, Elastodynamics, Effect of footing shape on vibratory response, Dynamic response of embedded block foundation.

**UNIT – IV: DESIGN OF MACHINE FOUNDATIONS****(09 Periods)**

Analysis and design of block foundations for reciprocating engines, Dynamic analysis and design procedure for a hammer foundation, IS Code of practice, Design procedure for foundations of reciprocating and impact type machines.

**UNIT – V: MACHINE FOUNDATIONS ON PILES AND VIBRATION ISOLATION****(09 Periods)**

**Machine Foundations on Piles:** Introduction, Analysis of piles under vertical vibrations, Analysis of piles under translation and rocking, Analysis of piles under torsion, Design procedure for a pile supported machine foundation.

**Vibration Isolation:** Types and methods of isolation, Active isolation and passive isolation, Dynamic properties of isolation materials.

**Total Periods: 45**

**Topics for self-study are provided in the lesson plan.**

**TEXT BOOKS:**

1. Braja M. Das and Ramana, G.V., *Principles of Soil Dynamics*, Cengage Learning, 2<sup>nd</sup> Edition, 2011.
2. Srinivasalu, P. and Vaidyanathan, C., *Hand Book of Machine Foundations*, Tata McGraw–Hill, 2007.

**REFERENCE BOOKS:**

1. Suresh C. Arya, Michael O'neill, W. and George Pincus, *Design of Structures and Foundations for Vibrating Machines*, Gulf Publishing Company, 1979.
2. Shamsheer Prakash, *Soil Dynamics*, McGraw Hill, 1981.
3. Swami Saran, *Soil Dynamics and Machine Foundations*, Galgotia Publications Pvt. Ltd., 2<sup>nd</sup> Edition, 2010.
4. Kameswara Rao, N. S. V., *Vibration Analysis and Foundation Dynamics*, Wheeler Publishing, 1998.

**ADDITIONAL LEARNING RESOURCES:**

1. Richart, Hall and Woods, *Vibration of Soils and Foundations*, Prentice Hall, 1970.
2. Shamsheer Prakash and Vijay Kumar Puri, *Foundations for Machines: Analysis and Design*, Wiley, 1988.

**IS CODES:**

IS 2974 – 1982 : Design and Construction of Machine Foundations.

### III B.Tech. II Semester

#### (19BT60122) SUSTAINABLE WATER RESOURCES DEVELOPMENT

(Professional Elective -3)

Int. Marks	Ext. Marks	Total Marks	L	T	P	C
40	60	100	3	-	-	3

**PRE-REQUISITES:** Course on Engineering Hydrology, Irrigation Engineering and Hydraulic Structures.

**COURSE DESCRIPTION:** Challenge of water sustainability; Water Economics; Sustainable Planning Approaches; Sustainable Practices for water resources management; Integrated Management of Water Supply.

**COURSE OUTCOMES:** On successful completion of this course, the students will be able to:

- CO1. Analyze global water issues and challenges to solve water resource problems considering latest developments, relevant guidelines, society, environment, and sustainability besides communicating effectively in graphical form.
- CO2. Analyze water resource economics as linked to hydrology, ecology, pollution, consumptive and non-consumptive uses for solving complex problems considering latest developments, relevant guidelines, society, environment, and sustainability besides communicating effectively in graphical form.
- CO3. Analyze sustainable planning approaches of water resources to solve complex problems considering relevant guidelines, latest developments and society besides communicating effectively in graphical form.
- CO4. Analyze sustainable practices to solve complex water resources problems using best management practices considering latest developments, relevant guidelines, environment and sustainability besides communicating effectively in graphical form.
- CO5. Analyze integrated management of water supply methods to solve complex water resources problems considering latest developments, relevant guidelines, environment and sustainability besides communicating effectively in graphical form.

#### **DETAILED SYLLABUS:**

##### **UNIT I – CHALLENGES OF WATER SUSTAINABILITY (9 periods)**

Water as a global issue - Key challenges, Need and importance of water resources; Ecosystem services, Water security, Sustainable water use; Overview of water resources – rivers, streams, groundwater and aquifers, lakes and reservoirs, wetlands and coastal zones; Global warming, Climate change and its impacts.

##### **UNIT II – WATER ECONOMICS (9 periods)**

Economic view of water issues, Economic characteristics of water goods and services, International funding organizations, Non-market monetary valuation methods, Water economic instruments, Policy options for water conservation and sustainable use – Case studies; Pricing -Distinction between values and charges; Private sector involvement in water resources management - PPP Objectives, Options, Processes, Experiences through case studies, Links between PPP and IWRM.

##### **UNIT III – SUSTAINABLE PLANNING APPROACHES (9 periods)**

National laws, Acts and Policies; Watershed planning, Tools for water resource analysis, Stormwater management and erosion control, Land use planning and management,

Urban hydrology -Existing systems, Impervious cover model, Trees in urban watersheds;  
Groundwater protection - A Sustainable approach, Data at the local and national levels.

#### **UNIT IV – SUSTAINABLE PRACTICES FOR WATER RESOURCES MANAGEMENT**

**(9 periods)**

River, Lake and Wetland restoration; Low-impact development and smart growth, Recreational use, Wildlife management and habitat restoration, New lakes, Reservoirs and dams, Land acquisition, Best management practices - Structural and nonstructural, Vegetative Practices, Runoff and sediment control, Wetlands; Rainwater harvesting.

#### **UNIT V – INTEGRATED MANAGEMENT OF WATER SUPPLY**

**(9 periods)**

Integrated management of water supply for large cities, Managing water supply using groundwater recharge, Assessment of surface storage requirement, Using flood water for artificial recharge and space irrigation, Optimal usage of irrigation water, Watershed approach for controlling erosion and non-point source pollutants to water bodies, Environment impact assessment of water resources – Objectives, Advantages and limitations.

**Total Periods: 45**

***Topics for self-study are provided in the lesson plan.***

#### **TEXT BOOKS:**

1. Sipes, J., *Sustainable Solutions for Water Resources Policies, Planning and Implementation*, John Wiley & Sons, Inc., 1<sup>st</sup> Edition, 2010.
2. Mays, W., *Water Resources Sustainability*, McGraw-Hill Education, 1<sup>st</sup> Edition, 2007.

#### **REFERENCE BOOKS:**

1. Ojha, C.S.P., Berndtsson, R., and Bhunya, P., *Engineering Hydrology*, Oxford University Press, 1<sup>st</sup> Edition, 2008.
2. Lenton, R., and Muller, M., *Integrated Water Resources Management in Practice*, MPG Books 1<sup>st</sup> Edition, Ltd., 2015.
3. Grigg, N.S., *Integrated Water Resources Management*, Macmillan Publishers Ltd., 1<sup>st</sup> Edition, 2016.
4. Setegn, S.G., and Donoso, M.C., *Sustainability of Integrated Water Resources Management*, Springer International Publishing Switzerland, 1<sup>st</sup> Edition, 2015.

#### **ADDITIONAL LEARNING RESOURCES:**

1. Biswas, A.K., and Cecilia, T., *Water Security, Climate Change and Sustainable Development*, Springer Singapore, Heidelberg, New York, 1<sup>st</sup> Edition, 2016.
2. Shukla, V., and Kumar, N., *Environmental Concerns and Sustainable Development*, Springer Nature Singapore Pte Ltd., 1<sup>st</sup> Edition, 2020.



**III B.Tech. II Semester**  
**(19BT60314) OPTIMIZATION TECHNIQUES**  
 (Interdisciplinary Elective-2)

Int. Marks	Ext. Marks	Total Marks	L	T	P	C
40	60	100	3	-	-	3

**PRE-REQUISITES:** A course on Differential equations and Multi variable calculus.

**COURSE DESCRIPTION:** Introduction to optimization; classical optimization techniques; classification of optimization problems; linear programming; Transshipment and Travelling salesman problem; non-linear programming; un-constrained non-linear programming; constrained non-linear programming; dynamic programming; Genetic Algorithm; Ant Colony Optimization.

**COURSE OUTCOMES:**

On successful completion of this course, the student will be able to:

- CO1. Model and solve unconstrained optimization problems.
- CO2. Apply LP Techniques and Conduct Sensitivity analysis for real life Problems
- CO3. Apply Non-Linear Programming techniques for real life problems.
- CO4. Analyze various complex problems by using Dynamic programming approaches.
- CO5. Model and solve complex problems using evolutionary algorithms to optimize the parameters.

**DETAILED SYLLABUS:**

**UNIT -I: CLASSICAL OPTIMIZATION TECHNIQUES (09 periods)**

Introduction, Engineering applications of optimization, Statement of an optimization problem, Design vector, Design constraints, Constraint surface, Objective function, Classification of optimization problems, Single variable optimization, Multi variable optimization without constraints, Multi variable optimization with equality constraints - Lagrange multipliers method; Multi variable optimization with inequality constraint - Kuhn Tucker conditions.

**UNIT -II: LINEAR PROGRAMMING (09 periods)**

Introduction, Formulation, Primal Simplex method, Dual simplex method, Sensitivity Analysis, Goal programming

**UNIT -III: NON-LINEAR PROGRAMMING (09 periods)**

One dimensional minimization methods, classification - Fibonacci method, quadratic interpolation method; classification of unconstrained minimization methods - Powell's method, steepest descent method (Cauchy's method); classification of constrained optimization techniques - interior and exterior penalty function methods.

**UNIT -IV: DYNAMIC PROGRAMMING (09 periods)**

Multistage decision processes, Concept of sub optimization and Principle of optimality, Computational procedure in dynamic programming - Calculus method, Tabular method; Linear Programming problem by dynamic programming approach, Applications - reliability problem, shortest path problem, and capital budgeting problem.

**UNIT- V: EVOLUTIONARY OPTIMIZATION ALGORITHMS (09 periods)**

Introduction to Evolutionary optimization, genetic algorithm-Mathematical Modeling of Genetic algorithm, Ant Colony Optimization, particle swarm Optimization and differential evolution techniques.

***Topics for self-study are provided in the lesson plan.***

**TEXT BOOKS:**

1. Singiresu S Rao, *Engineering Optimization: Theory and Practice*, New Age International, 3<sup>rd</sup> Edition, 2013.
2. A.Ravindran, K.M.Ragsdell, G.V.Reklaitis, *Engineering Optimization: Methods and applications*, Wiley India Pvt. Ltd., 2<sup>nd</sup> Edition, 2006.
3. Dan Simon, *Evolutionary Optimization Algorithms*, John Wiley & Sons, 2013.

**REFERENCE BOOKS:**

1. C Mohan and Kusum Deep, *Optimization Techniques*, New Age International Publishers, 1<sup>st</sup> Edition, 2010.
2. Hamdy A. Taha, *Introduction to Operations Research*, PHI, 10<sup>th</sup> Edition, 2017.

### III B. Tech. – II Semester

#### (19BT60342) THERMODYNAMICS AND HEAT TRANSFER

(Interdisciplinary Elective-2)

Int. Marks	Ext. Marks	Total Marks	L	T	P	C
40	60	100	3	-	-	3

**PRE-REQUISITES:** Courses on Applied Physics and Fluid Mechanics

**COURSE DESCRIPTION:** Thermodynamic system; Energy interactions; Heat and work Transfer in flow and non- flow systems; Laws of thermodynamics; Reversible and irreversible processes, Modes of heat transfer; One dimensional steady and transient conduction; Convection heat transfer; free convection; Heat exchangers; radiation; Concept of black body; irradiative heat exchange between surfaces.

#### **COURSE OUTCOMES:**

On successful completion of this course, students will be able to:

- CO1 Demonstrate the knowledge of thermodynamic systems, properties, and zeroth law of thermodynamics
- CO2 Analyze thermodynamic systems using First law of Thermodynamics and determine the thermodynamic properties during energy interactions in engineering application.
- CO3 Analyze thermodynamic systems using second law of Thermodynamics and determine the performance parameters of heat engine and heat pump.
- CO4 Calculate heat transfer rates and heat transfer coefficients in conduction, convection and radiation heat transfer processes.
- CO5 Analyze heat exchangers, boiler and condensers and determine heat transfer rates.

#### **DETAILED SYLLABUS:**

##### **UNIT - I: BASIC CONCEPTS OF THERMODYNAMICS (9 Periods)**

Microscopic and macroscopic point of view, Thermodynamic systems, Control volume, Thermodynamic properties, Processes, Cycle, Homogeneous and Heterogeneous systems, Thermodynamic equilibrium, Quasi – static process, Concept of continuum, Work transfer and Heat transfer, Point and path function, Zeroth law of thermodynamics.

##### **UNIT - II: FIRST LAW OF THERMODYNAMICS (9 Periods)**

First Law of Thermodynamics: First law for a closed system undergoing a cycle, First law for a closed system undergoing a change of state, Limitations of first Law, Perpetual motion machine of first kind (PMM1), Energy a property of system, First law applied to a flow process - steady flow energy equation (SFEE).

##### **UNIT - III: SECOND LAW OF THERMODYNAMICS (9 Periods)**

Second Law of Thermodynamics: Energy reservoir, Kelvin plank and Clausius statements of second law and their equivalence, PMM of second kind (PMM2), Heat engine, Refrigerator, Heat pump, Reversibility and Irreversibility, Carnot cycle.

##### **UNIT - IV: MODES OF HEAT TRANSFER (9 Periods)**

Basics of Heat Transfer, Modes and Mechanism of heat transfer, Conduction, convection and radiation, General differential equation of heat conduction - Cartesian, Cylindrical and Spherical Coordinates.

**UNIT – V: BOILERS, CONDENSERS AND HEAT EXCHANGERS (9 periods)**

**Boiling:** Pool Boiling Regimes, Determination of Heat Transfer Coefficient in Nucleate Boiling.

**Condensation:** Film wise and Drop wise Condensation.

**Heat Exchangers:** Classification of Heat Exchangers, Overall Heat Transfer Coefficient and Fouling Factor, Concepts of LMTD and NTU Methods.

**Total Periods: 45**

**Topics for self-study are provided in the lesson plan.**

**TEXT BOOKS:**

1. P. K. Nag, *Engineering Thermodynamics*, TMH, 5th Edition, 2013.
2. R.C. Sachdeva, *Fundamentals of Engineering Heat and Mass Transfer*, New Age International, 5<sup>th</sup> Edition, 2017.

**REFERENCE BOOKS:**

1. R.K.Rajput, *Thermal Engineering*, Laxmi Publications (P) Ltd, 10<sup>th</sup> Edition, 2017.
2. R.K.Rajput, *Heat and Mass Transfer*, S.Chand & Company Ltd, 7<sup>th</sup> Edition, 2018.

### III B. Tech. – I Semester

#### (19BT60123) FIRE ENGINEERING

(Interdisciplinary Elective-2)

Int. Marks	Ext. Marks	Total Marks	L	T	P	C
40	60	100	3	--	--	3

**PRE-REQUISITES:** Engineering Chemistry, Civil Engineering Materials and Concrete Technology, Environmental Studies.

**COURSE DESCRIPTION:** Physics and chemistry of fire; Fire prevention and protection; Industrial fire protection systems; Building fire safety; Explosion protecting systems.

**COURSE OUTCOMES:** On successful completion of this course, the students will be able to:

- CO1 Analyze fire characteristics to solve fire engineering problems by using appropriate tools and techniques considering health, safety and environment.
- CO2 Analyze the principles of fire prevention, detection and warning to solve fire engineering problems using appropriate tools and techniques considering health, safety and environment besides communicating effectively in graphical form.
- CO3 Analyze industrial fire protection systems to solve complex fire engineering problems by using appropriate tools and techniques considering health, safety, environment, relevant codes of practice and manage effectively.
- CO4 Design building fire safety to solve complex fire engineering problems by using appropriate techniques considering health, safety, environment, relevant codes of practice and manage effectively.
- CO5 Analyze explosion protecting systems to solve complex fire engineering problems by using appropriate tools and techniques considering health, safety, environment, sustainability, relevant codes of practice and manage effectively.

#### **DETAILED SYLLABUS:**

##### **UNIT – I: PHYSICS AND CHEMISTRY OF FIRE (09 Periods)**

Fire properties of solid, liquid and gases; Fire spread, Toxicity of products of combustion, Theory of combustion and explosion, Vapour clouds, Flash fire, Jet fires, Pool fires, Unconfined vapour cloud explosion, Shock waves, Auto-ignition, Boiling liquid expanding vapour explosion, Case studies

##### **UNIT – II: PRINCIPLES OF FIRE PREVENTION, DETECTION AND WARNING (09 Periods)**

Sources of ignition, Fire triangle, Principles of fire extinguishing, Various classes of fires – A, B, C, D & E, Types of fire extinguishers, Fire stoppers, Fire Alarm and detection systems, Fire station - Fire alarms and sirens, Maintenance of fire trucks, Firefighting foams, Escape from fire rescue operations, Fire drills, Notice, First aid for burns

##### **UNIT – III: INDUSTRIAL FIRE PROTECTION SYSTEMS (09 Periods)**

Active and passive fire protection systems, Sprinkler-hydrants-stand pipes, Special fire suppression systems like deluge and emulsifier, Selection criteria of the above installations, Reliability, Maintenance, Evaluation and standards, Hydrant pipes, Hoses, monitors, Fire watchers, Layout of stand pipes, Other suppression systems, CO2 system, Foam system, Dry chemical powder (DCP) system, Halon system, Need for halon replacement, Smoke venting, Portable extinguishers, Flammable liquids, Tank farms, Indices of inflammability.

**UNIT - IV: BUILDING FIRE SAFETY****(09 periods)**

Design of building elements for passive fire protection, Fire load, Fire resistant material and fire testing, Structural fire protection, Structural integrity, Classification of buildings based on occupancy, Concept of egress design, Exit requirements, Width calculations, fire certificates, Fire safety requirements for high rise buildings.

**UNIT – V: EXPLOSION PROTECTING SYSTEMS****(09 Periods)**

Principles of explosion, Detonation and blast waves, Explosion parameters, Explosion Protection, Containment, Flame Arrestors, Isolation, Venting, Suppression, Explosion relief of large enclosure, Explosion venting, Inert gases, Plant for generation of inert gas, Rupture disc in process vessels and lines explosion, Suppression system based on carbon dioxide (CO<sub>2</sub>) and halons-hazards in LPG, ammonia (NH<sub>3</sub>), sulphur dioxide (SO<sub>2</sub>), chlorine (Cl<sub>2</sub>) etc.

**Total Periods: 45**

**Topics for self-study are provided in the lesson plan.**

**TEXT BOOKS:**

1. Jain, V. K., *Fire Safety in Buildings*, New Age international Publishers, 3<sup>rd</sup> Edition, 2010.
2. Akhil Kumar Das, *Principles of Fire Safety Engineering*, Prentice Hall India Learning Pvt. Ltd., 2014.

**REFERENCE BOOKS:**

1. Gupta, R. S., *Hand Book of Fire Technology*, Orient Longman, Bombay 2017.
2. Sunil S. Rao, Jain, R. K. and H. I. Saluja, *Electrical Safety, Fire Safety Engineering and Mangament*, Kanna Publications, New Delhi, 2012.
3. John A. Purkiss and Long-yuan Li, *Fire Safety Engineering Design of Structures*, CRC Press, 3<sup>rd</sup> Edition, 2013.
4. Butcher, E. G. and Parnell, A. C., *Designing of Fire Safety*, David Fulton Publishers, 1983.

**ADDITIONAL LEARNING RESOURCES:**

1. Derek W. B. James, *Fire Prevention Hand Book*, Butter Worths and Company, 1986.
2. Jane Lataille, *Fire Protection Engineering in Building Design*, Butterworth-Heinemann; 1<sup>st</sup> Edition, 2002.

### III B. Tech. – II Semester

#### (19BT60124) INTELLIGENT TRANSPORTATION SYSTEMS

(Interdisciplinary Elective-2)

Int. Marks	Ext. Marks	Total Marks	L	T	P	C
40	60	100	3	--	--	3

**PRE-REQUISITES:** Course on Transportation Engineering.

**COURSE DESCRIPTION:** Intelligent Transportation Systems (ITS); Telecommunications in ITS; ITS Functional areas; ITS User needs and services; Automated highway systems.

**COURSE OUTCOMES:** On successful completion of this course, the students will be able to:

- CO1 Analyze intelligent transport systems to solve complex transportation problems using appropriate techniques following relevant guidelines and latest developments considering society and environment besides communicating effectively in graphical form.
- CO2 Analyze telecommunications in ITS to solve complex transportation problems using appropriate techniques considering society and environment besides communicating effectively in graphical form.
- CO3 Analyze ITS functional areas to solve complex transportation problems using appropriate techniques following relevant guidelines and latest developments considering society and environment.
- CO4 Analyze ITS user needs and services to solve complex transportation problems using appropriate techniques following relevant guidelines and latest developments considering safety and environment.
- CO5 Analyze automated highway systems to solve transportation problems following relevant guidelines and latest developments considering society and environment.

#### **DETAILED SYLLABUS:**

#### **UNIT – I: INTELLIGENT TRANSPORTATION SYSTEMS (ITS) (9 Periods)**

Intelligent Transportation Systems (ITS) – Definition of ITS and identification of ITS objectives, Historical background, Benefits of ITS - ITS Data collection techniques – Detectors, Automatic Vehicle Location (AVL), Automatic Vehicle Identification (AVI), Geographic Information Systems (GIS), Video data collection.

#### **UNIT-II: TELECOMMUNICATIONS IN ITS (9 Periods)**

Importance of telecommunications in the ITS system, Information management, Traffic Management Centres (TMC); Vehicle – Road side communication, Vehicle positioning system.

#### **UNIT-III: ITS FUNCTIONAL AREAS (9 Periods)**

Advanced Traffic Management Systems (ATMS), Advanced Traveller Information Systems (ATIS), Commercial Vehicle Operations (CVO), Advanced Vehicle Control Systems (AVCS), Advanced Public Transportation Systems (APTS), Advanced Rural Transportation Systems (ARTS).

#### **UNIT-IV: ITS USER NEEDS AND SERVICES (9 Periods)**

Travel and traffic management, Public transportation management, Electronic payment, commercial vehicle operations, Emergency management, Advanced vehicle safety systems, Information management.

**UNIT-V: AUTOMATED HIGHWAY SYSTEMS****(9 Periods)**

Vehicles in platoons – Integration of automated highway systems; ITS Programs in the world – Overview of ITS implementations in developed countries, ITS in developing countries.

**Total Periods: 45**

***Topics for self-study are provided in the lesson plan.***

**TEXT BOOKS:**

1. Pradip Kumar Sarkar and Amit Kumar Jain, *Intelligent Transport Systems*, PHI Learning, 2018.
2. Sussman, J. M., *Perspective on ITS*, Artech House Publishers, 2005.

**REFERENCE BOOKS:**

1. Jotin Khisty, C. and Kent Lall, B., *Transportation Engineering – An Introduction*, Prentice Hall of India Pvt. Ltd., 2006.
2. Chakroborthy, P. and Das, A., *Principles of Transportation Engineering*, Prentice Hall of India Pvt. Ltd, New Delhi, 2<sup>nd</sup> Edition, 2017.
3. Papacostas, C. S. and Prevedouros, P. D., *Transportation Engineering and Planning*, PearsonIN, 3<sup>rd</sup> Edition, 2015.
4. Mannering, Fred L., Walter P. Kilareski., Scott S. Washburn, *Principles of Highway Engineering and Traffic Analysis*, John Wiley & Sons, 3<sup>rd</sup> Edition, 2004.

**ADDITIONAL LEARNING RESOURCES:**

1. *National ITS Architecture Documentation*, US Department of Transportation, 2007.
2. Kan Paul Chen and John Miles, *ITS Hand Book 2000: Recommendations for World Road Association (PIARC)*.



### III B.Tech. – II Semester

#### (19BT60125) SMART MATERIALS AND STRUCTURES

(Interdisciplinary Elective-2)

Int. Marks	Ext. Marks	Total Marks	L	T	P	C
40	60	100	3	--	--	3

**PRE-REQUISITES:** Civil Engineering Materials and Concrete Technology; Structural Analysis; Reinforced Cement Concrete Structures; Steel Structures

**COURSE DESCRIPTION:** Smart materials and structures; Measuring techniques and types; Sensing systems; Actuators; Data acquisition and processing.

**COURSE OUTCOMES:** On successful completion of this course, the students will be able to:

- CO1. Analyze smart materials and various components of smart structures to solve problems associated with smart structures for ensuring safety and sustainability using appropriate tools and techniques in structures besides lifelong learning.
- CO2. Analyze various strain measuring tools to solve problems associated with smart structures for ensuring safety and sustainability using appropriate tools and techniques in structures besides lifelong learning.
- CO3. Analyze various sensing systems to solve problems associated with smart structures for ensuring safety and sustainability using appropriate tools and techniques in structures besides lifelong learning.
- CO4. Analyze various materials and techniques used in actuators to solve problems associated with smart structures for ensuring safety and sustainability using appropriate tools and techniques in structures besides lifelong learning.
- CO5. Analyze the signals from the smart structures and monitor the structural deficiencies prior to failure to solve problems associated with smart structures for ensuring safety and sustainability using appropriate tools and techniques in structures besides lifelong learning.

#### DETAILED SYLLABUS:

##### UNIT – I: SMART MATERIALS AND STRUCTURES (08 Periods)

Smart materials and structures, Instrumented structures functions and response Sensing systems, Self-diagnosis, Signal processing consideration, Actuation systems and effectors

##### UNIT – II: MEASURING TECHNIQUES AND TYPES (08 Periods)

Strain measuring techniques using electrical strain gauges- Types, Resistance, Capacitance, Inductance, Wheatstone bridges, Pressure transducers, Load cells, Temperature compensation, Strain rosettes.

##### UNIT–III: SENSING SYSTEMS (11 Periods)

Sensing technology, Types of sensors, Physical measurement using piezo electric strain measurement, Inductively read transducers, LVDT, Fiber optic techniques, Chemical and Bio-chemical sensing in structural assessment, Absorptive chemical sensors, Spectroscopes, Fibre optic chemical sensing systems and distributed measurement.

**UNIT – IV: ACTUATORS****(09 Periods)**

Actuator techniques, Actuator and actuator materials, Piezoelectric and electrostrictive material, Magneto structure material, Shape memory alloys, Electro rheological fluids, Electromagnetic actuation, Role of actuators and Actuator materials.

**UNIT – V: DATA ACQUISITION AND PROCESSING****(09 Periods)**

Data acquisition and processing, Signal processing and control for smart structures, Sensors as geometrical processors, Signal processing, Control system- Linear and non-linear.

**Total Periods: 45**

***Topics for self-study are provided in the lesson plan.***

**TEXT BOOKS:**

1. Brain Culshaw, *Smart Structure and Materials*, Artech House – Borton. London, 2004.
2. Srinivasan, A. V. and Michael McFarland, D., *Smart Structures: Analysis and Design*, Cambridge University Press, 2009.

**REFERENCE BOOKS:**

1. Gandhi, M.V. and Thompson, B.S., *Smart Materials and Structures*, Chapman and Hall, NewYork, 1992.
2. Mel. M Schwartz, *Encyclopedia of Smart Materials*, John Wiley and Sons Inc., 2002.
3. Srinath, L. S., Raghavan, M.R., Lingaiah, K., Gargesa. G., Pant. B., Ramachandra, K., *Experimental Stress Analysis*, Tata McGraw-Hill, 1984.
4. Dally, J. W. and Riley, W. F., *Experimental Stress Analysis*, Tata McGraw-Hill, 3<sup>rd</sup> Edition, 1991.

**ADDITIONAL LEARNING RESOURCES:**

1. Michelle Addington and Daniel L. Schodek, *Smart Materials and Technologies: For the Architecture and Design Professions*, Routledge, 2005.
2. Gauenzi, P., *Smart Structures: Physical Behaviour, Mathematical Modelling and Applications*, Wiley, 2009.
3. Cady, W. G., *Piezoelectricity Volume One*, Dover Publication, 2018.

### III B. Tech. – II Semester

#### (19BT61531) INTERNET OF THINGS LAB

(Common to CE, ME, CSE, CSSE and IT)

Int. Marks	Ext. Marks	Total Marks	L	T	P	C
50	50	100	-	1	2	2

#### PRE-REQUISITES:-

#### COURSE DESCRIPTION:

Setting up **IoT** work-flow, Programming with Python, Micro-controller programming using Arduino, Building **IoT** Applications using Raspberry Pi, **IoT** Cloud Infrastructure.

#### COURSE OUTCOMES:

After successful completion of this course, the students will be able to:

- CO1.** Design an interface to embedded systems using real time sensors with Arduino and Raspberry Pi.
- CO2.** Develop applications to capture the data generated by sensors and send to cloud.
- CO3.** Develop real time applications using NodeMCU and BLYNK.
- CO4.** Design applications to push sensor data to cloud using MQTT protocol.
- CO5.** Work independently and in team to solve problems with effective communication.

#### Theory Component:

**(10 Periods)**

Arduino IDE, 7-segment display, Servo motor, ultrasonic sensor, LCD, Flame sensor, gas sensor, Humidity & temperature sensors, MQTT protocols, ECG System, Raspberry Pi, Home security system with camera, PIR sensor, light sensor, motion detector, NodeMCU, BLYNK, cloud

#### LIST OF EXPERIMENTS:

1. (a) Design and Simulate LED 7-Segment Display interfacing with Arduino.  
(b) Design and Simulate Servo motor interfacing with Arduino.
2. (a) Design and Simulate ultrasonic sensor and LCD interfacing with Arduino.  
(b) Design and Simulate Flame Sensor interfacing with Arduino.
3. Design and Implement to capture Gas Sensor and send sensor data to cloud from your NodeMCU device using Arduino IDE.
4. Design and Implementation of Humidity and Temperature Monitoring Using Arduino and upload data to cloud using MQTT.
5. Design and Implementation of an IoT ECG (Electrocardiogram) System to record hearts electrical activity.
6. Design and Simulate controlling an LED 7-Segment Display with Raspberry Pi.
7. Design and implementation of Raspberry Pi Home Security System with Camera and PIR Sensor with Email Notifications.
8. Design and Implement to upload Light sensor (TSL) data to cloud through Raspberry Pi.
9. Design and Implementation of Motion Detector with NodeMCU and BLYNK.
10. Design and Implementation of Fire notification IoT system with BLYNK.

#### REFERENCE BOOKS:

1. Adrian McEwen and HakinCassimally, *Designing the Internet of Things*, Wiley India.
2. Simon Monk, *Programming Aurdino*, Second Edition, McGraw-Hill Education, 2016.
3. Matt Richardson and Shawn Wallace, *Getting Started with Raspberry Pi*, O'Reilly, 2014.

4. Rahul Dubey, *An Introduction to Internet of Things: Connecting Devices, Edge Gateway, and Cloud with Applications* , Cengage Learning India Pvt. Ltd,2019

### III B. Tech. – II Semester

#### (19BT60131) CIVIL ENGINEERING SOFTWARE LAB

Int. Marks	Ext. Marks	Total Marks	L	T	P	C
50	50	100	-	-	2	1

**PRE-REQUISITES:** Courses in different domains of Civil Engineering.

**COURSE DESCRIPTION:** Software tools in modeling, analysis and design of systems in different domains of Civil Engineering: Structural Engineering; Geotechnical Engineering; Transportation Engineering; Environmental Engineering; Water Resources Engineering; Construction Engineering; Surveying.

**COURSE OUTCOMES:** On successful completion of this course, the students will be able to:

- CO1. Design structures, structural components and pavements to solve complex structural engineering and pavement engineering problems using appropriate software tools and techniques following relevant codes considering safety, serviceability, environment, sustainability and cost effectiveness.
- CO2. Analyze geotechnical, water resources and environmental engineering systems to solve complex engineering problems using appropriate software tools and techniques following relevant codes considering safety, serviceability, environment, sustainability and cost effectiveness.
- CO3. Prepare project management schedules, estimation and costing reports to solve complex construction engineering problems using appropriate software tools and techniques following relevant codes and standards considering safety, serviceability, environment, sustainability.
- CO4. Perform individually or in a team besides communicating effectively in written, oral and graphical forms on computer aided structural design and detailing.

#### **DETAILED SYLLABUS:**

This laboratory provides training to the students in using popular softwares for various Civil Engineering Applications as mentioned below.

#### **LIST OF EXERCISES:**

1. **ROBOT Structure** for Structural Analysis and Design
2. **SAP 2000** for Structural Analysis and Design
3. **ETABS** for Integrated Analysis, Design and Drafting of Building Systems
4. **NISA-CIVIL** for Structural Analysis And Design
5. **PLAXIS 2D/3D** for Geotechnical Modeling Software
6. **GEOSLOPE** for Slope Stability Analysis
7. **FLAC 2D/3D** for Geotechnical Modeling Software
8. **Civil 3D** for Computer Aided Civil Engineering Drafting
9. **MXROAD SUITE** for Pavement Design, Rehabilitation and Renewal
10. **KENPAVE** for Pavement Design and Rate Analysis of Roads
11. **SYNCHRO** for Traffic Signal Timing and Analysis Software
12. **MIKE-SHE** for Hydrologic and Hydraulic Modeling
13. **HEC-HMS** for Hydrologic Modeling System
14. **SWMM** for Storm Water Management Model
15. **SWAT** for Soil and Water Assessment Tool
16. **EPANET** for Hydraulic and Water Quality Behavior of Water Distribution System
17. **OPEN FOAM** for Fluid Flow Simulation and Analysis
18. **Visual MODFLOW** for Water Resources Engineering

19. **PRIMAVERA** for Project Management
20. **MS PROJECT** for Project Management
21. **Auto Plotter** for Analysis of Surveying Results
22. **Auto CAD Revit Structure Suite** for Analysis and Design of Various Structural Members
23. **Auto CAD Revit Architecture** for Plotting the Graphical Design of Structural Members
24. **Spread Sheets** for Civil Engineering Applications

**Note:** A minimum of twelve exercises are to be performed covering all technical areas of civil engineering

**TEXT BOOKS:**

1. Shah V. L. and Karve S. R., *Illustrated Design of Reinforced Concrete Building*, Structures Publication, Pune, 7<sup>th</sup> Edition, 2014.
2. Krishnamurthy. D., *Structural Design and Drawing, Vol-II and Vol-III*, CBS Publishers and Distributors, Delhi, 2006.

**REFERENCE BOOKS:**

1. *Civil Engineering Software Lab* (SVEC19 Regulations), Department of Civil Engineering, Sree Vidyanikethan Engineering College, Tirupati.
2. Manuals supplied by the Software Providers.

**CODES:**

- IS 456 – 2000 : Plain and Reinforced Concrete, Bureau of Indian Standards, New Delhi.  
IS 800 – 2007 : General Construction in Steel, Bureau of Indian Standards, New Delhi.  
SP-16 – 1980 : Design Aids for Reinforced Concrete, Bureau of Indian Standards, New Delhi.  
SP-34 – 1987 : Hand Book on Concrete Reinforcement and Detailing, Bureau of Indian Standards, New Delhi.

### III B.Tech. - II semester

#### (19BT60132) **SOCIALLY RELEVANT PROJECT-2**

Int. Marks	Ext. Marks	Total Marks	L	T	P	C
50	50	100	-	-	-	1

**PREREQUISITES: -**

**COURSE DESCRIPTION:** Identification of topic for the socially relevant project; Literature survey; Collection of preliminary data; Identification of implementation tools and methodologies; Performing critical study and analysis of the topic identified; Time and cost analysis; Implementation of the socially relevant project; Preparation of thesis and presentation.

**COURSE OUTCOMES:** On successful completion of the course, the students will be able to:

- CO1 Create/Design engineering systems or processes to solve complex societal problems using appropriate tools and techniques following relevant standards, codes, policies, regulations and latest developments.
- CO2 Consider environment, sustainability, economics and project management in addressing societal problems.
- CO3 Perform individually or in a team besides communicating effectively in written, oral and graphical forms on socially relevant project.

### III B. Tech. - II Semester

#### (19BT5MC01) UNIVERSAL HUMAN VALUES

(Mandatory Course)

(Common to CE, ME, EEE, ECE and EIE)

Int. Marks	Ext. Marks	Total Marks	L	T	P	C
40	-	40	2	-	-	-

#### PRE-REQUISITES: -

**COURSE DESCRIPTION:** Process for Value Education; Harmony in the Human Being - Harmony in Myself!; Harmony in Family and Society- Human Relationship; Harmony in the Nature and Existence – Coexistence; Implications of Holistic Understanding of Harmony on Professional Ethics.

**COURSE OUTCOMES:** After successful completion of the course, students will be able to:

- CO1 Understand Values and skills for sustained happiness and prosperity.
- CO2 Analyse realistic implications of a Holistic understanding of ethical human conduct, trustful and mutually fulfilling human behaviour.
- CO3 Apply holistic approach in personal life and profession through a positive understanding of the Human reality and existence.

#### DETAILED SYLLABUS:

##### UNIT I: VALUE EDUCATION (6 Periods)

Human Values-Introduction; Self-Exploration - Natural Acceptance; Human Aspirations- Right understanding- the current scenario: understanding and living in harmony.

##### UNIT II: HUMAN BEING AND SELF (6 Periods)

Understanding human being - I' and the material 'Body'; needs of Self ('I') and 'Body'- happiness and physical facility; Body as an instrument of 'I' - characteristics and activities of 'I' and harmony in 'I'; harmony of I with the Body.

##### UNIT III: FAMILY, THE SOCIETY AND THE NATIONS (6 Periods)

Values in human relationship (nine universal values) - foundational values of relationship; Difference between intention and competence; Difference between respect and differentiation; harmony in the society; Universal harmonious order in society.

##### UNIT IV: HARMONY WITH THE NATURE (6 Periods)

Harmony in the Nature; Interconnectedness and mutual fulfilment - the four orders of nature - Recyclability and Self-regulation; Existence as Co-existence; Holistic perception of harmony and existence.

##### UNIT V: HARMONY WITH PROFESSIONAL ETHICS (6 Periods)

Acceptance of human values; Ethical Human Conduct; Basis for Humanistic Education; Competence in professional ethics; Case studies: Holistic technologies, Management Models and Production Systems; Socially and ecologically responsible engineers, technologists and managers - enriching institutions and organizations.



**Total Periods: 30**

**TEXT BOOKS:**

1. Human Values and Professional Ethics by R R Gaur, R Sangal, G P Bagaria, Excel Books, New Delhi, 2010

**REFERENCE BOOKS:**

1. JeevanVidya: EkParichaya, A Nagaraj, JeevanVidya Prakashan, Amarkantak, 1999.

## IV B.Tech. - I Semester

### (19BT6HS01) PRINCIPLES OF BUSINESS ECONOMICS AND ACCOUNTANCY

(Common to All Branches)

Int. Marks	Ext. Marks	Total Marks	L	T	P	C
40	60	100	3	-	-	3

#### PRE REQUISITE: --

**COURSE DESCRIPTION:** Business economics and demand analysis; theory of production and cost analysis; markets and pricing; principles of accounting and capital; final accounts and tally erp 9.0

**COURSE OUTCOMES:** On successful completion of the course, students will be able to:

- CO1 Demonstrate Knowledge in concepts, principles and significance of Business Economics Financial accounting and Tally ERP 9.0
- CO2 Demonstrate analytical skills in managerial decision making of an organization by applying theories of Economics
- CO3 Develop effective communication in Business and Accounting transactions.
- CO4 Ascertain the profitability and soundness of an organization.
- CO5 Preparing Financial Statements

#### DETAILED SYLLABUS:

#### UNIT – I: BUSINESS ECONOMICS AND DEMAND ANALYSIS (9 periods)

Definition - Nature and Scope of Business Economics - **Demand:** Determinants of demand – Demand function - Law of demand, assumptions and exceptions - Elasticity of demand – Types of elasticity of demand - Demand forecasting and methods of demand forecasting.

#### UNIT – II: THEORY OF PRODUCTION AND COST ANALYSIS (9 periods)

**Production Function:** Input-output relationship - Law of Variable proportion- Isoquants and Isocosts

**Cost Concepts:** Total, Average and Marginal Cost - Fixed vs. Variable costs – Opportunity Costs Vs Outlay Costs– Separable Costs Vs Joint Costs, Urgent Costs Vs Postponable Costs- Avoidable Costs Vs Unavoidable Costs

**Break Even Analysis (BEA)** – Assumptions, Merits and demerits - Determination of Break Even Point (Simple problems).

#### UNIT – III: MARKETS AND PRICING (9 periods)

**Market Structure:** Types of Markets - Features of perfect competition - Monopoly and monopolistic competition - Price and Output determination in perfect competition, monopoly and monopolistic Markets.

**Pricing:** Objectives and policies of pricing – Sealed bid pricing - Marginal cost pricing - Cost plus pricing - Going rate pricing – penetration Pricing –skimming Pricing - Block pricing – Peak load pricing - Cross subsidization.

**UNIT – IV: PRINCIPLES OF ACCOUNTING & CAPITAL****(9 periods)**

**Accountancy:** Introduction – Concepts – Conventions – Double Entry Book Keeping – Journal – Ledger - Trial Balance (Simple problems)

**Capital:** Significance - Types of capital – Sources of Capital.

**UNIT – V: FINAL ACCOUNTS & TALLY ERP 9.0****(9 periods)**

**Introduction to Final Accounts** - Trading account - Profit and Loss account and Balance Sheet with simple adjustments (Simple problems)

**Tally ERP 9.0:** Introduction – Create a company – Create ledger – Posting vouchers – Advantages of Tally.

**Total Periods: 45****TEXT BOOKS:**

1. H L Ahuja, *Business Economics (Thirteenth edition)*, S Chand Publishing, Jan 2016.
2. Larry M. Walther, *Financial Accounting*, Create Space Independent Publishing Platform, July 2017.

**REFERENCE BOOKS:**

1. Joseph G.Nellis and David Parker, *Principles of Business Economics*, Pearson Education Canada, 2<sup>nd</sup> edition, 2016.
2. S.P. Jain and K.L. Narang, *Financial Accounting*, Kalyani Publishers, Ludhiana, 12<sup>th</sup> Edition, 2018.

## IV B. Tech. – I Semester

### (19BT70101) ESTIMATION AND QUANTITY SURVEYING

Int. Marks	Ext. Marks	Total Marks	L	T	P	C
40	60	100	3	-	-	3

**PRE-REQUISITES:** Courses on Civil Engineering Materials and Concrete Technology; Construction, Planning and Project Management; Surveying, Computer Aided Building Planning and Drawing.

**COURSE DESCRIPTION:** Estimation of residential buildings; Estimation of other structures; Specifications and rate analysis; Contracts and tenders; Valuation.

**COURSE OUTCOMES:** On successful completion of this course, the students will be able to:

- CO1. Estimate various components of residential buildings to solve complex problems of estimation using appropriate techniques by following relevant standards and codes besides communicating effectively in graphical form.
- CO2. Estimate other structures to solve complex problems of estimation using appropriate techniques by following relevant standards and codes besides communicating effectively in graphical form.
- CO3. Analyze specifications and rates for different items of building construction to solve complex problems of estimation using appropriate techniques by following relevant standards, codes and latest developments considering society.
- CO4. Prepare contracts and tenders to solve the complex problems using appropriate techniques by following relevant standards and latest developments considering society, legal issues, environment, sustainability, project management and financial besides communicating effectively in graphical form.
- CO5. Prepare valuation reports to solve the complex problems using appropriate techniques by following relevant standards and latest developments considering society, legal issues, project management and financial besides communicating effectively in graphical form.

#### DETAILED SYLLABUS:

##### **UNIT - I: ESTIMATION OF RESIDENTIAL BUILDINGS (10 Periods)**

Types of estimation, Methods of estimation, Load bearing and framed structures – Calculation of quantities of earth work excavation, Brick work, RCC, PCC, Plastering, White washing, Color washing and painting/varnishing for shops, rooms; Residential building with flat and pitched roof, Various types of arches, Calculation of brick work and RCC works in arches; Estimate of joineries for paneled and glazed doors, windows, ventilators etc.

##### **UNIT - II: ESTIMATION OF OTHER STRUCTURES (10 Periods)**

Estimating different structures - Septic tank, Soak pit, Sanitary and water supply installations, Water supply pipe line, Sewer line, Tube well, Open well, Roads, Retaining walls, Culverts.

##### **UNIT - III: SPECIFICATIONS AND RATE ANALYSIS (09 Periods)**

Purpose and method of writing specifications, General and detailed specification for different items of building construction, Lead statement, Data, Schedule of rates, Rate analysis -Concrete, Brick work, Plastering, Flooring and Painting.

##### **UNIT - IV: CONTRACTS AND TENDERS (08 Periods)**

Purpose of contract, Types of contract, Agreement, Tenders, Tender notice and form, Arbitration, Legal requirements.

**UNIT - V: VALUATION**

**(08 Periods)**

Necessity, Basics of value engineering, Capitalized value, Depreciation, Escalation, Value of building, Calculation of standard rent, Mortgage, Lease.

**Total Periods: 45**

**Topics for self-study are provided in lesson plan.**

**TEXT BOOKS:**

1. Dutta. B.N., *Estimating and Costing in Civil Engineering*, UBS Publishers & Distributors Pvt. Ltd., 28<sup>th</sup> Edition, 2003.
2. Kohli, D.D. and Kohli, R.C., *A Text Book of Estimating and Costing (Civil)*, S. Chand & Company Ltd., 13<sup>th</sup> Edition, 2013.

**REFERENCE BOOKS:**

- 1 Chakraborti, M., *Estimating Costing Specification and Valuation in Civil Engineering*, Laxmi Publications, New Delhi, 23<sup>rd</sup> Edition, 2010.
- 2 Frank R. Dagastino and Steven J. Peterson, *Estimating in Building Construction*, 1989 Pearson Education, Inc., 7<sup>th</sup> Edition, 2011.
- 3 Rangawala, *Estimation, Costing and Valuation*, Charotar Publishing House Pvt. Ltd., 17<sup>th</sup> Edition, 2020.
- 4 Dieter Jacob and Clemens Muller, *Estimating in Heavy Constructions*, Wilhem Ernst and Sohn Publisher, Berlin, Germany, 2017

**ADDITIONAL LEARNING RESOURCES:**

1. *National Building Code of India*, BIS, Government of India, New Delhi, 2005.
2. *Standard Schedule of Rates and Standard Data Book*, Public Works Department.

**CODES:**

IS 1200(Parts I to XXV) – 1974 : *Method of Measurement of Building and Civil Engineering Works.*

## IV B. Tech. – I Semester

### (19BT70102) GEOSPATIAL TECHNOLOGIES

Int. Marks	Ext. Marks	Total Marks	L	T	P	C
40	60	100	3	-	-	3

**PRE-REQUISITES:** Course on Surveying.

**COURSE DESCRIPTION:** Photogrammetry; Global positioning system; Remote sensing; Geographic information system; GIS spatial analysis; Remote sensing and GIS applications.

**COURSE OUTCOMES:** On successful completion of this course, the students will be able to:

- CO1 Analyze photogrammetry to solve complex surveying problems using appropriate tools and techniques following the relevant guidelines and latest developments considering society and environment besides communicating effectively in graphical form.
- CO2 Analyze global positioning system and remote sensing to solve complex surveying problems using appropriate tools and techniques considering society and environment besides communicating effectively in graphical form.
- CO3 Analyze GIS to solve complex surveying problems using appropriate tools and techniques following latest developments besides communicating effectively in graphical form.
- CO4 Analyze GIS spatial analysis to solve complex surveying problems using appropriate tools and techniques following latest developments besides communicating effectively in graphical form.
- CO5 Analyze remote sensing and GIS applications to solve complex civil engineering problems using appropriate tools and techniques following the relevant guidelines and latest developments considering society, environment, sustainability and management principles besides communicating effectively in graphical form.

#### **DETAILED SYLLABUS:**

#### **UNIT – I: PHOTOGRAMMETRY (09 Periods)**

Principle of photogrammetry, Types of aerial photographs, Planning and execution of photographic flights, Geometry of aerial photographs, Scale of aerial photographs and its determination, Stereoscopy, Ground control, Mosaics, Parallax measurements for height determinations, Latest developments in photogrammetry.

#### **UNIT – II: GLOBAL POSITIONING SYSTEM AND REMOTE SENSING (10 Periods)**

**Global Positioning System:** Components of GPS – Space segment, Control segment, User segment, Reference systems, Satellite orbits; GPS observations, Applications.

**Remote Sensing:** Elements of remote sensing, Electromagnetic spectrum, Energy resources, Physics of radiant energy, Energy interactions with earth surface features and atmosphere, Data acquisition platforms Spectral reflectance curves, Resolution; Spectral properties of water bodies, soil and vegetation; Sensors and platforms, Visual interpretation techniques.

#### **UNIT – III: GEOGRAPHIC INFORMATION SYSTEM (10 Periods)**

GIS categories, Components of GIS, Fundamental operations of GIS, Spatial and non spatial data, Raster data and vector data, File management, Layer based GIS, Feature based GIS, Map projections, Latest developments.

**UNIT – IV: GIS SPATIAL ANALYSIS****(07 Periods)**

Database models, Data storage, Vector data storage, Attribute data storage, Data manipulation and analysis, Integrated analysis of the spatial and attribute data - DTM/DEM; Softwares – ArcGIS, QGIS and Global mapper; Latest developments in GIS software.

**UNIT – V: REMOTE SENSING AND GIS APPLICATIONS****(09 Periods)**

Land use/Land cover classification, Rainfall-runoff studies, Flood and drought impact assessment and monitoring, Drainage morphometry, Watershed management for sustainable development, Inland water quality survey and management, Regional and urban planning and management, GIS based highway alignment, GIS based traffic congestion analysis, Soil mapping – Case Studies.

**Total Periods: 45**

**Topics for self-study are provided in the lesson plan**

**TEXT BOOKS:**

1. Bhatta, B., *Remote Sensing and GIS*, Oxford University Press, 2<sup>nd</sup> Edition, 2011.
2. Anji Reddi, M., *A Text Book of Remote Sensing and Geographical Information Systems*, B. S. Publications, 2<sup>nd</sup> Edition, 2012.

**REFERENCE BOOKS:**

1. Lillesand, T. M., Kiefer, R. W. and Chipman, J. W., *Remote Sensing and Image Interpretation*, John Willey and Sons (Asia) Pvt. Ltd., 7<sup>th</sup> Edition, 2014.
2. Chandra, A. M. and Ghosh, S. K., *Remote Sensing and Geographic Information System*, Narosa Publishing House, 2<sup>nd</sup> Edition, 2015.
3. Panigrahi, N., *Geographical Information Science*, University Press, 2<sup>nd</sup> Edition, 2013.
4. Peter A. Burrage and Rachael Mc Donnell, *Principles of Geographical Information Systems*, Oxford University Press, 2<sup>nd</sup> Edition, 2014.

**ADDITIONAL LEARNING RESOURCES:**

1. Basudeb Bhatta, *Remote Sensing and GIS*, Oxford, 2<sup>nd</sup> Edition, 2011.
2. Paul A. Longley, Michale F. Goodchild, David J. Maguire, David W Rhind, *Geographic Information Science and Systems*, 4<sup>th</sup> Edition, 2015.

## IV B.Tech. - I Semester

### (19BT70103) **ADVANCED FOUNDATION ENGINEERING**

(Professional Elective – 4)

Int. Marks	Ext. Marks	Total Marks	L	T	P	C
40	60	100	3	-	-	3

**PRE-REQUISITES:** Courses on Soil Mechanics and Foundation Engineering.

**COURSE DESCRIPTION:** Shallow foundations - Bearing capacity, Settlements, Design principles; Pile foundations – Bearing Capacity, Settlements, Design; Sheet pile walls; Foundations on expansive soils; Marine substructures.

**COURSE OUTCOMES:** On successful completion of this course, the students will be able to:

- CO1. Design shallow foundations to solve complex foundation engineering problems using appropriate techniques by following relevant codes of practice considering society, environment and sustainability besides communicating effectively in graphical form.
- CO2. Design pile foundations to solve complex foundation engineering problems using appropriate techniques by following relevant codes of practice considering society, environment and sustainability besides communicating effectively in graphical form.
- CO3. Design sheet pile walls based on ground characteristics for its stability to solve complex foundation engineering problems using appropriate techniques by following relevant codes of practice considering society, environment and sustainability besides communicating effectively in graphical form.
- CO4. Design under reamed piles and breakwaters to solve complex foundation engineering problems using appropriate techniques by following relevant codes of practice considering society, environment and sustainability besides communicating effectively in graphical form.
- CO5. Analyze different foundation techniques in expansive soils to solve complex foundation engineering problems by following the ethics and considering society, environment and sustainability besides communicating effectively in graphical form.
- CO6. Analyze marine substructures to solve complex marine engineering problems by following the ethics and considering society, environment and sustainability besides communicating effectively in graphical form.

#### **DETAILED SYLLABUS:**

##### **UNIT - I: SHALLOW FOUNDATIONS**

**(09 Periods)**

Theories of bearing capacity–Hansen, Vesic; Effect of tilt, eccentricity, compressibility, non-homogeneity and anisotropy of soil on bearing capacity; Bearing capacity of footings resting on stratified soils, on slope and on top of the slopes, Settlement of foundation – 3D consolidation settlement; Bearing pressure using SPT, CPT, Dilatometer and Pressure meter, Design principles - Isolated, Combined footing and mat foundation (conventional rigid method only).

##### **UNIT – II: PILE FOUNDATIONS**

**(10 Periods)**

Bearing capacity of vertically loaded piles - Static capacity- $q$ ,  $\beta$  and  $\lambda$  Methods, IS Code; Dynamic pile capacity – Simplex and Janbu methods; Point bearing resistance with SPT and CPT results; Bearing resistance of piles on rock, Uplift resistance, Laterally loaded piles, Ultimate lateral resistance, Batter piles, Under reamed piles, Mini and micro piles;



Ultimate capacity of pile groups in compression, Pullout and lateral load, Efficiency; Settlements of pile groups, Design of simple R.C.C piles.

**UNIT – III: SHEET PILE WALLS (09 Periods)**

Sheet pile structures, Cantilever sheet pile walls in granular soils and cohesive soils, Anchored bulk head – Free earth support method, Fixed earth support method; Lateral earth pressure on braced sheet pile walls.

**UNIT – IV: FOUNDATIONS ON EXPANSIVE SOILS (08 Periods)**

Expansive soils - Nature, identification and classification; Foundations in black cotton soils – Basic foundation problems associated with black cotton soils, Lime column techniques, Use of Cohesive Non Swelling (CNS) layer below shallow foundations; Underreamed piles – Principle of functioning of underreamed pile, Analysis and design of underreamed pile.

**UNIT – V: MARINE SUBSTRUCTURES (09 Periods)**

Introduction, Types of marine structures – Breakwaters, Wharves, Piers, Sea walls, Docks, Quay walls; Design loads, Wave action, Wave pressure on vertical wall, Ship impact on piled wharf structure, Design of rubble mount breakwater and wall type breakwater.

**Total Periods: 45**

**Topics for self-study are provided in the lesson plan.**

**TEXT BOOKS:**

1. Donald P. Coduto, *Foundation Design Principles and Practices*, Pearson, 3<sup>rd</sup> Edition, 2015.
2. Swami Saran, *Analysis and Design of Substructures – Limit State Design*, Oxford & IBH Publishing Company Pvt. Ltd., 2<sup>nd</sup> Edition 2018.

**REFERENCE BOOKS:**

1. Murthy, V. N. S., *Text Book of Soil Mechanics and Foundation Engineering*, CBS Publishers & Distributors Pvt. Ltd., 3<sup>rd</sup> Edition, 2018.
2. Braja M. Das, *Principles of Foundation Engineering*, Cengage Learning India, 9<sup>th</sup> Edition, 2017.
3. Bowles J.E., *Foundation Analysis and Design*, McGraw–Hill Publishing Company, 5<sup>th</sup> Edition, 2001.
4. Shamsheer Prakash, Gopal Ranjan and Swami Saran, *Analysis and Design of Foundations and Retaining Structures*, Sarita Publishers, 2<sup>nd</sup> Edition, 1987.

**ADDITIONAL LEARNING SOURCES:**

1. Murthy, V. N. S., *Advanced Foundation Engineering*, CBS Publishers & Distributors Pvt. Ltd., 1<sup>st</sup> Edition, 2017.
2. Sitharam, T. G., *Advanced Foundation Engineering*, CRC Press, 1<sup>st</sup> Edition, 2017.

**IS CODES:**

- IS 1080 – 1985 : Design and Construction of Shallow Foundations in Soils (Other than Raft, Ring and Shell).
- IS 2911 (Part 1/Sec 3) - 2010 : Design and Construction of Pile Foundations.
- IS 6403 - 1981 : Determination of Bearing Capacity of Shallow Foundations.

## IV B. Tech. – I Semester

### (19BT70104) **ADVANCED STEEL STRUCTURES**

(Professional Elective - 4)

Int. Marks	Ext. Marks	Total Marks	L	T	P	C
40	60	100	3	--	--	3

**PRE-REQUISITES:** Courses on Structural Analysis, Steel Structures.

**COURSE DESCRIPTION:** Light gauge steel sections; Welded plate girders; Gantry girder; Steel water tanks; Steel-composite construction.

**COURSE OUTCOMES:** On successful completion of this course, the students will be able to:

- CO1. Design light gauge steel section to solve complex problems associated with steel structures using appropriate techniques following relevant codes considering safety and stability besides communicating effectively in graphical form.
- CO2. Design welded plate girders to solve complex problems associated with steel structures using appropriate techniques following relevant codes considering safety and stability besides communicating effectively in graphical form.
- CO3. Design gantry girders to solve complex problems associated with steel structures using appropriate techniques following relevant codes considering safety and stability besides communicating effectively in graphical form.
- CO4. Design steel water tanks to solve complex problems associated with steel structures using appropriate techniques following relevant codes considering safety and stability besides communicating effectively in graphical form.
- CO5. Design steel concrete composite construction to solve complex problems associated with steel structures using appropriate techniques following relevant codes considering safety and stability besides communicating effectively in graphical form.

#### **DETAILED SYLLABUS:**

#### **UNIT - I: LIGHT GAUGE STEEL SECTIONS (09 periods)**

Types of section, Material, Local Buckling of thin elements, Stiffened compression elements, Unstiffened compression elements, Compression members, Flexural members – Laterally supported and Unsupported flexural members, Connections.

#### **UNIT – II: WELDED PLATE GIRDER (10 periods)**

Design of cross section of plate girders; Design of end stiffeners, intermediate stiffeners, bearing stiffeners and horizontal stiffeners.

#### **UNIT - III: GANTRY GIRDER (09 periods)**

Gantry girder impact factors, Longitudinal forces, Design of gantry girders.

#### **UNIT - IV: STEEL WATER TANKS (09 periods)**

Specifications, Design of rectangular pressed steel tank.

#### **UNIT - V: STEEL - CONCRETE COMPOSITE CONSTRUCTION (08 periods)**

Design principles, Shear connections, Composite beam design.

**Total Periods: 45**

***Topics for self-study are provided in the lesson plan.***

**TEXT BOOKS:**

1. Punmia, B. C., Ashok Kumar Jain and Arunkumar Jain, *Design of Steel Structures*, Laxmi Publications, 2<sup>nd</sup> Edition, 2013.
2. Johnson, R.P., *Composite Structures of Steel and Concrete Beams, Slabs, Columns and Frames for Buildings - Vol.I*, Blackwell Scientific Publications, 2004.

**REFERENCE BOOKS:**

1. Ramachandra, S., *Design of Steel Structures*, Dhanpat Rai Publishing Company, 2<sup>nd</sup> Edition, 2016.
2. Arya, A. S., Ajmani, J.L., *Design of Steel Structures*, Nem Chand & Bros, 5<sup>th</sup> Edition, 2001.
3. Duggal, S. K., *Limit State Design of Steel Structures*, McGraw Hill, 3<sup>rd</sup> Edition, 2019.
4. Subramanian, N., *Design of Steel Structures*, Oxford University Press, 2<sup>nd</sup> Edition, 2018.

**ADDITIONAL LEARNING RESOURCES:**

1. Lynn S. Beedle, *Plastic Design of Steel Frames*, John Wiley and Sons, 1990.
2. Narayanan, R., *Teaching Resource on Structural Steel Design*, INSDAG, Ministry of Steel Publishing, 2000.
3. Wie Wen Yu, *Design of Cold Formed Steel Structures*, Mc Graw Hill Book Company, 1996.
4. Bhavikatti, S. S., *Design of Steel Structures by Limit State Method as Per IS: 800-2007*, I. K. International Publishing House Pvt. Ltd., 5<sup>th</sup> Edition, 2017.

**IS Codes:**

IS 811-1987	: Cold Formed Light Gauge Structural Steel Sections
IS 800 - 2007	: Indian Standard General Construction in Steel
IS 805 - 2006	: Code of Practice for Use of Steel in Gravity Water Tanks
IS 11384 - 1985	: Code of Practice for Composite Construction in Structural Steel and Concrete
IS 811 - 1987	: Specifications for Cold Formed Light Gauge Structural Steel Sections

## IV B. Tech. – I Semester

### (19BT70105) ENVIRONMENTAL HYDRAULICS

(Professional Elective–4)

Int. Marks	Ext. Marks	Total Marks	L	T	P	C
40	60	100	3	-	-	3

**PRE-REQUISITES:** Course on Engineering Hydrology, Fluid Mechanics and Environmental Engineering.

**COURSE DESCRIPTION:** Eco-hydrological background, Water uses, Hydraulic principles and Eco-friendly design approach, Water hazards and their management, Eco-technological practices for sustainable development.

**COURSE OUTCOMES:** On successful completion of this course, the students will be able to:

- CO1. Analyze eco-hydrological Processes for solving environmental hydraulic problems using different tools and techniques considering society, environment, and sustainability besides communicating effectively in graphical form.
- CO2. Analyze water uses for solving environmental hydraulic problems using different techniques considering relevant guidelines, society, environment and sustainability besides communicating effectively in graphical form.
- CO3. Design eco-friendly water systems for solving complex environmental hydraulic problems using different tools and techniques, relevant guidelines, environment and sustainability besides communicating effectively in graphical form.
- CO4. Analyze water hazard classes for solving complex environmental hydraulic problems using different tools and techniques considering latest developments, relevant guidelines, safety, environment and sustainability besides communicating effectively in graphical form.
- CO5. Analyze eco-technological water management practices for solving complex environmental hydraulic problems using different tools and techniques considering latest developments, relevant guidelines, safety, environment and sustainability besides communicating effectively in graphical form.

#### **DETAILED SYLLABUS:**

#### **UNIT - I: ECO-HYDROLOGICAL BACKGROUND (09 Periods)**

Environmental Hydrology in General, Hydrologic Cycle and its Processes, Rainfall-Runoff-Infiltration-Evaporation Analysis, The Water Balance, Water Bodies.

#### **UNIT - II: WATER USES (09 Periods)**

Introduction, Water supply for Rural and Urban Neighborhoods, Water for Agriculture, Water for Industries, Water for Hydropower Generation, Water for Navigation, Water for Pisciculture, Water for Recreation.

#### **UNIT - III: HYDRAULIC PRINCIPLES AND ECO-FRIENDLY DESIGN APPROACH (10 Periods)**

Conservation Principles in General, Mass Conservation Principle and Applications, Energy Conservation Principle and Applications, Momentum Conservation Principle and Applications, Angular Momentum Conservation Principles and Applications, Flow Measurement Devices in Pipes and Open Channels, Basic Considerations for Eco-friendly Design of Water Systems.

**UNIT - IV: WATER HAZARDS AND THEIR MANAGEMENT (09 Periods)**

Overview of hazards, Water and the nature of its Pollution, Flood Disaster and its Management, Landslide Hazards and their Management, Disaster due to Collapse of Dams, Hazards due to Droughts, Information and System Organization for Disaster Mitigation.

**UNIT - V: ECO-TECHNOLOGICAL PRACTICES FOR SUSTAINABLE DEVELOPMENT (08 Periods)**

Introduction, Traditional Water Conservation Practices, Recent Eco-Technological Practices, Sustainable Development through Integrated Water Management.

**Total Periods: 45**

***Topics for self-study are provided in the lesson plan.***

**TEXT BOOKS:**

1. Ghosh, S.N. and Desai, V.R., *Environmental Hydrology and Hydraulics*, Science Publishers, 1<sup>st</sup> Edition, 2006.
2. Ward, A. D., Trimble, S. W., Burckhard, S. R. and Lyon, J. G. *Environmental Hydrology*, CRC Press, 1<sup>st</sup> Edition, 2016.

**REFERENCE BOOKS:**

1. Eslamian, S., *Handbook of Engineering Hydrology: Environmental Hydrology and Water Management*, CRC Press, 1<sup>st</sup> Edition, 2014.
2. Singh, V. P. and Hanger, W. H., *Environmental Hydraulics*, Springer Nature, 1996.
3. Tsanis, I., Huihua, J.W. and Valeo, S. C., *Environmental Hydraulics*, Elsevier Science, 1<sup>st</sup> Edition, 2006.
4. Tanguy, J.M., *Environmental Hydraulics*, Wiley Publication, 1<sup>st</sup> Edition, 2010.

**ADDITIONAL LEARNING RESOURCES:**

1. French, R. H., McCutcheon, S C. and Martin, J. L., *Environmental Hydraulics* (Chapter 5), *Hydraulic Design Handbook*, McGraw-Hill Professional, New York, NY, 5.1-5.33, (1999).
2. Ramos, H.M., Carravetta, A., Nabola, A. Mc. and Adeyeye K., *Environmental Hydraulics Research*, Water 2020, 12, 2749; doi:10.3390/w12102749.

## IV B. Tech. – I Semester

### (19BT70106) PAVEMENT ANALYSIS AND DESIGN (Professional Elective-4)

Int. Marks	Ext. Marks	Total Marks	L	T	P	C
40	60	100	3	--	--	3

**PRE-REQUISITES:** Transportation Engineering

**COURSE DESCRIPTION:** Factors affecting pavement design; Analysis and design of flexible pavements; Analysis and design of rigid pavements.

**COURSE OUTCOMES:** On successful completion of this course, the students will be able to:

- CO1 Analyze factors affecting pavement design to solve complex pavement engineering problems using appropriate techniques following relevant codes considering society and environment and sustainability besides communicating effectively in graphical form.
- CO2 Analyze the stresses induced in flexible pavements to solve complex pavement engineering problems using appropriate techniques following relevant codes considering safety besides communicating effectively in graphical form.
- CO3 Design the flexible pavements to solve complex pavement engineering problems using appropriate methods following relevant codes considering society, environment and sustainability besides communicating effectively in graphical form.
- CO4 Analyze the stresses induced in rigid pavements to solve complex pavement engineering problems using appropriate techniques following relevant codes considering safety besides communicating effectively in graphical form.
- CO5 Design the rigid pavements to solve complex pavement engineering problems using appropriate methods following relevant codes considering society, environment and sustainability besides communicating effectively in graphical form.

#### DETAILED SYLLABUS:

##### **UNIT – I: FACTORS AFFECTING PAVEMENT DESIGN (9 Periods)**

Types of pavement, factors affecting design of pavements - elastic modulus, Poisson's ratio, wheel load, wheel configuration and tyre pressure, ESWL concept, contact pressure, material characteristics, environmental and other factors.

##### **UNIT-II: ANALYSIS OF FLEXIBLE PAVEMENTS (9 Periods)**

Stresses in flexible pavement, Layered systems concept - One layer system, Boussinesq's two-layer system, Burmister's two-layer theory for pavement design.

##### **UNIT-III: DESIGN OF FLEXIBLE PAVEMENTS (9 Periods)**

Theoretical, empirical and semi-empirical methods –Group index method, Burmister, CBR Method, AASHTO method, IRC method.

##### **UNIT-IV: ANALYSIS OF RIGID PAVEMENTS (9 Periods)**

Stresses in rigid pavements, Relative stiffness of slab, Modulus of sub grade reaction, Westergaard's equation for calculation of stresses due to wheel loads, warping load and friction load; Bradley's stress coefficients - Design charts.

##### **UNIT-V: DESIGN OF RIGID PAVEMENTS (9 Periods)**

General design approach, PCA method, AASHTO method, IRC method; Design of slab thickness, different types of joints, tie bars, and dowel bars as per IRC guidelines.

**Total Periods: 45**

**Topics for self-study are provided in the lesson plan.**

**TEXT BOOKS**

1. Khanna, K. and Justo, C. E. G., *Highway Engineering*, Nem Chand & Bros, 10<sup>th</sup> Edition, 2014.
2. Yang H. Huang, *Pavement Analysis and Design*, Pearson Prentice Hall, 2<sup>nd</sup> Edition, 2004.

**REFERENCES**

1. JotinKhisty, C. and Kent Lall, B., *Transportation Engineering - An Introduction*, Prentice Hall of India Pvt. Ltd., 3<sup>rd</sup> Edition, 2016.
2. Partha Chakroborthy and Animesh Das, *Principles of Transportation Engineering*, Prentice Hall of India Pvt. Ltd., 2<sup>nd</sup> Edition, 2017.
3. Yoder, E. J. and Witczack, M. W., *Principles of Pavement Design*, John Wiley & Sons, New York, 2<sup>nd</sup> Edition, 1975.
4. Papacostas, C. S. and Prevedouros, P. D., *Transportation Engineering and Planning*, Prentice Hall of India Pvt. Ltd., 3<sup>rd</sup> Edition, 2009.
5. Mannering, F. L. and Washburn, S. S., *Principles of Highway Engineering and Traffic Analysis*, John Wiley & Sons, Inc., 5<sup>th</sup> Edition, 2013.

**ADDITIONAL LEARNING RESOURCES:**

1. Papagiannakis, A.T. and Masad, E.A., *Pavement Design and Materials*, John Wiley & Sons, 1<sup>st</sup> Edition, 2008.
2. Nicholas J. Garber and Lester A. Hoel, *Traffic and Highway Engineering*, Cengage Learning, 4<sup>th</sup> Edition, 2009.
3. Rajib B. Mallick and Tahat El-Korchi, *Pavement Engineering-Principles and Practice*, Taylor & Francis Group, LLC, 3<sup>rd</sup> Edition, 2018.

**CODES**

- IRC 37- 2018 : Design of Flexible Pavements.  
IRC 58 - 2015 : Design of Plain Jointed Rigid Pavements.

## IV B. Tech. – I Semester

### (19BT70107) PRESTRESSED CONCRETE

(Professional Elective –4)

Int. Marks	Ext. Marks	Total Marks	L	T	P	C
40	60	100	3	--	--	3

**PRE-REQUISITES:** Courses on Structural Analysis and Reinforced Cement Concrete Structures.

**COURSE DESCRIPTION:** Materials for prestressed concrete; Prestressing systems; Analysis of prestress; Design of section for flexure and shear; Analysis of end blocks, Composite construction of prestressed and insitu concrete.

**COURSE OUTCOMES:** On successful completion of this course, the students will be able to:

- CO1 Analyze materials and prestressing systems to solve prestressed concrete structural problems using appropriate techniques following the relevant codes of practice ensuring safety.
- CO2 Analyze prestress for flexure and losses to solve complex prestressed concrete structural problems using appropriate techniques ensuring safety.
- CO3 Design a section for flexure and shear to solve prestressed concrete structural problems following the relevant codes of practice ensuring safety.
- CO4 Design end blocks to solve prestressed concrete structural problems using appropriate techniques following the relevant codes of practice ensuring safety.
- CO5 Design composite sections of prestressed and insitu concrete to solve composite construction problems following the relevant codes of practice ensuring safety.

#### DETAILED SYLLABUS:

#### UNIT – I: MATERIALS FOR PRESTRESSED CONCRETE AND PRESTRESSING SYSTEMS (08 Periods)

Principles of prestressing, Types of prestressing, Materials - High strength concrete, High tensile steel; Advantages and limitations of pre-stressed concrete, Tensioning devices, Pretensioning and post-tensioning systems, Types - Hoyer system, Magnel Blaton system, Freyssinet system, Gifford-Udall system, Lee McCall system.

#### UNIT – II: ANALYSIS OF PRESTRESS (10 Periods)

Analysis of sections for flexure – Stress concept, Load balancing concept, Force concept; Kern zone, Pressure line, Cable zone, Losses of prestress in pre-tensioning and post-tensioning system.

#### UNIT – III: DESIGN OF SECTION FOR FLEXURE AND SHEAR (08 Periods)

Design of section for the limit state of collapse in flexure, Stress range approach, Design of shear reinforcements – IS codal provision

#### UNIT - IV: ANALYSIS OF END BLOCKS (10 periods)

Anchorage zone stresses - Guyon's method, Magnel method; Anchorage zone reinforcement, Transfer of prestress pre-tensioned members.

#### UNIT – V: COMPOSITE CONSTRUCTION OF PRESTRESSED AND INSITU CONCRETE (09 Periods)



Need of composite construction, Different types – Propped, Unpropped; Stress distribution of composite construction, Differential shrinkage, Design of composite section.

**Total Periods: 45**

**Topics for self-study are provided in the lesson plan.**

**TEXT BOOKS:**

1. Krishna Raju, N., *Prestressed Concrete*, Tata McGraw–Hill Publications, 6<sup>th</sup> Edition, 2018.
2. Rajagopalan, N., *Prestressed Concrete*, Narosa Publications, 2<sup>nd</sup> Edition, 2014.

**REFERENCE BOOKS:**

1. Ramamrutham, *Prestressed Concrete*, Dhanpat Rai Publications, 5<sup>th</sup> Edition, 2013.
2. Lin, T. Y., and Ned H. Burns, *Design of Prestressed Concrete Structures*, John Wiley and Sons, 3<sup>rd</sup> Edition, 2010.
3. Praveen Nagaraju, *Prestressed Concrete Design*, Dorling Kindersley Publication, 2013.
4. Punmia., B. C., Ashok Kumar Jain and Arun Kumar Jain, *Reinforced Concrete Structures, Vol. I*, Laxmi Publications Pvt. Ltd., New Delhi, 19<sup>th</sup> Edition, 2010.

**ADDITIONAL LEARNING RESOURCES:**

1. Naaman, A. E., *Prestressed Concrete Analysis and Design*, Mc Graw Hill India, Indian Edition, 2013.
2. Dayaratnam, P., *Prestressed Concrete Structures*, Oxford & Ibh , 2005.
3. Hurst, M. K., *Prestressed Concrete Design*, E & FN Spon, 2<sup>nd</sup> Edition, 2017.

**CODE:**

IS: 1343–2012 : Prestressed Concrete – Code of Practice

## IV B.Tech. – I Semester

### (19BT70108) RIVER ENGINEERING AND RIVER BASIN MANAGEMENT

(Professional Elective - 4)

Int. Marks	Ext. Marks	Total Marks	L	T	P	C
40	60	100	3	-	-	3

**PRE-REQUISITES:** Course on Fluid Mechanics, Hydrology

**COURSE DESCRIPTION:** River functions; river hydraulics; river flow mechanism and social aspects; river training works; river basin management.

**COURSE OUTCOMES:** On successful completion of this course, the students will be able to:

- CO1. Analyze river systems for solving river engineering problems considering society, environment, and sustainability besides communicating effectively in graphical form.
- CO2. Analyze behavior of river hydraulics for solving complex river engineering problems using different techniques considering relevant guidelines, society, environment and sustainability besides communicating effectively in graphical form.
- CO3. Analyze mechanism of river flow for solving complex river engineering problems using different tools and techniques, relevant guidelines, environment and sustainability besides communicating effectively in graphical form.
- CO4. Design river training works for solving complex river engineering problems using different tools and techniques considering relevant guidelines, safety, environment and sustainability besides communicating effectively in graphical form.
- CO5. Analyze integrated river basin management practices for solving complex river basin management problems using different tools and techniques considering latest developments, relevant guidelines, safety, environment and sustainability besides communicating effectively in graphical form.

#### DETAILED SYLLABUS:

##### **UNIT - I: RIVER FUNCTIONS (09 Periods)**

Rivers – Origin and evolution of river systems, Classification of rivers, Alluvial river channel and flood plain features, Sediment transport, River morphology and various classification schemes.

##### **UNIT - II: RIVER HYDRAULICS (09 Periods)**

Behavior of rivers - Introduction, River channel patterns, Straight river channels, Causes; River meandering – Causes, Characteristics, Shapes of meanders and control; Instability of rivers, Hydraulic geometry, Delta formation and control.

##### **UNIT - III: RIVER FLOW MECHANISM AND SOCIAL ASPECTS (09 Periods)**

Mechanics of alluvial rivers, Rivers and restoration structures, Socio-cultural influences and ethics of stream restoration.

##### **UNIT - IV: RIVER TRAINING WORKS (09 Periods)**

River training works and river regulation works, Classification, Protection for bridges with reduced waterways, Floodplain management, Waves and tides in estuaries, Interlinking of rivers, River stabilization.

**UNIT - V: RIVER BASIN MANAGEMENT****(09 Periods)**

Basic concepts of River Basin Management (RBM) - Integrated River Basin Management (IRBM), River Basin Organizations (RBOs); Theories and principles of IRBM - Need for IRBM, Irrigation-objectives and benefits of IRBM; Key Activities and Challenges in IRBM - Various Guiding Principles of IRBM, Scenarios in Developed and Developing Countries, Case studies.

**Total Periods: 45**

**Topics for self-study are provided in the lesson plan.**

**TEXT BOOKS:**

1. Garg, S. K., *River Engineering*, Khanna Publishing House, 1<sup>st</sup> Edition, 2019.
2. Gupta, K. D., *River Engineering*, Vayu Education of India, 1<sup>st</sup> Edition, 2014.

**REFERENCE BOOKS:**

1. Janson, P.L., Ph., Lvan Bendegam Jvanden Berg, Mdevries A. Zanen (Editors), *Principles of River Engineering – The non tidal alluvial rivers – Pitman*, 1<sup>st</sup> Edition, 1979.
2. Pierre, Y. J., *River Mechanics*, Cambridge University Press, 2<sup>nd</sup> Edition, 2018.
3. Bucu, D., *River Basin Management*, INTECH Publication, 2<sup>nd</sup> Edition, 2017.
4. Brebbia, C.A., *River Basin Management*, Wessex Institute of Technology, UK, 2011.

**ADDITIONAL LEARNING RESOURCES:**

1. Laurence, S., Keith P., Kevin H., Mary J. P. and David B., *Catchment and River Basin Management*, Routledge Publication, 2017.
2. Xiangzheng, D., and Gibson J., *River Basin Management*, Springer Nature, 2019.

## IV B. Tech. – I Semester

### (19BT70109) **STRUCTURAL HEALTH MONITORING**

(Professional Elective –4)

Int. Marks	Ext. Marks	Total Marks	L	T	P	C
40	60	100	3	-	-	3

**PRE-REQUISITES:** Courses on Basic Electrical and Electronics Engineering, and Civil Engineering Materials and Concrete Technology.

**COURSE DESCRIPTION:** Structural Health monitoring; Vibration based techniques for structural health monitoring; Non-Destructive testing of concrete structures; Sensors and it for health monitoring systems; Applications and case studies of SHM in civil infrastructure systems

**COURSE OUTCOMES:** On successful completion of this course, the students will be able to:

- CO1. Analyze structural health monitoring system to solve complex problems using appropriate techniques by following relevant standards considering safety and society besides communicating effectively in graphical form.
- CO2. Analyze vibration based techniques for structural health monitoring to solve complex problems using appropriate techniques by following relevant standards considering safety, society and environment besides communicating effectively in graphical form.
- CO3. Analyze non destructive testing of concrete structures to solve complex problems using appropriate tools and techniques by following standards, codes and latest developments by considering safety and environment besides communicating effectively in graphical form.
- CO4. Analyze sensors and IT for health monitoring systems to solve complex problems using appropriate tools and techniques by following relevant standards, codes and latest developments considering safety and environment besides communicating effectively in graphical form.
- CO5. Analyze applications and case studies of SHM in civil infrastructure systems to solve complex problems using appropriate tools and techniques by following relevant standards, codes and latest developments considering safety, society and environment, besides communicating effectively in graphical form.

#### **DETAILED SYLLABUS:**

##### **UNIT - I: STRUCTURAL HEALTH MONITORING (09 periods)**

Need for SHM, SHM - A way for smart materials and structures, SHM and biomimetic analog between the nervous system of a man and a structure with SHM, SHM as a part of system management, Passive and active SHM, NDE, SHM and NDECS, Basic components of SHM, Materials for sensor design.

##### **UNIT – II: VIBRATION BASED TECHNIQUES FOR STRUCTURAL HEALTH MONITORING (09 Periods)**

Introduction, Basic vibration concept for SHM, Mathematical description for structural system with damage, Linking experimental and analytical data, Damage localization and quantification, Neural network approach to SHM, Connectionist algorithms for anomaly detection, time domain damage detection methods for linear system, damage identification in non-linear system and application.

**UNIT - III: NONDESTRUCTIVE TESTING OF CONCRETE STRUCTURES(09 periods)**

Situations and contexts, Need, Classification of NDT procedures, Visual inspection, Half-Cell electrical potential methods, Schmidt rebound hammer test, Resistivity measurement, Electrical resistance, Electromagnetic methods, Radiographic testing, Ultrasonic testing, Infrared thermography, Ground penetrating radar, Radio isotope gauges, Other methods.

**UNIT - IV: SENSORS AND IT FOR HEALTH MONITORING SYSTEMS (09 periods)**

**Sensors for SHM:** Acoustic emission sensors, Ultrasonic sensors, Piezoelectric sensors and actuators, Fibre optic sensors and Laser shearography techniques, Imaging techniques.

**Information Technology for Health Monitoring:** Information gathering, Signal analysis, Information storage, Archival, Retrieval, Security, Wireless communication, Telemetry, Real time remote monitoring, Network protocols, Data analysis and interpretation.

**UNIT - V: APPLICATIONS AND CASE STUDIES OF SHM IN CIVIL INFRASTRUCTURE SYSTEMS (09 Periods)**

Capacitance probe for concrete cover, Applications for external post tensioned cables, Structural health monitoring of bridges, Structural health monitoring of cable – supported bridges, structural health monitoring of historical buildings.

**Total Periods: 45**

**Topics for self-study are provided in lesson plan**

**TEXT BOOKS:**

1. Daniel Balageas, Claus-Peter Fritzen and Alfredo Guemes, *Structural Health Monitoring*, ISTE Ltd., U.K. 2006.
2. Vistasp M. Karbhari and Farhad Ansari, *Structural Health Monitoring of Civil Infrastructure System*, Wood Head Publishing Limited, Cambridge, 2009.

**REFERENCE BOOKS:**

1. Wang, M. L., Lynch, L. P., and Sohn, H., *Sensors Technologies for Civil Infrastructure, Vol.1 & 2*, Wood Head Publishing Limited, Cambridge, 2009.
2. Philip, W., *Industrial Sensors and Applications for Condition Monitoring*, MEP, 1994.
3. Prasad, J. and Nair, C. G. K., *Non-destructive Test and Evaluation Materials*, McGraw Hill, 2<sup>nd</sup> Edition, 2011.
4. Poonam, Modi, I., and Chirag N. Patel, *Repair and Rehabilitation of Concrete Structures*, Prentice-Hall of India Pvt. Ltd., New Delhi, 2016.

**ADDITIONAL LEARNING RESOURCES:**

1. Victor Giurgiutiu, *Structural Health Monitoring with Piezoelectric Wafer Active Sensors*, Academic Press, 2010.
2. Charles R. Farrar, *Structural Health Monitoring*, John Wiley & Sons, 2012

**CODES:**

IS 13311 – 1992 (Part1) : *Non-Destructive testing of concrete – Methods of test*, January, New Delhi.

## IV B.Tech. – I Semester

### (19BT70110) ANALYSIS AND DESIGN OF COMPOSITE STRUCTURES

(Professional Elective-5)

Int. Marks	Ext. Marks	Total Marks	L	T	P	C
40	60	100	3	-	-	3

**PRE-REQUISITES:** - Courses on Structural Analysis, Reinforced Cement Concrete Structures, Steel Structures.

**COURSE DESCRIPTION:** Steel-concrete composite construction; Design of composite members; Design of shear connectors; Design of composite box girder bridges; Case studies and seismic behavior of composite structures.

**COURSE OUTCOMES:** On successful completion of this course, the students will be able to:

- CO1. Analyze steel-concrete composite construction to solve composite structures using appropriate techniques considering safety, serviceability and code of practice besides communicating effectively in graphical form.
- CO2. Design composite members to solve complex problems using appropriate techniques considering safety, serviceability and code of practice besides communicating effectively in graphical form.
- CO3. Design the shear connectors to solve complex problems using appropriate techniques considering safety, serviceability and code of practice besides communicating effectively in graphical form.
- CO4. Design composite box girder bridges to solve complex problems using appropriate techniques considering safety, serviceability and code of practice besides communicating effectively in graphical form.
- CO5. Analyze the seismic behavior of composite structures to solve complex problems using appropriate techniques considering safety, society, environment and code of practice.

#### **DETAILED SYLLABUS:**

#### **UNIT – I: STEEL-CONCRETE COMPOSITE CONSTRUCTION (09 Periods)**

Introduction to steel-concrete composite construction, Codes, Composite action, Serviceability and construction issues in design.

#### **UNIT – II: DESIGN OF COMPOSITE MEMBERS (09 Periods)**

Design of composite beams, slabs, columns and beam–columns; Design of composite trusses.

#### **UNIT – III: DESIGN OF SHEAR CONNECTORS (09 Periods)**

Shear connectors, Types, Design of connections in composite structures, Design of shear connectors, Partial shear interaction.

#### **UNIT – IV: DESIGN OF COMPOSITE BOX GIRDER BRIDGES (09 Periods)**

Introduction, Behavior of box girder bridges, Design of composite box girder bridges.

#### **UNIT – V: CASE STUDIES AND SEISMIC BEHAVIOR OF COMPOSITE STRUCTURES (09 Periods)**

Case studies on steel-concrete composite construction in buildings, seismic behavior of composite structures.

**Total Periods: 45**

**Topics for self-study are provided in the lesson plan.**

**TEXT BOOKS:**

1. Johnson R.P., *Composite Structures of Steel and Concrete Beams, Slabs, Columns and Frames for Buildings- Vol.I*, Blackwell Scientific Publications, 2004.
2. Oehlers D.J. and Bradford M.A., *Composite Steel and Concrete Structural Members: Fundamental Behaviour*, Pergamon Press, 1<sup>st</sup> Edition 2013.

**REFERENCE BOOKS:**

1. Qing Quan Liang, *Analysis and Design of Steel and Composite Structures*, CRC Press, 1<sup>st</sup> Edition, 2015.
2. Owens, G.W. and Knowles, P., *Steel Designers Manual*, Steel Concrete Institute(UK), Oxford Blackwell Scientific Publications, 1992.
3. Narayanan, R., *Steel-Concrete Composite Structures*, CRC Press, 1<sup>st</sup> Edition, 1988.
4. Manoj Kumar Buragohain, *Composite Structures: Design, Mechanics, Analysis, Manufacturing, and Testing*, CRC Press, 1<sup>st</sup> Edition, 2017.

**ADDITIONAL LEARNING RESOURCES:**

1. Ever J. Barbero, *Introduction to Composite Materials Design*, CRC Press, 3<sup>rd</sup> Edition, 2017.

**IS Codes:**

- IS: 3935 - 1966 : Code of Practice for Composite Construction.
- IS: 11384 – 1985 : Code of Practice for Composite Construction in Structural Steel and Concrete.

## IV B. Tech. – I Semester

### (19BT70111) BRIDGE ENGINEERING

(Professional Elective - 5)

Int. Marks	Ext. Marks	Total Marks	L	T	P	C
40	60	100	3	--	--	3

**PRE-REQUISITES:** Engineering Mechanics, Mechanics of Solids, Structural Analysis, Reinforced Concrete Structures, Transportation Engineering, Engineering Hydrology and Foundation Engineering

**COURSE DESCRIPTION:** Bridge loading standards; Deck slab bridge; Box culvert; Beam and slab bridge; Bridge bearings; Piers and abutments.

**COURSE OUTCOMES:** On successful completion of this course, the students will be able to:

- CO1 Analyze bridge loading standards to solve bridge engineering problems following relevant codes ensuring safety besides communicating effectively in graphical form.
- CO2 Design deck slab bridge and box culvert to solve complex bridge engineering problems using appropriate techniques considering safety, serviceability, environment and IRC codes of practice besides communicating effectively in graphical form.
- CO3 Design beam and slab bridge to solve complex bridge engineering problems using appropriate techniques considering safety, serviceability, environment and IRC codes of practice besides communicating effectively in graphical form.
- CO4 Design bridge bearings to solve complex bridge engineering problems using appropriate techniques considering safety, serviceability, environment and IRC codes of practice besides communicating effectively in graphical form.
- CO5 Analyze piers, abutments and bridge foundations to solve bridge engineering problems considering safety, serviceability, environment and IRC codes of practice.

#### DETAILED SYLLABUS:

#### UNIT – I: BRIDGE LOADING STANDARDS (09 Periods)

Importance of site investigation in bridge design, Various loads in bridges, Highway bridge loading standards, Impact factor, Railway bridge loading standards.

#### UNIT – II: DECK SLAB BRIDGE AND BOX CULVERT (09 Periods)

**Deck Slab Bridge:** Effective width method of analysis and design of deck slab bridge (simply supported) subjected to Class AA tracked vehicle only.

**Box Culvert:** General aspects, Design loads, Design of box culvert subjected to class AA tracked vehicle only.

#### UNIT – III: BEAM AND SLAB BRIDGE (T-BEAM BRIDGE) (09 Periods)

General features, Design of interior panel of slab, Pigeauds method, Design of a T-beam bridge subjected to Class AA tracked vehicle only.

#### UNIT - IV: BRIDGE BEARINGS (09 periods)

General features, Types of bearings, Design principles of steel rocker and roller bearings, Design of a steel rocker bearing, Design of elastometric pad bearing.

#### UNIT – V: PIERS AND ABUTMENTS (09 Periods)



General features, Bed block, Materials of piers and abutments, Types of piers, Forces acting on piers, Stability analysis of piers, General features of abutments, Forces acting on abutments, Stability analysis of abutments, Types of wing walls, Approaches, Types of bridge foundations (excluding design).

**Total Periods: 45**

**Topics for self-study are provided in the lesson plan**

**TEXT BOOKS:**

1. Krishna Raju, N., *Design of Bridges*, CBS Publishers and Distributors Pvt Ltd, 5<sup>th</sup> Edition, 2019.
2. Ponnuswamy, S., *Bridge Engineering*, Tata Mcgraw–Hill Company, 3<sup>rd</sup> Edition, 2017.

**REFERENCE BOOKS:**

1. Jagadish, T. R. and Jayaram, M. A., *Design of Bridges Structures*, Prentice Hall of India Pvt. Ltd., 2<sup>nd</sup> Edition, 2009.
2. Bindra, S. P., *Principles and Practice of Bridge Engineering*, Dhanpat Rai Publishing Co Pvt Ltd, 2012.
3. Victor D. Johnson, *Essentials of Bridge Engineering*, Oxford & IBH Publishing Co Pvt. Ltd., 6<sup>th</sup> Edition, 2019.
4. Rangwala, *Bridge Engineering*, Charotar Publishing House Pvt. Ltd, 16<sup>th</sup> Edition, 2015.

**ADDITIONAL LEARNING RESOURCES:**

1. Aswani, M. G., Vazirani, V. N. and Ratwani, M. M., *Design of Concrete Bridges*, Khanna Publishers, 1995.
2. Krishna Raju, N., *Prestressed Concrete Bridges*, CBS Publishers, 1<sup>st</sup> Edition, 2016.

**Codes:**

IRC: 6:2017	: Loads and Load Combinations.
IRC: 112-2011	: Concrete Road Bridges.
IRC: 83(Part I):1999	: Bearings, Part I: Metallic Bearings.
IRC: 83(Part II):1987	: Bearings, Part II: Elastomeric Bearings.

## IV B.Tech. - I Semester

### (19BT70112) CIVIL INFRASTRUCTURE FOR SMART CITY DEVELOPMENT

(Professional Elective – 5)

Int. Marks	Ext. Marks	Total Marks	L	T	P	C
40	60	100	3	-	-	3

#### PRE-REQUISITES: -

**COURSE DESCRIPTION:** Smart cities; Urban planning for smart city; Smart city development; Smart buildings; Smart city mobility; Smart city utilities and services.

**COURSE OUTCOMES:** On successful completion of this course, the students will be able to:

- CO1. Analyze various elements of smart city infrastructure to solve complex problems following relevant policies considering health, safety, society, environment, sustainability and project management.
- CO2. Analyze urban planning to solve complex smart city problems following relevant standards by using appropriate tools and techniques considering society, environment and sustainability besides communicating effectively in graphical form.
- CO3. Analyze smart city development and smart buildings to solve complex problems using appropriate tools and techniques following relevant standards considering health, safety, environment, sustainability, economics and management.
- CO4. Analyze smart city mobility to solve complex smart city problems using appropriate tools and techniques following relevant policies considering safety, society, environment and sustainability.
- CO5. Analyze smart city utilities and services to solve complex smart city problems using appropriate tools and techniques considering health, society, environment, sustainability, economics and management.

#### DETAILED SYLLABUS:

##### UNIT – I: SMART CITIES

(08 Periods)

Smart City; Elements of Smart city infrastructure – Buildings, Mobility, Energy, Water, Waste management, Health and Digital layers; Need for an integrated approach; Role of science, technology and innovation in the implementation of smart infrastructure; Smart infrastructure design principles and policies; Case studies: Gujarat International Finance Tech-City in India.

##### UNIT – II: URBAN PLANNING FOR SMART CITY

(09 Periods)

Introduction to concepts of urban planning; Various levels – Development Plan, Regional Plan, Sub-city Plans; Provision of local needs; Importance of local area and neighborhood planning; Land use controls and zoning; Housing and slum rehabilitation; Urban patterns; Conservation of Natural and built heritage environment; Elements of urban design; Indian best practices in urban planning; Application of Remote Sensing (RS) for land use/land cover, agriculture and urban planning.

##### UNIT – III: SMART CITY DEVELOPMENT AND SMART BUILDINGS (10 Periods)

**Smart City Development:** Evolution and Concept; Objectives; Contemporary features; Relevance and Importance; Barriers and Drivers; Smart City Governance and Public Institutions; Sustainability and Resilience; Livability index; Smart city ranking index; Application of BIM in Smart city development.

**Smart Buildings:** Smart building; Siting the building; Materials; Measuring the Performance of a Building – Financial metrics, Security and life safety, Productivity

and satisfaction of building occupants; Essential attributes of a smart building – HVAC, Lighting control, Electric power management, Access control, Video surveillance, Fire alarm and mass notification; Design, Construction, and Renovation process; The Economics of smart buildings; Energy and sustainability; Case studies.

**UNIT – IV: SMART CITY MOBILITY (09 Periods)**

Introduction; Issues of urban transport; Demand and supply side solutions; Design concepts (pedestrian friendly/vehicle friendly design, safety considerations); Sustainable transportation; Urban transport planning process; Traffic operation policies; Intelligent Transportation System (ITS) for efficient utilization of resources; Components of ITS; Public transportation systems - Metro rail and Bus Rapid Transit System (BRTS); New trends in urban mobility; Case studies.

**UNIT – V: SMART CITY UTILITIES AND SERVICES (09 Periods)**

Sector wise issues in city infrastructure services such as water distribution; waste water collection; waste treatment; Tariff structures; Metering and billing; 24x7 water supply system; Urban sanitation; Integrated Water Resource Management System (IWRM); Smart city applications using RS & Geographic Information System (GIS) for water and waste water utilities; Street lighting system; Case studies.

**Total Periods: 45**

**Topics for self-study are provided in the lesson plan.**

**TEXT BOOKS:**

1. James Sinopoli, *Advanced Technology for Smart Buildings*, Artech House, 2016.
2. Sussman, J.S., *Perspectives on Intelligent Transportation Systems (ITS)*, Springer Science & Business Media, 2008.

**REFERENCE BOOKS:**

1. Geertman, S., Ferreira, J., Goodspeed, R. & Stillwell, J., *Planning Support Systems and Smart Cities*, Springer, 2015.
2. Vinodkumar, T.M., *Geographic Information System for Smart Cities*, Copal Publishing, 2014.
3. James M. Sinopoli, *Smart Buildings Systems for Architects, Owners and Builders*, Butterworth-Heinemann, 1<sup>st</sup> Edition, 2009.
4. Jha, R., Chandiramani, J., *Perspectives in Urban Development-Issues in Infrastructure, Planning and Governance*, Capital Publishing, New Delhi, 1<sup>st</sup> Edition, 2012.

**ADDITIONAL LEARNING RESOURCES:**

1. Khisty, C.J. and Lall, B.K., *Transportation Engineering*, Pearson Education India, 3<sup>rd</sup> Edition, 2017.
2. *Smart Cities Mission Statement & Guidelines*, Ministry of Urban Development Government of India, June 2015.
3. *Smart Cities and Infrastructure*, Commission on Science and Technology for Development, Nineteenth Session, United Nations Conference on Trade and Development, 09 - 13 May 2016, Room XVIII, Palais des Nations, Geneva, Switzerland.

## IV B.Tech. - I Semester

### (19BT70113) ENVIRONMENTAL IMPACT ASSESSMENT AND MANAGEMENT

(Professional Elective – 5)

Int. Marks	Ext. Marks	Total	L	T	P	C
40	60	100	3	-	-	3

**PREREQUISITES:** Courses on Environmental Science, Environmental Engineering.

**COURSE DESCRIPTION:** Environmental Impact Assessment; EIA methodologies; EIA on soil, groundwater and surface water; EIA on air, vegetation and wild life; Environmental acts and management system.

**COURSE OUTCOMES:** On successful completion of this course, the students will be able to:

- CO1. Analyze the environmental impact assessment to provide solutions to environmental problems using appropriate tools and techniques following relevant standards and regulations considering the society, health, safety, environment, sustainability and economics besides communicating effectively in graphical form.
- CO2. Analyze EIA methodologies to solve environmental problems following relevant standards, regulations and latest developments considering the society, health, safety, environment, sustainability and economics besides communicating effectively in graphical form.
- CO3. Analyze EIA on soil, groundwater and surface water to provide solutions to environmental problems using appropriate tools and techniques following relevant standards and regulations considering the society, health, safety, environment, sustainability and project management besides communicating effectively in graphical form.
- CO4. Analyze EIA on air, vegetation and wildlife to provide solutions to environmental problems using appropriate tools and techniques following relevant standards and regulations considering the society, health, safety, environment, sustainability and project management besides communicating effectively in graphical form.
- CO5. Analyze environmental acts and management system to solve complex environmental problems using appropriate tools and techniques following relevant standards, regulations and latest developments considering the society, health, safety, environment, sustainability and project management besides communicating effectively in graphical form.

#### DETAILED SYLLABUS:

##### **UNIT – I: ENVIRONMENTAL IMPACT ASSESSMENT (09 Periods)**

Basic concept of EIA, Introduction to life cycle analysis, Initial environmental examination, Elements of EIA, Factors affecting EIA, Impact evaluation and analysis, Preparation of environmental base map and classification of environmental parameters.

##### **UNIT – II: EIA METHODOLOGIES (08 Periods)**

Criteria for the selection of EIA Methodology; EIA Methods – Adhoc method, Matrix method, Network method, Environmental medium quality index method, Overlay method and Cost/benefit analysis, Latest developments.

##### **UNIT – III: EIA ON SOIL, GROUNDWATER AND SURFACE WATER (10 Periods)**

Soil and water quality, Impact assessment on soil – Delineation of study area, Identification of activities, Impact prediction, Assessment of impact significance, Identification and incorporation of mitigation measures; EIA on surface and ground

water - Methodology for the assessment of impacts on water environment, Identification and incorporation of mitigation measures, Watershed management.

**UNIT – IV: EIA ON AIR, VEGETATION AND WILDLIFE (09 Periods)**

Air pollution sources, generalized approach for assessment of impact due to air pollution caused by the various anthropogenic activities, Identification and incorporation of mitigation measures; Assessment of impact on vegetation and wildlife caused by the various developmental activities; Environmental impact due to deforestation – Causes and effects; Case studies.

**UNIT – V: ENVIRONMENTAL ACTS AND MANAGEMENT SYSTEM (09 Periods)**

Environmental Acts - Environmental protection act, The water act, The air act, Wild life act; Environmental management system – Objectives, Environmental audit, Types and Stages of environmental audit, Evaluation of audit data and preparation of audit report, Post audit activities, case studies.

**Total Periods: 45**

**Topics for self-study are provided in the lesson plan.**

**TEXT BOOKS:**

1. Anjaneyulu, Y., *Environmental Impact Assessment Methodologies*, B.S. Publications, 2<sup>nd</sup> Edition, 2007.
2. Khandeshwar, S.R., Raman, N.S., Gajbhiye, A.R., *Environmental Impact Assessment*, Wiley Publications, Wiley India Pvt. Ltd., Noida, 2019.

**REFERENCE BOOKS:**

1. Marriott, B., *Environmental Impact Assessment: A Practical Guide*, McGraw-Hill, New York, USA. 1997.
2. Charles H. Eccleston, *Environmental Impact Assessment*, CRC Press, Taylor and Francis Group, 2011.
3. Suresh K. Dhameja, *Environmental Engineering and Management*, S.K. Kataria and Sons, 2010.
4. Bhatia, H. S., *A Text Book of Environmental Pollution and Control*, Galgotia Publications (P) Ltd., 2003.

**ADDITIONAL LEARNING RESOURCES:**

1. Peavy, H.S., ROWE, D.R., Tchobanoglous, G., *Environmental Engineering*, McGraw-Hill Book Co., New Delhi, 1995.
2. John Glasson, Riki Therivel and Andrew Chadwick, *Introduction to Environmental Impact Assessment*, 3<sup>rd</sup> Edition, Routledge, London and New York, 2012.
3. Santosh Kumar Garg, *Sewage Disposal and Air Pollution Engineering*, Khanna Publishers, New Delhi, 27<sup>th</sup> Edition, 1<sup>st</sup> Reprint, 2013.
4. *Manual on Water Supply and Treatment*, CPHEEO, Government of India, New Delhi, 1999.
5. *Manual on Sewerage and Sewage Treatment*, CPHEEO, Govt. of India, New Delhi, 1993.

## IV B. Tech. – I Semester

### (19BT70114) GEOTECHNICS FOR UNDERGROUND STRUCTURES

(Professional Elective - 5)

Int. Marks	Ext. Marks	Total Marks	L	T	P	C
40	60	100	3	-	-	3

**PRE-REQUISITES:** - Courses on Soil Mechanics, Foundation Engineering.

**COURSE DESCRIPTION:** Underground structures and geotechnical investigations; Underground space planning and design; Failure criteria for soil and rock; Analysis and design of underground structures; Non-destructive testing and health monitoring.

**COURSE OUTCOMES:** On successful completion of this course, the students will be able to:

- CO1 Analyze underground structures and geotechnical investigations to solve complex problems associated with underground structures using appropriate tools and techniques by following the relevant codes of practice and latest developments considering safety, society, environment, sustainability and project management besides communicating effectively in graphical form.
- CO2 Design underground space and planning to solve complex problems associated with underground structures using appropriate techniques by following the relevant codes of practice considering safety, society, environment, sustainability and project management besides communicating effectively in graphical form.
- CO3 Analyze the failure criteria for soil and rock to solve complex problems associated with underground structures using appropriate techniques considering safety besides communicating effectively in graphical form.
- CO4 Design underground structures to solve complex problems associated with underground structures using appropriate techniques by following the relevant codes of practice considering safety, society, environment, sustainability and project management besides communicating effectively in graphical form.
- CO5 Analyze non-destructive testing and health monitoring of underground structures using appropriate techniques to solve complex problems by following the relevant codes of practice and latest developments considering safety, society, environment, sustainability and project management besides communicating effectively in graphical form.

#### **DETAILED SYLLABUS:**

#### **UNIT - I: UNDERGROUND STRUCTURES AND GEOTECHNICAL INVESTIGATIONS (09 Periods)**

Underground structures - Introduction, Necessity for underground construction, Types and applications of underground structures, Parameters for site selection, Laboratory and field tests of soil, Materials used in underground structures, Geoengineering; Investigations for rock or rock mass characterization - Topographical and geological survey, augering, drilling, soil and rock sampling and testing, Preparing subsurface geological cross section, Georadar use and data analysis for shallow tunnels, Geophysical investigations to identify deeper sub-surface features, Characterization of ground profile.

## **UNIT – II: UNDERGROUND SPACE PLANNING AND DESIGN (09 Periods)**

Determination of appropriate location, size, shape and alignment; Assessment of behaviour of tunnelling media - Deformation modulus and support pressure measurement, Application of numerical modelling in space design, Earthquake effects on tunnels, Design of underground space in rocks with the help of field data; Design of underground openings - Design based on empirical methods such as RSR, RMR, Q systems, Design based on Rock support interaction analysis; Observational methods - NATM, Convergence - confinement method, Key block analysis; Stability of excavation face and tunnel portals.

## **UNIT – III: FAILURE CRITERIA FOR SOIL AND ROCK (09 Periods)**

Failure theories - Failure criteria for soil and rock masses, Mohr-Coulomb yield criterion, Hoek-Brown criterion, Tensile yield criterion, Jointed rock yield criterion, Hardening soil criterion, Strength of discontinuities.

## **UNIT – IV: ANALYSIS AND DESIGN OF UNDERGROUND STRUCTURES (09 Periods)**

Beam on elastic foundation method, Stress based analysis, Deformation-based analysis, Soil-structure interaction, Analysis of geotechnical structures using Boundary element method, finite element method, Rankine's and Coulomb's earth pressure theory, Earth pressure for design of excavation, Design of box culvert structures, Design of foundation pit retaining walls.

## **UNIT – V: NON-DESTRUCTIVE TESTING AND HEALTH MONITORING (09 Periods)**

Strain integrity testing, Cross hole sonic tests, Health monitoring of underground structures, Use of sensors, Vibrating wire displacement sensor, Potentiometric displacement sensor, inclinometer/in place-inclinometer, Wireless tilt meter, Data loggers – Measurement and interpretation of test data.

**Total Periods: 45**

**Topics for self-study are provided in the lesson plan.**

### **TEXT BOOKS:**

1. Zhen-Dong Cui, Zhong-Liang Zhang, Li Yuan, Zhi-Xiang Zhan and Wan-Kai Zhang, *Design of Underground Structures*, Springer, 2020.
2. Pietro Lunardi, *Design and Construction of Tunnels*, Springer, 2008.

### **REFERENCE BOOKS:**

1. Sinha, R.S., *Underground Structures: Design and Instrumentation*, Elsevier Science Publisher, 1989.
2. Bai Yun., *Underground Engineering: Planning, Design, Construction and Operation of the Underground Space*, Academic Press, 2019.
3. Goel, R.K., Singh, B., Zhao, J., *Underground Infrastructures: Planning, Design and Construction*, Elsevier, 2012.

### **ADDITIONAL LEARNING RESOURCES:**

1. John A Hudson and John P Harrison, *Engineering Rock Mechanics: An Introduction to the Principles*, Elsevier Science and Technology, 2000.
2. Richard E. Goodman, *Introduction to Rock Mechanics*, John Wiley and Sons, 2<sup>nd</sup> Edition, 1989.
3. Bieniawski, Z.T., *Rock Mechanics Design in Mining and Tunneling*, A.A. Balkema, 1984.
4. Obert, L. and Duvall, W.I., *Rock Mechanics and the Design of Structures in Rock*, Wiley, 1967.
5. Bieniawski, Z.T., *Engineering Rock Mass Classifications: A Complete Manual for Engineers and Geologists in Mining, Civil, and Petroleum Engineering*, Wiley, 1989.

6. Sherif, A., Piergiorgio, G., *Engineering Challenges for Sustainable Underground Use*, Proceedings of the 1<sup>st</sup> GeoMEast International Congress and Exhibition, Egypt, 2017.



## IV B. Tech. – I Semester

### (19BT70115) **TRAFFIC ENGINEERING AND MANAGEMENT**

(Professional Elective-5)

Int. Marks	Ext. Marks	Total Marks	L	T	P	C
40	60	100	3	--	--	3

**PRE-REQUISITES:** Course one Transportation Engineering.

**COURSE DESCRIPTION:** Traffic engineering; Traffic characteristics; Traffic studies; Parking studies; Highway capacity; Highway safety; Traffic signs and road markings; Traffic and environment; Traffic control, regulation and Traffic management.

**COURSE OUTCOMES:** On successful completion of this course, the students will be able to:

- CO1 Analyze traffic and traffic characteristics to solve complex traffic engineering problems using appropriate techniques following relevant codes considering society and environment besides communicating effectively in graphical form.
- CO2 Analyze traffic measurements to solve complex traffic engineering problems using appropriate techniques following relevant codes considering society and environment besides communicating effectively in graphical form.
- CO3 Analyze highway capacity and safety to solve complex traffic engineering problems using appropriate techniques following relevant codes considering environment besides communicating effectively in graphical form.
- CO4 Analyze traffic signs, road markings; traffic and environment to solve complex traffic engineering problems using appropriate techniques following relevant standards considering safety besides communicating effectively in graphical form.
- CO5 Analyze traffic control, regulation and management to solve complex traffic engineering problems using appropriate techniques following relevant standards and latest developments considering society and environment besides communicating effectively in graphical form.

#### **DETAILED SYLLABUS:**

#### **UNIT – I: TRAFFIC ENGINEERING AND TRAFFIC CHARACTERISTICS (9 Periods)**

**Traffic Engineering:** Significance and scope; Characteristics of vehicles and road users; Skid resistance and braking efficiency (Problems); Components of traffic engineering - Road, traffic and land use characteristics.

**Traffic Characteristics:** Basic characteristics of traffic - volume, speed and density; Relationship among traffic parameters; Temporal headway and spatial headway; Vehicular speed trajectories; Car-following and lane change theories - Macroscopic flow models, Microscopic flow models; Shockwave analysis with examples.

#### **UNIT-II: TRAFFIC MEASUREMENTS (9 Periods)**

**Traffic Studies:** Traffic volume studies - Objectives, Types of volume studies, Concept of PCU, Data collection and presentation; Speed studies - Types of speeds, Objectives of speed studies, Methods of conducting speed studies, Data collection and presentation, Statistical methods for analysis of speed data; Origin and destination studies, Pedestrian studies, Basic principles of traffic flow.

**Parking Studies:** Types of parking facilities, On-street and off-street parking facilities, Parking inventory study, Parking survey by patrolling method, Analysis of parking data and parking characteristics, Multi storey car parking facility, Design standards.

**UNIT-III: HIGHWAY CAPACITY AND SAFETY (9 Periods)**

**Highway Capacity:** Definition of capacity, Importance of capacity, Factors affecting capacity, Concept of level of service, Different levels of service, Concept of service volume, Peak hour factor.

**Highway Safety:** Problem of highway safety, Types of road accidents, Causes, Engineering measures to reduce accidents, Enforcement measures, Educational measures, Road safety audit, Principles of road safety audit.

**UNIT-IV: TRAFFIC SIGNS, ROAD MARKINGS, TRAFFIC AND ENVIRONMENT (9 Periods)**

**Traffic Signs and Road Markings:** Types of traffic signs; Cautionary, regulatory and informative signs; Specifications, Pavement markings, Types of markings, Lane markings and object markings, Standards and specifications for road markings.

**Traffic and Environment:** Detrimental effect of traffic on environment, Air pollution, Pollutants due to traffic, Measures to reduce air pollution due to traffic, Noise pollution, Measures to reduce noise pollution.

**UNIT-V: TRAFFIC CONTROL, REGULATION AND MANAGEMENT (9 Periods)**

**Traffic Control and Regulation:** Traffic problems in urban areas, Importance of traffic control and regulation, Traffic regulatory measures, Channelization; Principle and design of intersections, grade separations and interchanges; Traffic signals, Saturation flow, Design of traffic signals and signal co-ordination (Problems), Signal phasing and timing diagrams, Traffic control aids and street furniture, Street lighting, Computer applications in signal design.

**Traffic Management:** Transportation system management (TSM), Travel demand management (TDM), Traffic forecasting techniques, restrictions on turning movements, One-way Streets, Traffic segregation, Traffic calming, Tidal flow operations, Exclusive bus lanes, Introduction to intelligent transportation system (ITS).

**Total Periods: 45**

**Topics for self-study are provided in the lesson plan.**

**TEXT BOOKS:**

1. Kadiyali, L. R., *Traffic Engineering and Transport Planning*, Khanna Publishers, New Delhi, 9<sup>th</sup> Edition, 1999.
2. Khanna, K. and Justo, C. E. G., *Highway Engineering*, Nem Chand & Bros, 8<sup>th</sup> Edition, 2009.

**REFERENCE BOOKS:**

1. Roger Roess, P. Elena, S. Prassas and William, R. Shane, M. C., *Traffic Engineering*, Prentice Hall, 4<sup>th</sup> Edition, 2010.
2. Chakroborthy, P. and Das, A., *Principles of Transportation Engineering*, Prentice Hall of India Pvt. Ltd, 2<sup>nd</sup> Edition, 2017.
3. Subhash, C. and Saxena, A., *Course in Traffic Planning and Design*, Dhanpat Rai Publications, 2010.
4. JotinKhisty, C. and KentLall, B., *Transportation Engineering – An Introduction*, Prentice Hall of India Pvt. Ltd., 3<sup>rd</sup> Edition, 2002.

**ADDITIONAL LEARNING RESOURCES:**

1. Papacostas, C. S. and Prevedouros, P. D., *Transportation Engineering and Planning*, PearsonIN, 3<sup>rd</sup> Edition, 2015.
2. Fred L Mannering and Scott S Washburn, *Principles of Highway Engineering and Traffic Analysis*, Wiley, 7<sup>th</sup> Edition, 2019.

3. Indian Roads Congress (IRC) Specifications: *Guidelines and Special Publications on Traffic Planning and Management.*
4. *Guidelines of Ministry of Road Transport and Highways, Government of India.*

## IV B.Tech. – I Semester

### (19BT70116) WATER RESOURCES SYSTEMS PLANNING AND MANAGEMENT

(Professional Elective–5)

Int. Marks	Ext. Marks	Total Marks	L	T	P	C
40	60	100	3	-	-	3

**PREREQUISITES:** Courses on Surveying, Engineering Hydrology, Irrigation Engineering.

**COURSE DESCRIPTION:** Concepts of Water resources systems; Linear programming; Dynamic programming; Non-linear optimization techniques and simulation; Water resources economics and management.

**COURSE OUTCOMES:** On successful completion of this course, the students will be able to:

- CO1 Analyze systems approach to water resources to solve complex water resources engineering problems using appropriate tools and techniques considering society, environment, sustainability and project management.
- CO2 Formulate linear programming models to solve complex water resources engineering problems using appropriate tools and techniques considering society, environment, sustainability and project management.
- CO3 Formulate dynamic programming models to solve complex water resources engineering problems using appropriate tools and techniques considering society, environment, sustainability and project management.
- CO4 Analyze non-linear optimization and simulation techniques in water resources planning to solve complex water resources engineering problems considering society, environment and sustainability.
- CO5 Analyze various water resources economics to solve complex water resources engineering problems for sustainable water resources planning and management following ethics considering society, environment and management.

#### DETAILED SYLABUS:

#### UNIT - I: WATER RESOURCE SYSTEMS

(09 Periods)

Concepts of systems analysis, Systems approach to water resources planning and management, Role of optimization models, Objective function and constraints, Types of optimization techniques.

#### UNIT - II: LINEAR PROGRAMMING

(09 Periods)

Formulation of linear programming models, Graphical method, Simplex method, Application of linear programming in water resources, Revised simplex method, Duality in linear programming, Sensitivity and post optimality analysis.

#### UNIT - III: DYNAMIC PROGRAMMING

(09 Periods)

Belman's principles of optimality, Forward and backward recursive dynamic programming, Case of dimensionality, Application of dynamic programming for resource allocation.

#### UNIT - IV: NON-LINEAR OPTIMIZATION TECHNIQUES AND SIMULATION

(08 Periods)

Classical method of optimization, Kun-Tucker, Gradient based techniques for simple unconstrained optimization, Application of simulation techniques in water resources planning.

**UNIT - V: WATER RESOURCES ECONOMICS AND MANAGEMENT (10 Periods)**

Principles of economic analysis, Benefit cost analysis, Socio-economic institutional and pricing of water resources, Planning of reservoir system, Optimal operation of single reservoir system, Allocation of water resources, Optimal cropping pattern, Conjunctive use of surface and sub-surface water resources, Case studies.

**Total Periods: 45**

**Topics for self-study are provided in the lesson plan.**

**TEXT BOOKS:**

1. Vedula, S., and Mujumdar, P. P., *Water Resources Systems*, Tata McGraw-Hill, 5<sup>th</sup> Edition, 2010.
2. Ramanathan, N., *Operations Research*, TMH Publications, 2005.

**REFERENCE BOOKS:**

1. Bhave, P. R., *Optimal Design of Water Distribution Networks*, Narosa Publishing House, 2003.
2. Sankar Iyer, P., *Operations Research*, TMH Publications, 2008.
3. Rao, S. S., *Engineering Optimization*, John Wiley and Sons Inc., 4<sup>th</sup> Edition, 2009.
4. James and Lee, *Water Resources Economics*, Oxford Publishers, 2005.
5. Jain, S. K., and Singh, V. P., *Water Resources Systems Planning and Management*, Elsevier, Netherlands, 2003.

**ADDITIONAL LEARNING RESOURCES:**

1. Loucks, D. P., and Beek, E. V., *Water Resources Systems Planning and Management*, UNESCO Publishing, Netherland, 2005.
2. Chadurvedi, M. C., *Water Resource Systems Planning and Management*, Tata McGraw Hill inc., New Delhi, 1997.

## IV B. Tech. – I Semester

### (19BT70131) REMOTE SENSING AND GEOGRAPHICAL INFORMATION SYSTEMS LAB

Int. Marks	Ext. Marks	Total Marks	L	T	P	C
50	50	100	-	-	2	1

**PRE-REQUISITES:** Course on Surveying

**COURSE DESCRIPTION:** Creation of geo-database; Georeferencing and projection; Digitization of toposheet/map; Editing map elements; Spatial analysis tools; Developing digital elevation model; Preparation of thematic maps; Land use and land cover analysis; Study of feature estimation; Watershed analysis; Road network analysis; Rainfall-runoff analysis.

**COURSE OUTCOMES:** After successful completion of this course, the students will be able to:

- CO1 Analyze toposheets, aerial photographs and satellite imagery to solve complex civil engineering problems using remote sensing and GIS tools following relevant standards and latest developments considering society, environment and sustainability.
- CO2 Develop thematic maps for land use land cover, feature estimation, watershed management, road network and rainfall-runoff to solve complex civil engineering problems using remote sensing and GIS tools following relevant standards and latest developments considering society, environment and sustainability.
- CO3 Perform individually or in a team besides communicating effectively in written, oral and graphical forms on remote sensing and GIS applications in civil engineering.

#### **DETAILED SYLLABUS:**

##### **LIST OF EXERCISES:**

1. Creation of geo-database
2. Georeferencing and projection
3. Digitization of toposheet/map
4. Editing Map Elements
5. Spatial Analysis Tools
6. Developing digital elevation model
7. Preparation of thematic maps
8. Landuse and landcover analysis
9. Study of feature estimation
10. Watershed analysis
11. Road network analysis
12. Rainfall-runoff analysis

##### **REFERENCE BOOKS/LABORATORY MANUALS:**

1. *Remote Sensing and GIS Laboratory Manual (SVEC19 Regulations)*, Department of Civil Engineering, Sree Vidyanikethan Engineering College, Tirupati.
2. Lilles and, T. M., Kiefer, R. W. and J. W. Chipman, *Remote Sensing and Image Interpretation*, John Willey and Sons (Asia) Pvt. Ltd. 7<sup>th</sup> Edition, 2014.
3. Chandra, A. M. and Ghosh, S. K., *Remote Sensing and Geographic Information System*, Narosa Publishing House, 2<sup>nd</sup> Edition, 2015.

**SOFTWARE/Tools used:** ArcGIS.

## IV B.Tech. – I Semester

### (19BT70132) COMPUTER AIDED DESIGN AND DETAILING LAB

Int. Marks	Ext. Marks	Total Marks	L	T	P	C
50	50	100	-	-	2	1

**PRE-REQUISITES:** Courses on Structural Analysis, Reinforced Cement Concrete Structures, Steel Structures, Advanced RCC, Advanced Steel Structures.

**COURSE DESCRIPTION:** Exercises on Analysis and design of Simple beams; 2-D and 3-D RCC Frames; Trusses; Solid slabs; Retaining walls; Water tanks; Plate Girder Bridges.

**COURSE OUTCOMES:** On successful completion of this course, the students will be able to:

- CO1 Design RCC structures and structural elements to solve complex structural engineering problems using appropriate software tools and techniques following relevant IS Codes considering safety and serviceability.
- CO2 Design steel structures to solve complex structural engineering problems using appropriate software tools and techniques following relevant IS Codes considering safety and serviceability.
- CO3 Perform individually or in a team besides communicating effectively in written, oral and graphical forms on computer aided structural design and detailing.

#### DETAILED SYLLABUS:

**SOFTWARE:** STAAD.Pro or any other industry popular structural analysis and design softwares.

#### LIST OF EXERCISES

1. Analysis and design of simple beams
  - a) Simply supported beam
  - b) Cantilever beam
  - c) Continuous beam
  - d) Fixed beam
2. 2-D RCC Frame analysis and design
3. 3-D RCC Frame analysis and design
4. Analysis and design of Steel Truss
  - a) Howe roof truss
  - b) Howe bridge truss
  - c) Warren truss
  - d) Pratt truss
5. Simple tower analysis and design
6. Analysis and design of solid slab
7. Retaining wall analysis and design
8. Design of RCC Tee beam bridges for IRC loading
9. Analysis and design of INTZ type water tank
  - a) Circular water tanks
  - b) Rectangular water tanks
10. Analysis and design of plate girder bridge

#### TEXT BOOKS:

1. Shah, V. L., and Karve., S. R., *Illustrated Design of Reinforced Concrete Building, Structures Publication, Pune, 7<sup>th</sup> Edition, 2014.*

2. Krishnamurthy. D., *Structural Design and Drawing*, Vol-II and Vol-III, CBS Publishers and Distributors, Delhi, 2006.

**REFERENCE BOOKS:**

1. *Computer Aided Design and Detailing Lab* (SVEC19 Regulations), Department of Civil Engineering, Sree Vidyanikethan Engineering College, Tirupati.

**CODES:**

- IS 456 – 2000 : Plain and Reinforced Concrete, Bureau of Indian Standards, New Delhi  
IS 800 – 2007 : General Construction in Steel, Bureau of Indian Standards, New Delhi.  
SP-16 – 1980 : Design Aids for Reinforced Concrete, Bureau of Indian Standards, New Delhi.  
SP-34 – 1987 : Hand Book on Concrete Reinforcement and Detailing, Bureau of Indian Standards, New Delhi.



**IV B.Tech. - I semester**  
**(19BT70133) INTERNSHIP**

Int. Marks	Ext. Marks	Total Marks	L	T	P	C
-	100	100	-	-	-	2

**PREREQUISITES: -**

**COURSE DESCRIPTION:** Expose students to the industrial environment; Create competent professionals for the industry; sharpen the real time technical / managerial skills required at the job; Gain professional experience and understand engineer's responsibilities and ethics; Familiarize with latest equipment, materials and technologies; Gain exposure to technical report writing; Gain exposure to corporate working culture.

**COURSE OUTCOMES:** After successful completion of the course, the students will be able to:

- CO1 Analyze latest equipment, materials and technologies that are used in industry to solve complex engineering problems following relevant standards, codes, policies and regulations.
- CO2 Analyze safety, health, societal, environmental, sustainability, economical and managerial factors considered in industry in solving complex engineering problems.
- CO3 Perform individually or in a team besides communicating effectively in written, oral and graphical forms on practicing engineering.

## IV B. Tech. – I Semester

### (19BT701AC) SPREAD SHEET APPLICATIONS IN CIVIL ENGINEERING

Int. Marks	Ext. Marks	Total Marks	L	T	P	C
			-	-	2	-

**PRE-REQUISITES:** MS Excel; Knowledge on Civil Engineering Courses.

**COURSE DESCRIPTION:** MS Excel as a spreadsheet tool; Spreadsheet creation; Design of slabs, Footings; Analysis of frames; Design of notches, Weirs; Design of pipes; Design of pavements.

**COURSE OUTCOMES:** On successful completion of this course, the students will be able to:

- CO1 Apply the principles of spreadsheet for the formation of cells, formatting and creation of tables following latest developments.
- CO2 Design structures and structural components to solve complex structural engineering problems using spreadsheet tool following relevant codes considering safety, serviceability, environment, sustainability and cost effectiveness.
- CO3 Design footings and pavements to solve complex geotechnical engineering and pavement engineering problems using spreadsheet tool following relevant codes considering safety, serviceability, environment, sustainability and cost effectiveness.
- CO4 Design water resources and environmental engineering systems to solve complex engineering problems using spreadsheet tool following relevant codes considering safety, serviceability, environment, sustainability and cost effectiveness.
- CO5 Perform individually or in a team besides communicating effectively in written, oral and graphical forms on spread sheet applications in civil engineering.

#### **DETAILED SYLLABUS:**

This laboratory provides training to the students in using MS Excel as a spreadsheet tool for various Civil Engineering Applications as mentioned below.

#### **LIST OF EXERCISES:**

1. Introduction to MS Excel as a Spreadsheet tool, overview of toolbars, accessing, saving excel files, using help and resources. Creating a spreadsheet using the features: Gridlines, format cells, summation, auto fill, formatting text, formulae in excel charts.
2. Creating a spreadsheet using the features: Split cells, Sorting, Conditional formatting, freeze panes, pivot tables, data validation.
3. Design of singly reinforced beam
4. Design of doubly reinforced beam
5. Design of one-way slab
6. Design of two-way slab
7. Design of isolated footings
8. Design of frames
9. Design of surplus weir
10. Design of trapezoidal notch
11. Design of canal regulator
12. Design of sewer pipe
13. Design of sewage treatment plant
14. Design of pavement

**TEXT BOOKS:**

1. Sylvan Charles Bloch, *Excel for Engineers and Scientists in Geotechnical Engineering*, Wiley, 2002.
2. Craig T. Christy, *Engineering with the Spreadsheet: Structural Engineering Templates using Excel*, ASCE Publications, 2006.

**REFERENCE BOOKS:**

1. Thomas F. Wolff, *Spreadsheet Applications in Geotechnical Engineering*, 1<sup>st</sup> Edition, PWS Publishing Company, 1995.

**CODES:**

- IS 456 – 2000 : *Plain and Reinforced Concrete*, Bureau of Indian Standards, New Delhi.
- IS 800 – 2007 : *General Construction in Steel*, Bureau of Indian Standards, New Delhi.
- SP-16 – 1980 : *Design Aids for Reinforced Concrete*, Bureau of Indian Standards, New Delhi.
- SP-34 – 1987 : *Hand Book on Concrete Reinforcement and Detailing*, Bureau of Indian Standards, New Delhi.

**IV B.Tech. - II semester**  
**(19BT80131) PROJECT WORK**

Int. Marks	Ext. Marks	Total Marks	L	T	P	C
100	100	200	-	-	-	10

**PREREQUISITES: -**

**COURSE DESCRIPTION:** Identification of topic for the project work; Literature survey; Collection of preliminary data; Identification of implementation tools and methodologies; Performing critical study and analysis of the topic identified; Time and cost analysis; Implementation of the project work; Preparation of thesis and presentation.

**COURSE OUTCOMES:** On successful completion of the course, the students will be able to:

- CO1 Create/Design civil engineering systems or processes to solve complex civil engineering and allied problems using appropriate tools and techniques following relevant standards, codes, policies, regulations and latest developments.
- CO2 Consider society, health, safety, environment, sustainability, economics and project management in solving complex civil engineering and allied problems.
- CO3 Perform individually or in a team besides communicating effectively in written, oral and graphical forms on civil engineering systems or processes.

**HONORS DEGREE**  
**IN**  
**CIVIL ENGINEERING**  
**(SVEC-19 Regulations)**

## **HONORS DEGREE IN CIVIL ENGINEERING**

### **COURSE STRUCTURE**

Year & Semester	Course Code	Course Title	Contact Periods per week				C	Scheme of Examination Max. Marks		
			L	T	P	Total		Int. Marks	Ext. Marks	Total Marks
III B.Tech. I-Sem (2 Theory)	19BT40107	Sustainable Engineering	3	-	-	3	3	40	60	100
	19BT50110	Ecology and Environmental Impact	3	-	-	3	3	40	60	100
	19BT50111	Waste to Energy	3	-	-	3	3	40	60	100
III B.Tech. II-Sem (2 Theory)	19BT60126	Environmental Sustainability	3	-	-	3	3	40	60	100
	19BT60127	Sustainable Energy Systems	3	-	-	3	3	40	60	100
	19BT60128	Sustainability in The Built Environment	3	-	-	3	3	40	60	100
IV B.Tech. I-Sem (2 Theory)	19BT70117	Environmental Economics	3	-	-	3	3	40	60	100
	19BT70118	Sustainable Cities	3	-	-	3	3	40	60	100
	19BT70119	Sustainable Design of Technology Systems	3	-	-	3	3	40	60	100

**Note:** If any student has chosen a course from the above list in their regular curriculum then, he/she is not eligible to opt the same course/s for the Honors degree. It is the responsibility of the student to acquire/complete prerequisite before taking the respective course.

### III B.Tech. - I Semester

#### (19BT40107) SUSTAINABLE ENGINEERING

Int. Marks	Ext. Marks	Total Marks	L	T	P	C
40	60	100	3	-	-	3

#### PRE-REQUISITES: -

**COURSE DESCRIPTION:** Principles of sustainability; Sustainability metrics and assessment tools; Sustainable engineering practices; Sustainable engineering applications; Sustainable urbanization and industrialization.

**COURSE OUTCOMES:** On successful completion of the course, students will be able to:

- CO1. Analyze the principles of sustainability to solve complex environmental problems following relevant standards/protocols considering society, health, safety and environment.
- CO2. Analyze sustainability metrics and assessment tools to solve complex environmental problems following relevant standards and emerging trends considering society, health, safety, environment and economics besides communicating effectively in graphical form.
- CO3. Analyze sustainable engineering practices to solve complex environmental problems using appropriate tools and techniques following relevant standards considering society, health, safety, environment, economics and management besides communicating effectively in graphical form.
- CO4. Design sustainable engineering applications to solve complex environmental problems using appropriate tools and techniques following relevant standards considering society, health, safety, environment, economics and management besides communicating effectively in graphical form.
- CO5. Analyze sustainable urbanization and industrialization principles to solve complex environmental problems using appropriate tools and techniques following relevant standards considering society, health, safety, environment, economics and management besides communicating effectively in graphical form.

#### DETAILED SYLLABUS:

##### UNIT - I: PRINCIPLES OF SUSTAINABILITY (09 Periods)

Emerging challenges, Sustainability and sustainable engineering; Environmental concerns; Social, economic and legal issues; Availability and depletion of natural resources, Disaster resiliency; Multilateral environmental agreements – Basel convention, Clean development mechanism (CDM), Montreal and Kyoto protocols.

##### UNIT – II: SUSTAINABILITY METRICS AND ASSESSMENT TOOLS (09 Periods)

Sustainability indicators, metrics and assessment tools, Material flow analysis and material budget, Carbon footprint analysis, Life cycle assessment, Streamlined life-cycle assessment (SLCA), Economic input output-life cycle analysis, Environmental health risk assessment, Other emerging assessment tools.

##### UNIT - III: SUSTAINABLE ENGINEERING PRACTICES (09 Periods)

Sustainable energy engineering, Sustainable waste management, Green and sustainable buildings and infrastructure, Sustainable civil infrastructure, Sustainable remediation of contaminated sites, Climate geoengineering.

#### **UNIT - IV: SUSTAINABLE ENGINEERING APPLICATIONS (09 Periods)**

Environmental and chemical engineering projects, Materials engineering projects, Infrastructure engineering projects – Background, Methodology, Goal and Scope, Study area, Technical design, Environmental sustainability, Life cycle assessment, Economic sustainability, Social sustainability, Rating systems – ENVISION, LEED, GRIHA, IGBC; Conclusions.

#### **UNIT – V: SUSTAINABLE URBANIZATION AND INDUSTRIALIZATION (09 Periods)**

Sustainable urbanization and industrialization, United Nations sustainable development goals – Right to education, Poverty eradication, Social and technological changes; Industrial Processes - Material selection, Energy efficiency, Pollution prevention and control techniques, Industrial Ecology, Industrial symbiosis.

**Total Periods: 45**

**Topics for self-study are provided in the lesson plan.**

#### **TEXT BOOKS:**

1. Reddy, K. R., Cameselle, C., and Adams, J. A., *Sustainable Engineering: Drivers, Metrics, Tools, and Applications*, John Wiley & Sons, Inc., Hoboken, New Jersey, 2019,
2. Allen, D. T. and Shonnard, D. R., *Sustainability Engineering: Concepts, Design and Case Studies*, Pearson Education, 1<sup>st</sup> Edition, 2012.

#### **REFERENCE BOOKS:**

1. Bradley. A. S; Adebayo, A. O., Maria, P., *Engineering Applications in Sustainable Design and Development*, Cengage Learning, 1<sup>st</sup> Edition, 2016.
2. Purohit, S. S., *Green Technology: An Approach for Sustainable Environment*, Agrobios Publication, 1<sup>st</sup> Edition, 2016.
3. *Energy Conservation Building Code (ECBC) 2007*, Bureau of Energy Efficiency, Govt. of India, New Delhi.
4. Twidell, J. W. and Weir, A. D., *Renewable Energy Resources*, Routledge, Taylor & Francis Group, 3<sup>rd</sup> Edition, 2015.

#### **ADDITIONAL LEARNING RESOURCES:**

1. Daniel A. Vallero and Chris Brasier, *Sustainable Design: The Science of Sustainability and Green Engineering*, Wiley-Blackwell, 1<sup>st</sup> Edition, 2008.
2. Jorge A. Vanegas, *Sustainable Engineering Practice: An Introduction*, Committee on Sustainability, American Society of Civil Engineers, <https://doi.org/10.1061/9780784407509>, 2004.
3. Mackenthun, K. M., *Basic Concepts in Environmental Management*, CRC Press, Taylor & Francis Group, 1<sup>st</sup> Edition, 1999.
4. *Environment Impact Assessment Guidelines*, Notification of Government of India, 2006.



### III B.Tech. - I Semester

#### (19BT50110) **ECOLOGY AND ENVIRONMENTAL IMPACT**

Int. Marks	Ext. Marks	Total Marks	L	T	P	C
40	60	100	3	-	-	3

**PREREQUISITES:** Course on Environmental Science

**COURSE DESCRIPTION:** Ecology; Ecosystem; Ecological impact assessment, Ecotoxicology and bio-monitoring, Restoration ecology.

**COURSE OUTCOMES:** *On successful completion of this course, the students will be able to:*

- CO1 Demonstrate the basic knowledge on ecology to provide solutions to environmental problems using appropriate tools and techniques considering society, health, environment and sustainability besides communicating effectively in graphical form.
- CO2 Analyze the ecosystems to solve environmental problems using appropriate tools and techniques considering society, health, safety, environment and sustainability besides communicating effectively in graphical form.
- CO3 Analyze the ecological impact assessment to solve complex environmental problems using appropriate tools and techniques following relevant standards and norms considering society, health, safety, environment, sustainability and economics besides communicating effectively in graphical form.
- CO4 Analyze the eco-toxicology effects and bio-monitoring of ecosystems to solve complex environmental problems using appropriate tools and techniques following relevant standards and norms considering society, health, safety, environment, sustainability and project management besides communicating effectively in graphical form.
- CO5 Analyze ecology of disturbed ecosystems, reconstructions and restoration of natural ecosystems to solve complex environmental problems following relevant standards and latest developments considering society, health, safety, environment, sustainability and project management besides communicating effectively in graphical form.

#### **DETAILED SYLLABUS:**

##### **UNIT - I: ECOLOGY (10 Periods)**

Scope, concept and multidisciplinary nature of ecology; Organizational level of ecological systems, Abiotic and biotic environment, Limiting factors, Adaptation, Habitat and niche, Holocoenotic nature of environment, Concept of biosphere; Landscape, population and community ecology; Synecological principles, Species area relations, Methods of sampling and describing plant community, Ecological succession, Succession models, Concept of climax.

##### **UNIT - II: ECOSYSTEM (8 Periods)**

Structure and function of ecosystems, Productivity, Decomposition, Energy flow, Ecological efficiencies, Ecological pyramids, Global pattern of productivity, Nutrient cycling (Carbon, Nitrogen and Phosphorus), Ecosystem stability – Inertia, Resilience; Fragile ecosystem, Hot spots, Ecosystem services, Net Present Value (NPV) of ecosystems, Major biomes of India and the world.

##### **UNIT - III: ECOLOGICAL IMPACT ASSESSMENT (09 Periods)**

Principles and practices of ecological assessment, Carrying capacity of environment and earth, Environmental quality, Ecological and social impact of man, Resource depletion, Loss of biological diversity, Land degradation and deforestation, Impact assessment methods through case studies at organism, Community and ecosystem levels, Detailed criteria, Survey methods and evaluation, Cost benefit analysis, Prediction of impacts on physical environment and biotic communities through modelling, Developing impact statement.

#### **UNIT - IV: ECOTOXICOLOGY AND BIO-MONITORING (08 Periods)**

**Ecotoxicology:** Ecotoxicology - Background, importance and measurement; LC50, EC50, NOEC, LOEC, Toxic units, Ecosystem response to de-oxygenation; Eutrophication - Kinetics, Lake phosphorous model, Pesticides.

**Bio-monitoring:** Bio-monitoring, Active and passive monitoring, Concept of bioaccumulation, Bio-indicator parameters, Bio-air conditioning and bio-purifiers, Pollution tolerance index of plants, Green belt development, Plant protection and protective substances to pollution stress, Data-gathering techniques, Organization of the survey and data analysis.

#### **UNIT - V: RESTORATION ECOLOGY (10 Periods)**

Ecological theories and principles that guide restoration practices in a variety of ecosystems, Causes of ecosystem degradation, Motivations for restoration, Factors that influence success in restoration; Ecology of disturbed ecosystems - Disturbance and its impact on the structure and functioning of terrestrial and aquatic ecosystems; Aims and strategies of restoration - Concepts of restoration, Single vs. multiple end-points, Ecosystem reconstructions, Physical, chemical, biological and biotechnological tools of restoration; Restoration of biological diversity - Acceleration of ecological succession, Reintroduction of biota; Degradation and restoration of natural ecosystems - Rivers, Wetlands, Forests, Grassland, Savanna, Aquatic; Restoration of degraded soils - Restoration of contaminated soils and soil fertility, Mine spoil restoration.

**Total Periods: 45**

**Topics for self-study are provided in the lesson plan.**

#### **TEXT BOOKS:**

1. Saha, T. K., *Ecology and Environmental Biology*, Books and Allied (P) Ltd., Kolkata, 1<sup>st</sup> Edition, 2010.
2. Walker, C. H., Hopkin, S. P., Sibly R. M. and Peakall, D. B., *Principles of Ecotoxicology*, Taylor and Francis Group, London, 2<sup>nd</sup> Edition, 2004.
3. Palmer, M. A., Zedler, J. B. and Falk, D. A., *Foundations of Restoration Ecology*, Island Press, USA, 2016.

#### **REFERENCE BOOKS:**

1. Dash, M. C. and Dash, S. P., *Fundamentals of Ecology*, Tata - McGraw Hill, New Delhi, 3<sup>rd</sup> Edition, 2001.
2. Smith, T. M. and Smith, R. L., *Elements of Ecology*, Pearson Education Ltd., England, 9<sup>th</sup> Edition, 2015.
3. Hughes, W., *Essentials of Environmental Toxicology*, Taylor & Francis Press, USA, 2005.
4. Wathern, P., and Hynman, U., *Impact Assessment and Sustainable Resource Management-Theory and Practice*, Routledge Press, 2014.
5. Westman, W. E., *Ecology, Impact Assessment and Environmental Planning*, John Wiley, New York, 1985.

**ADDITIONAL LEARNING RESOURCES:**

1. Rajgopalan, R., *Environment and Ecology - A Complete Guide*, OakBridge Publishing, 2<sup>nd</sup> Edition, 2019.
2. Charles J. Krebs, *Ecology: The Experimental Analysis of Distribution and Abundance*, Pearson Education India, 6<sup>th</sup> Edition, 2008.
3. Mani, M., Ganesh, L.S. and Varghese, K., *Sustainability and Human Settlements*, Sage Publications, New Delhi, 1<sup>st</sup> Edition, 2005.

### III B.Tech. - I Semester

#### (19BT50111) WASTE TO ENERGY

Int. Marks	Ext. Marks	Total Marks	L	T	P	C
40	60	100	3	-	-	3

**PRE-REQUISITES:** Course on Environmental Science.

**COURSE DESCRIPTION:** Waste to energy concept; Municipal solid waste; Thermochemical waste to energy technologies; Biological waste to energy technologies; Waste to energy plants and the environment.

**COURSE OUTCOMES:** On successful completion of this course, the students will able to:

- CO1 Analyze waste to energy process to solve waste management challenges using appropriate tools and techniques, following relevant codes, regulations and latest developments considering society, environment, sustainability and economics besides communicating effectively in graphical form.
- CO2 Analyze municipal solid waste characteristics and sampling techniques to solve solid waste management challenges using appropriate tools and techniques, following relevant codes, regulations and latest developments considering society, environment, sustainability and economics besides communicating effectively in graphical form.
- CO3 Analyze thermochemical waste to energy technologies to solve solid waste management challenges using appropriate tools and techniques, following relevant codes, regulations and latest developments considering society, environment, sustainability and economics besides communicating effectively in graphical form.
- CO4 Analyze traditional and advanced biological technologies for converting waste to energy using appropriate tools and techniques, following relevant codes, regulations and latest developments considering society, environment, sustainability and economics besides communicating effectively in graphical form.
- CO5 Analyze energy plants and the environment to solve waste to energy challenges using appropriate tools and techniques, following relevant codes, regulations and latest developments considering society, environment, sustainability and economics besides communicating effectively in graphical form.

#### **DETAILED SYLLABUS:**

##### **UNIT - I: WASTE TO ENERGY CONCEPT (09 Periods)**

Waste to energy- A historical prospective, Waste as a renewable resource, Global production of power from waste; The politics of waste - Waste management hierarchy, Circular economy/zero Waste, Energy from waste with the circular economy concept.

##### **UNIT - II: MUNICIPAL SOLID WASTE (08 Periods)**

Sources and types of solid waste, Quantity, Factors affecting generation of solid waste, Characteristics, Waste classification, Methods of sampling and characterization, Energy content of the waste.

##### **UNIT - III: THERMOCHEMICAL WASTE TO ENERGY TECHNOLOGIES (10 Periods)**

Traditional waste combustion technologies - Waste processing and treatment facility, Rotary combustors, Fluidized bed combustors; Energy production from waste through advanced thermochemical techniques - Incineration, Gasification and Pyrolysis.

**UNIT - IV: BIOLOGICAL WASTE TO ENERGY TECHNOLOGIES (10 Periods)**

Energy production from waste through biological techniques - Anaerobic digestion, Fermentation, Transesterification, Advanced microbial fuel cells; Cultivation of algal biomass from wastewater and energy production from algae.

**UNIT - V: WASTE TO ENERGY PLANTS AND THE ENVIRONMENT (08 periods)**

Emission limits for waste combustion, Environmental politics and science, Waste to energy plant cost, Latest developments in waste to energy, Case Studies.

**Total Periods: 45**

***Topics for self-study are provided in the lesson plan.***

**TEXT BOOKS:**

1. Breeze, Paul, *Energy from Waste*, Academic Press, 1<sup>st</sup> Edition, 2017.
2. Singh, R. P., Prasad, V. and Vaish, B., *Advances in Waste-to-Energy Technologies*, CRC Press, 1<sup>st</sup> Edition, 2019.

**REFERENCE BOOKS:**

1. Maczulak, A. E., *Environmental Engineering: Designing a Sustainable Future*, Infobase Publishing, 4<sup>th</sup> Edition, 2010.
2. Kalogirou, E. N., *Waste-to-Energy Technologies and Global Applications*, CRC Press, 1<sup>st</sup> Edition, 2017.
3. Klinghoffer, N. B., & Castaldi, M. J., *Waste to Energy Conversion Technology*, Elsevier, 3<sup>rd</sup> Edition, 2013.

**ADDITIONAL LEARNING RESOURCES:**

1. Rogoff, M. J., & Screve, F., *Waste-to-energy: Technologies and Project Implementation*, Academic Press, 1<sup>st</sup> Edition, 2019.
2. Trabold, T., and Babbitt, C. W., *Sustainable Food Waste-to-Energy Systems*, Academic Press, 1<sup>st</sup> Edition, 2018.

### III B.Tech. - II Semester

#### (19BT60126) ENVIRONMENTAL SUSTAINABILITY

Int. Marks	Ext. Marks	Total	L	T	P	C
40	60	100	3	-	-	3

**PREREQUISITES:** Course on Environmental Science, Sustainable Engineering

**COURSE DESCRIPTION:** Environmental measurements from different disciplines and sustainability concepts; Environmental chemistry and physical process in environment; Environmental risk assessments with concepts of EIA and LCA; Sustainability assessment of water and wastewater treatment; Sustainability assessment of solid waste management and air pollution issues.

**COURSE OUTCOMES:** On successful completion of this course, the students will be able to:

- CO1 Analyze environmental measurements and sustainability concepts to solve environmental sustainability challenges using appropriate tools and techniques, following relevant codes, regulations and latest developments considering society, environment, sustainability and economics besides communicating effectively in graphical form.
- CO2 Analyze environmental chemistry and physical processes to solve environmental sustainability challenges using appropriate tools and techniques, following relevant codes, regulations and latest developments considering society, environment, sustainability and economics besides communicating effectively in graphical form.
- CO3 Analyze environmental risk assessment with concepts of EIA and LCA to solve environmental sustainability problems using appropriate tools and techniques following relevant codes and latest developments considering society, environment, sustainability and economics besides communicating effectively in graphical form.
- CO4 Analyze water and wastewater treatment to solve environmental sustainability problems using appropriate tools and techniques, following relevant codes, regulations and latest developments considering health, society, environment, sustainability and economics besides communicating effectively in graphical form.
- CO5 Analyze sustainable assessment of solid waste management and air pollution issue to solve complex problems using appropriate tools and techniques, following relevant codes, regulations and latest developments considering health, society, environment, sustainability and economics besides communicating effectively in graphical form.

#### **DETAILED SYLLABUS:**

##### **UNIT – I: ENVIRONMENTAL MEASUREMENTS FROM DIFFERENT DISCIPLINES AND SUSTAINABILITY CONCEPTS (09 Periods)**

Environmental measurements - Mass concentration units, Partial pressure units, Other types of units, Qualitative and quantitative measurements; Sustainability concepts and evolution, Engineering for sustainability.

##### **UNIT – II: ENVIRONMENTAL CHEMISTRY AND PHYSICAL PROCESS IN ENVIRONMENT (09 Periods)**

Environmental chemistry, Mass balance and reactor systems; Mass balance in continuous reactor, continuous stirred tank reactor (CSTR) and Plug flow reactor; Plug flow reactor and energy flow, Energy balance and earth overshoot day, Mass transport processes.

**UNIT – III: ENVIRONMENTAL RISK ASSESSMENT WITH CONCEPTS OF EIA AND LCA (09 Periods)**

Life Cycle Assessment (LCA); Environmental Impact Assessment (EIA) - Fundamentals, Evolution of EIA (Global and Indian Scenario), Elements of EIA- Screening, Scoping, Public consultation, Environmental clearance process in India - Key elements in 2006 EIA (Govt. of India) notification; Environmental risk, Environmental impact calculation by using LCA technique, Risk assessments with concepts of EIA and LCA, Case studies.

**UNIT – IV: SUSTAINABILITY ASSESSMENT OF WATER AND WASTEWATER TREATMENT (08 Periods)**

Sustainability assessment in Water purification – Processes, Engineered systems – Aeration, Solids separation, Settling operations, Coagulation, Softening, Filtration, Disinfection; Sustainability assessment in wastewater treatment process and disposal – Primary, Secondary and Tertiary.

**UNIT – V: SUSTAINABILITY ASSESSMENT OF SOLID WASTE MANAGEMENT AND AIR POLLUTION ISSUES (10 Periods)**

Sustainability assessment of solid waste management –Need and scope; Municipal solid waste – Types, Composition and characteristics; Methods of collection and transportation; Methods of disposal – Open dumping, Sanitary landfill, Composting and Incineration; Utilization - 6R Concept; Sustainability assessment of air pollution issues – Need and scope, Classification, Sources – Line, Area, Stationary, Mobile; Effects of air pollutants on man, Material and vegetation; Global effects of air pollution.

**Total Periods: 45**

**Topics for self-study are included in the lesson plan.**

**TEXT BOOKS:**

1. Davis, M. L. and Cornwell, D. A., *Introduction to Environmental Engineering*, McGraw-Hill, 5<sup>th</sup> Edition, 2008.
2. Keong, Choy Yee, *Global Environmental Sustainability: Case Studies and Analysis of the United Nations' Journey toward Sustainable Development*, Elsevier, 2020.

**REFERENCE BOOKS:**

1. Singh, Ritu, and Sanjeev Kumar, *Green Technologies and Environmental Sustainability*, Springer, 2<sup>nd</sup> Edition, 2017.
2. Joumard, Robert, and Henrik Gudmundsson, *Indicators of Environmental Sustainability in Transport: An Interdisciplinary Approach to Methods*, European Commission, 2<sup>nd</sup> Edition, 2010.
3. Smith, Fraser, *Environmental Sustainability: Practical Global Applications*, CRC Press, 1<sup>st</sup> Edition, 2020.

**ADDITIONAL LEARNING RESOURCES:**

1. Burke, G., Singh, B. R. and Theodore, L., *Handbook of Environmental Management and Technology*, John Wiley & Sons, 2<sup>nd</sup> Edition, 2000.
2. Peavy, Howard S., Donald R. Rowe, and George Tchobanoglous, *Environmental Engineering*, McGraw-Hill, Indian Edition, 1<sup>st</sup> Edition, 2017.

### III B.Tech. - II Semester

#### (19BT60127) SUSTAINABLE ENERGY SYSTEMS

Int. Marks	Ext. Marks	Total Marks	L	T	P	C
40	60	100	3	-	-	3

**PREREQUISITES:** Courses on Environmental Science, Sustainable Engineering

**COURSE DESCRIPTION:** The energy landscape and sustainability; Solar and wind energy; Biomass, geothermal, tidal and wave energies; Electricity storage technologies; Grid integration of renewable energy.

**COURSE OUTCOMES:** On successful completion of this course, the students will be able to:

- CO1 Analyze the energy landscape and sustainability to provide solutions to energy problems using appropriate tools and techniques following relevant standards considering society, health and environment besides communicating effectively in graphical form.
- CO2 Analyze solar and wind energy systems to solve the complex energy problems using appropriate tools and techniques following relevant standards considering society, health, environment, sustainability and economics besides communicating effectively in graphical form.
- CO3 Analyze biomass, geothermal, tidal and wave energy systems to solve the complex energy problems using appropriate tools and techniques following relevant standards considering society, health, environment, sustainability and economics besides communicating effectively in graphical form.
- CO4 Analyze electric storage technology systems to solve the complex energy problems using appropriate tools and techniques following relevant standards and latest developments considering society, health, environment, sustainability and economics besides communicating effectively in graphical form.
- CO5 Analyze grid integration of renewable energy to solve the complex energy problems using appropriate tools and techniques following relevant standards considering society, health, environment, sustainability and economics besides communicating effectively in graphical form.

#### **DETAILED SYLLABUS:**

##### **UNIT - I: THE ENERGY LANDSCAPE AND SUSTAINABILITY (09 Periods)**

Current global energy use, National and international energy consumption and related greenhouse gas emissions, Lifetime of fossil fuels, Sustainability and energy use, Energy conversion technologies, Energy forms and conversion, First and second laws of thermodynamics and efficiencies; Devices - Heat engines, Refrigerators, Heat pumps; Instantaneous and average power.

##### **UNIT - II: SOLAR AND WIND ENERGY (09 Periods)**

Principles of solar radiation, Resource foundations, Technology challenges, Sustainability, Solar energy industry and economics, Net Metering; Origin of the wind, Power in the wind, Wind resource basics, Wind energy technologies, Challenges, Sustainability, Wind energy Industry.

##### **UNIT - III: BIOMASS, GEOTHERMAL, TIDAL AND WAVE ENERGIES (09 Periods)**

Sources of feedstocks; Biofuels - Bioethanol, Biodiesel, Algal, Jatropha and Biogas; Conversion technology, Diesel and ethanol, Biogas, Electricity production, Transportation, Challenges, Sustainability, Economics; Geothermal energy - Principles, Geothermal potential and technology, Electricity production, Conversion technology,



Challenges, Economics; Tidal and wave energies, Conversion technologies, Sustainability.

**UNIT - IV: ELECTRICITY STORAGE TECHNOLOGIES (09 Periods)**

Introduction, Battery energy storage technologies - Lithium-ion batteries, Full cells, Nickel-based batteries, Lead-acid batteries, Sodium-sulfur batteries; Hydro energy storage - Applications of pump hydro energy storage plant, Site selection for pump hydro energy storage plant; Thermal energy storage, Capacitors and applications, Latest developments.

**UNIT - V: GRID INTEGRATION OF RENEWABLE ENERGY (09 Periods)**

Variability, Intermittency and dispatchability, Electric grid infrastructure, Integrating renewable energy into the grid, Growing a more efficient grid, The smart grid, Secure communication in the smart grid; Cogeneration plant and power distribution in industry, Micro grids.

**Total Periods: 45**

**Topics for self-study are provided in the lesson plan.**

**TEXT BOOKS:**

1. Boyle, Godfrey, *Renewable Energy: Power for a Sustainable Future*, Oxford University Press, 3<sup>rd</sup> Edition, 2012.
2. Jefferson W. Tester, Elisabeth M. Drake, Michael J. Driscoll, Michael W. Golay, William A. Peters, *Sustainable Energy (Choosing Among Options)*, MIT Press, 2<sup>nd</sup> Edition, 2012.

**REFERENCE BOOKS:**

1. Gilbert M. Masters, *Renewable and Efficient Electric Power Systems*, John Wiley & Sons, Inc., Hoboken, New Jersey, 2<sup>nd</sup> Edition, 2013.
2. Vanek, F.M., Albright, L.D., *Energy Systems Engineering - Evaluation and Implementation*, McGraw-Hill, 2<sup>nd</sup> Edition, 2008.
3. David MacKay, *Sustainable Energy: Without the Hot Air*, UIT Cambridge Ltd., Cambridge, England, 2009.
4. Frank Kreith, *Principles of Sustainable Energy Systems*, , CRC Press, Taylor and Francis group, 2<sup>nd</sup> Edition, 2014.

**ADDITIONAL LEARNING RESOURCES:**

1. Richter Burton, *Beyond Smoke and Mirrors: Climate Change and Energy in the 21<sup>st</sup> Century*, Cambridge University Press, New York, 2010.

### III B.Tech. - II Semester

#### (19BT60128) SUSTAINABILITY IN THE BUILT ENVIRONMENT

Int. Marks	Ext. Marks	Total Marks	L	T	P	C
40	60	100	3	-	-	3

**PRE-REQUISITES:** Courses on Environmental Science, Sustainable Engineering.

**COURSE DESCRIPTION:** Sustainable urban development; Sustainable site planning and analysis; Sustainable buildings; Building envelope and services; Management of sustainable built environment.

**COURSE OUTCOMES:** On successful completion of this course, the students will be able to:

- CO1 Analyze sustainable urban development to solve problems associated with the built environment using appropriate tools and techniques following relevant standards considering society, health and environment besides communicating effectively in graphical form.
- CO2 Analyze sustainable site planning to solve complex problems associated with the built environment using appropriate tools and techniques following relevant standards considering society, health and environment besides communicating effectively in graphical form.
- CO3 Analyze sustainable buildings to solve complex problems associated with the built environment using appropriate tools and techniques following relevant standards considering society, health and environment besides communicating effectively in graphical form.
- CO4 Analyze building envelope and services to solve complex problems associated with the built environment using appropriate tools and techniques following relevant standards considering society, health and environment besides communicating effectively in graphical form.
- CO5 Analyze management of sustainable built environment to solve complex problems using appropriate tools and techniques following relevant standards considering society, health and environment besides communicating effectively in graphical form.

#### DETAILED SYLLABUS:

##### UNIT-I: SUSTAINABLE URBAN DEVELOPMENT (09 Periods)

Urban development - Human activities and their effects; Carbon cycle; Role of construction material such as concrete and steel; CO<sub>2</sub> contribution from cement and other construction materials; GHG emissions - Global climate change; Efforts in sustainable development and construction - Universal efforts, International organizations involved.

##### UNIT - II: SUSTAINABLE SITE PLANNING AND ANALYSIS (09 Periods)

Sustainable site planning, Principles of site analysis, Improving sustainability of a site - Stormwater, Reducing site disturbance, Vegetation; Site analysis - Examples of site analysis; Introduction to alternative energy - Solar, Wind, Hydro, Biofuel etc.

##### UNIT - III: SUSTAINABLE BUILDINGS (09 Periods)

Introduction to sustainable buildings and standards, Green buildings, Energy efficiency and sustainability; Passive House; Net Zero Energy Buildings (NZEB), Examples of different types of NZEB.

**UNIT - IV: BUILDING ENVELOPE AND SERVICES (09 Periods)**

Building envelope effect and energy efficiency measures, Renewable energy integration, Sustainable building services, Sustainable construction and materials, Integrated design, Energy use and CO<sub>2</sub>, Built environment - Aging and susceptibility to natural disasters.

**UNIT – V: MANAGEMENT OF SUSTAINABLE BUILT ENVIRONMENT (09 Periods)**

Life cycle planning, Measuring sustainability; Facilities management - Waste management, Improved amenities, Improved transport infrastructure, Social mix, Accessibility issues, Cultural and historical issues.

**TEXT BOOKS:**

1. Alison Cotgrave and Mike Riley, *Total Sustainability in the Built Environment*, Macmillan Education, 1<sup>st</sup> Edition, 2012.
2. Kevin Lynch and Gary Hack, *Site Planning*, MIT Press, 3<sup>rd</sup> Edition, 1984.

**REFERENCE BOOKS:**

1. William McLean and Pete Silver, *Environmental Design Source Book: Innovative Ideas for a Sustainable Built Environment*, RIBA Publishing, 1<sup>st</sup> Edition, 2021.
2. Tim Dixon, John Connaughton, Stuart Green, *Sustainable Futures in the Built Environment to 2050: A Foresight Approach to Construction and Development*, John Wiley & Sons Ltd., 2018.
3. Rob Fleming, Saglinda H Roberts, *Sustainable Design for the Built Environment*, Routledge Press, London, 1<sup>st</sup> Edition, 2019.
4. Charles J. Kibert, *Sustainable Construction: Green Building Design and Delivery*, Wiley, 4<sup>th</sup> Edition, 2021.

**ADDITIONAL LEARNING RESOURCES:**

1. Mani, M., Ganesh, L.S. and Varghese, K., *Sustainability and Human Settlements*, Sage Publications, 1<sup>st</sup> Edition, 2005.
2. Barton, H., Grant, M., Guise, R., *Shaping Neighbourhoods: For Local Health and Global Sustainability*, Routledge Press, 2<sup>nd</sup> Edition, 2020.
3. <https://nptel.ac.in/courses/105/102/105102195/>
4. <https://nptel.ac.in/courses/124/107/124107011/>

## IV B.Tech. - I Semester

### (19BT70117) ENVIRONMENTAL ECONOMICS

Int. Marks	Ext. Marks	Total	L	T	P	C
40	60	100	3	-	-	3

**PREREQUISITES:** Courses on Environmental Science, Sustainable Engineering.

**COURSE DESCRIPTION:** Fundamentals of environmental economics; Economy and the natural environment interaction; Economic development and environment; Valuation of environmental goods and services; Sustainable economic development.

**COURSE OUTCOMES:** On successful completion of this course, the students will able to:

- CO1 Analyze fundamentals of environmental economics to solve environmental economics challenges associated with sustainable design of technology systems considering latest developments, society, environment, economic, and sustainability besides communicating effectively in graphical form.
- CO2 Analyze economy and the natural environment interaction to solve ecological limits and scarcity of eco-services approaches using different tools and techniques considering latest developments, relevant guidelines, environment and sustainability besides communicating effectively in graphical form.
- CO3 Analyze economic development and environment to solve environmental cost-benefit challenges using different tools and techniques considering latest developments, relevant guidelines, environment and sustainability besides communicating effectively in graphical form.
- CO4 Analyze valuation of environmental goods and services to solve methodical challenges using different tools and techniques considering latest developments, relevant guidelines, environment and sustainability besides communicating effectively in graphical form.
- CO5 Analyze sustainable economic development to solve environmental economics challenges using different tools and techniques considering latest developments, relevant guidelines, environment and sustainability besides communicating effectively in graphical form.

#### **DETAILED SYLLABUS:**

#### **UNIT – I: FUNDAMENTALS OF ENVIRONMENTAL ECONOMICS (10 Periods)**

Fundamentals of environmental economics, Review of microeconomics and welfare economics, Ecology-economy interaction, Perspective of economic modeling- the concept and conditions of sustainability of the human economy, Classification and characterization of resources and pollution as a public good or bad, Role of Externalities as the fundamental determinants, Property Rights, Market, Spatial-temporal dimensions of externality- command and control, Market approaches, Green tax, Taxes in controlling externalities

#### **UNIT - II: ECONOMY AND THE NATURAL ENVIRONMENT INTERACTION**

**(08 Periods)**

An overview of the economy and the natural environment; Interaction using an input-output based general equilibrium approach to show how ecological limits and scarcity of eco-services would affect the resource allocation and prices; Regimes of natural resources, Types of goods, Provision of public goods.

**UNIT – III: ECONOMIC DEVELOPMENT AND ENVIRONMENT (09 Periods)**

The relation between development environmental Quality - Environmental Kuznets curve; Development vs conservation of environmental resources - Ecosystem flips and irreversibility - Krutilla-Fisher equation; Environmental cost-benefit analysis under strong and weak conditions of sustainability; Choice of time discount rate for evaluation - Sustainability premium.

**UNIT – IV: VALUATION OF ENVIRONMENTAL GOODS AND SERVICES (10 Periods)**

Theory of environmental valuation and conceptual basis of its methods - Compensating variations and surplus, Equivalent variations and surplus, Willingness to pay or accept for improvement or loss of environmental goods and services; Empirical approaches in environmental valuation; Indirect methods of environmental valuation, Non-demand function methods of valuation, Revealed preference methods - (a) Hedonic Pricing, (b) Household production function approach, Defensive cost, Health cost and travel cost methods; The direct method of environmental valuation - Stated preference - Contingent valuation method.

**UNIT – V: SUSTAINABLE ECONOMIC DEVELOPMENT (08 Periods)**

Capital theoretic basis of the notion of sustainable development - Sustainable Development as non-declining intertemporal utility or that of the value of the wealth. Concepts of Genuine investment or savings, Green National Income, Natural capital stock and sustainable resource accounting, Strong and weak sustainability, Environmental adjustment of national income.

**Total Periods: 45**

**Topics for self-study are included in the lesson plan.**

**TEXT BOOKS:**

1. Siebert, H. and Siebert, H., *Economics of the Environment*. Massachusetts: Lexington Books, 9<sup>th</sup> Edition, 1981.
2. Pearce, David W., and Kerry Turner R., *Economics of Natural Resources and The Environment*, JHU Press, Revised and Enlarged Edition, 1990.

**REFERENCE BOOKS:**

1. Nick Hanley, Jason F Shorgen and Ben White, *Environmental Economics Theory and Practice*, MacMillan, 2<sup>nd</sup> Edition, 2006.
2. Tietenberg, Tom and Lynne Lewis, *Environmental and Natural Resource Economics*, Routledge, 11<sup>th</sup> Edition, 2018.
3. Kumar, P., *The Economics of Ecosystems and Biodiversity: Ecological and Economic Foundations*, Routledge, 2012.

**ADDITIONAL LEARNING RESOURCES:**

1. Field, C., *Environmental Economics: An Introduction*, McGraw-Hill Book Company (UK) Ltd, 8<sup>th</sup> Edition, 2021.
2. Sengupta, R., *Ecological Limits and Economic Development*, OUP Catalogue, 2013.

## IV B.Tech. - I Semester

### (19BT70118) SUSTAINABLE CITIES

Int. Marks	Ext. Marks	Total Marks	L	T	P	C
40	60	100	3	-	-	3

**PRE-REQUISITES:** Courses on Environmental Science, Sustainable Engineering.

**COURSE DESCRIPTION:** Sustainability and urban development; Functions of cities; Inclusive, Safe and productive cities; Sustainable urban services and infrastructure; Governing sustainable cities.

**COURSE OUTCOMES:** On successful completion of this course, the students will able to:

- CO1 Analyze sustainability and urban development to solve problems associated with cities using appropriate tools and techniques following relevant codes, regulations and latest developments considering society, environment, sustainability and economics besides communicating effectively in graphical form.
- CO2 Analyze city functioning for sustainability to solve problems associated with cities using appropriate tools and techniques, following relevant codes, regulations and latest developments considering society, environment, sustainability and economics besides communicating effectively in graphical form.
- CO3 Analyze inclusiveness, safety and productivity in cities to solve problems associated with cities using appropriate tools and techniques, following relevant codes, regulations and latest developments considering society, environment, sustainability and economics besides communicating effectively in graphical form.
- CO4 Analyze sustainable urban services and infrastructure to solve problems associated with cities using appropriate tools and techniques, following relevant codes, regulations and latest developments considering society, environment, sustainability and economics besides communicating effectively in graphical form.
- CO5 Analyze governance for sustainable cities to solve problems associated with cities using different tools and techniques considering latest developments, relevant guidelines, environment and sustainability besides communicating effectively in graphical form.

#### DETAILED SYLLABUS:

#### UNIT - I: SUSTAINABILITY AND URBAN DEVELOPMENT (08 Periods)

The urban opportunity; Cities - Cultural and social transformation; Challenge of urban politics, Planning and governance, Urban research methods, Urban theory and history, Urban development and the environment, Urban growth and the environment - Why cities grow?, Externalities and the environment, Urban economic restructuring, City size and settlement planning.

#### UNIT - II: FUNCTIONS OF CITIES (09 Periods)

Understanding urban systems, Municipal, Regional and national governance, Urban utilities, Urban public finance and taxation; Law, order and conflict; Land management and planning, Lessons from London and Mumbai.

#### UNIT - III: INCLUSIVE, SAFE AND PRODUCTIVE CITIES (10 Periods)

What is urban poverty?, Measuring urban poverty, Poverty reduction in cities, Affordable and adequate housing, Who can deliver the housing we need?, Safety and violence, Urban vulnerabilities; Making cities productive and reduce inequality- City production and consumption, Women in the informal economy, Migration, mobility and the urban-rural continuum Wealth and inequality, Case: SEWA, India, Migration and the refugee crisis; Improving human development in cities – Addressing the challenges of urban public health, Solutions for improving urban health, Education and skills, Higher

education in cities, Gender in the city, Human rights and justice, Law and equality, Apartheid in South African cities.

**UNIT - IV: SUSTAINABLE URBAN SERVICES AND INFRASTRUCTURE (08 Periods)**

Sustainable environmental services and infrastructure, Sustainable transport planning, ICT, Sustainable urban energy systems, Sustainable transport: Bangkok; How can cities be resilient -Air, water, food and natural resources; City risk exposure; Climate impacts, adaptation and mitigation; Building urban resilience, Environmental planning and the politics of change.

**UNIT - V: GOVERNING SUSTAINABLE CITIES (10 periods)**

Sustainable environmental practices, Urban disaster risk management, Post-disaster recovery, SDGs and other global processes, New institutions and governance, Public participation and democracy, Financing sustainable development, Measuring and monitoring the SDGs, Opportunities of secondary cities.

**Total Periods: 45**

**Topics for self-study are included in the lesson plan.**

**TEXT BOOKS:**

1. Al-Zu'bi, Maha, and Vesela Radovic, *SDG11-Sustainable Cities and Communities: Towards Inclusive, Safe, and Resilient Settlements*, Emerald Group Publishing, 1<sup>st</sup> Edition, 2019.
2. Rydin, Yvonne, *Governing for Sustainable Urban Development*, Earthscan, 2012.
3. Evans, Bob, Marko Joas, Susan Sundback, and Kate Theobald, *Governing Sustainable Cities*, Routledge, 2013.

**REFERENCE BOOKS:**

1. Register, R., *EcoCities: Rebuilding Cities in Balance with Nature*, New Society Publishers, Revised Edition, 2006.
2. Yigitcanlar, T, *Sustainable Urban and Regional Infrastructure Development: Technologies, Applications and Management: Technologies, Applications and Management*, IGI Global, 2007.

**ADDITIONAL LEARNING RESOURCES:**

1. Flint J. and Raco M., *The Future of Sustainable Cities: Critical Reflections*, Policy Press, 2<sup>nd</sup> Edition, 2012.
2. Corburn, J., *Toward the Healthy City: People, Places and the Politics of Urban Planning*, MIT Press, 3<sup>rd</sup> Edition, 2009.

## IV B.Tech. - I Semester

### (19BT70119) SUSTAINABLE DESIGN OF TECHNOLOGY SYSTEMS

Int. Marks	Ext. Marks	Total Marks	L	T	P	C
40	60	100	3	--	--	3

**PRE-REQUISITES:** Courses on Environmental Science, Sustainable Engineering.

**COURSE DESCRIPTION:** Sustainability and sustainable development; Product life cycle design – Methods and strategies; Product life cycle design – Software tools; Designing for sustainable product-service system – Methods and tools; Design for sustainability – Engineering design criteria and guidelines.

**COURSE OUTCOMES:** On successful completion of this course, the students will be able to:

- CO1 Analyze sustainability and sustainable development to solve complex problems associated with sustainable design of technology systems using appropriate tools and techniques, following relevant codes, regulations and latest developments considering society, environment and economics besides communicating effectively in graphical form.
- CO2 Analyze product life cycle design methods and strategies to solve complex problems associated with sustainable design of technology systems using appropriate tools and techniques, following relevant codes, regulations and latest developments considering society, environment and economics besides communicating effectively in graphical form.
- CO3 Analyze product life cycle design software tools to solve complex problems associated with sustainable design of technology systems using appropriate tools and techniques, following relevant codes, regulations and latest developments considering society, environment and economics besides communicating effectively in graphical form.
- CO4 Design sustainable product-service systems to solve complex problems associated with sustainable design of technology systems using appropriate tools and techniques, following relevant codes, regulations and latest developments considering society, environment and economics besides communicating effectively in graphical form.
- CO5 Design engineering criteria and guidelines to solve complex problems associated with sustainable design of technology systems using appropriate tools and techniques, following relevant codes, regulations and latest developments considering society, environment and economics besides communicating effectively in graphical form.

#### DETAILED SYLLABUS:

#### UNIT - I: SUSTAINABILITY AND SUSTAINABLE DEVELOPMENT (09 Periods)

Sustainability and sustainable development - Understanding un-sustainability and need for Sustainability, Definitions, Pathway, Systems approach to design; Evolution of sustainability within design - Diverse approaches to design for sustainability, Relationship between approaches to design for sustainability and the application context.

#### UNIT - II: PRODUCT LIFE CYCLE DESIGN – METHODS AND STRATEGIES

(08 Periods)

Life Cycle Assessment (LCA) - Product Life Cycle Assessment, LCA introduction, LCA methodology, LCA goal, LCA scope, Inventory analysis, Impact assessment, Interpretation; Environmental risk, Environmental impacts calculation by using LCA technique, Risk assessment with concepts of LCA.



**UNIT - III: PRODUCT LIFE CYCLE DESIGN – SOFTWARE TOOLS (08 Periods)**

History of product design by LCA with examples; ISO 14000, Life cycle analysis, SIMA PRO, LCA software and other software for LCA, LCA methodical challenges - Allocation and uncertainty, Sensitivity analysis.

**UNIT - IV: DESIGNING FOR SUSTAINABLE PRODUCT-SERVICE SYSTEM – METHODS AND TOOLS (10 Periods)**

Sustainable product service system design – Definition, Types and examples; Sustainable product service system – Transition path and challenges, Sufficiency economy philosophy applied to sustainable product-service system (PSS) thinking, Khadi movement as a precursor to PSS thinking.

**UNIT - V: DESIGN FOR SUSTAINABILITY – ENGINEERING DESIGN CRITERIA AND GUIDELINES (09 periods)**

Sustainable product-service system design applied to distributed economy, Other design for sustainability tools and approaches – Agriculture, Cities and communities, Carbon footprint, Green buildings, Green materials, Green energy, Sustainable development, Zero waste, Circular economy.

**Total Periods: 45**

**Topics for self-study are provided in the lesson plan.**

**TEXT BOOKS:**

1. Horne, Ralph, Tim Grant, and Karli Verghese, *Life Cycle Assessment: Principles, Practice and Prospects*, Csiro Publishing, 2009.
2. Bhamra, Tracy, and Vicky Lofthouse, *Design For Sustainability: A Practical Approach*. Routledge, 1<sup>st</sup> Edition, 2016.

**REFERENCE BOOKS:**

1. Vezzoli, C., Kohtala, C., Srinivasan, A., Diehl, J. C, Fusakul, S. M., Xin, L. and Sateesh, D., *Product-service System Design for Sustainability*, Routledge, 1<sup>st</sup> Edition, 2017.
2. Curran, Mary Ann, *Life Cycle Assessment Student Handbook*, John Wiley & Sons, 1<sup>st</sup> Edition, 2015.
3. Hauschild, Michael Z., Ralph K. Rosenbaum and Stig Irvin Olsen, *Life Cycle Assessment*, Springer International Publishing, 2018.
4. Hendrickson, Chris T., Lester B. Lave, and H. Scott Matthews, *Environmental Life Cycle Assessment of Goods and Services: An Input-Output Approach*. Routledge, 2010.

**ADDITIONAL LEARNING RESOURCES:**

1. Sharmistha Banerjee, *System Design for Sustainability*, IIT Guwahati, <https://nptel.ac.in/courses/107/103/107103081/>.
2. Curran, Mary Ann, *Life Cycle Assessment Handbook: A Guide for Environmentally Sustainable Products*, John Wiley & Sons, 3<sup>rd</sup> Edition, 2012.

# **MINOR DEGREE**

**(SVEC-19 Regulations)**

**MINOR DEGREE IN**  
**ARTIFICIAL INTELLIGENCE AND MACHINE LEARNING**

**Offering Department:** Computer Science and Engineering

**Students of Eligible Branches:** ECE, EEE, EIE, ME and CE

**COURSE STRUCTURE**

Year & Semester	Course Code	Course Title	Contact Periods per week				C	Scheme of Examination Max. Marks		
			L	T	P	Total		Int. Marks	Ext. Marks	Total Marks
III B.Tech. I-Sem  (2 Theory + 1 Lab)	19BM50501	Artificial Intelligence	3	-	-	3	3	40	60	100
	19BM50502	Soft Computing	3	-	-	3	3	40	60	100
	19BM50503	Python for Data Science	3	-	-	3	3	40	60	100
	19BM50531	Python for Data Science Lab	-	-	2	2	1	50	50	100
III B.Tech. II-Sem  (2 Theory + 1 Lab)	19BM60501	Data Science	3	-	-	3	3	40	60	100
	19BM60502	Nature Inspired Algorithms	3	-	-	3	3	40	60	100
	19BM60503	Machine Learning	3	-	-	3	3	40	60	100
	19BM60531	Machine Learning Lab	-	-	2	2	1	50	50	100
IV B.Tech. I-Sem  (1 Theory + 1 Lab)	19BM70501	Deep Learning	3	-	-	3	3	40	60	100
	19BM70531	Deep Learning Lab	-	-	2	2	1	50	50	100

**Note:** If any student has chosen a course from the above list in their regular curriculum then, he/she is not eligible to opt the same course/s for the Minor degree. It is the responsibility of the student to acquire/complete prerequisite before taking the respective course.

### III B. Tech. – I Semester

#### (19BM50501) ARTIFICIAL INTELLIGENCE

Int. Marks	Ext. Marks	Total Marks	L	T	P	C
40	60	100	3	-	-	3

#### PRE-REQUISITES: -

**COURSE DESCRIPTION:** Introduction to artificial intelligence, Designing intelligent agents, Solving general purpose problems, Search in complex environments, Probabilistic reasoning, Represent knowledge and reason under uncertainty, Robotics, Ethics and safety in AI.

**COURSE OUTCOMES:** After successful completion of the course, students will be able to:

- CO1. Architect intelligent agents using artificial intelligence techniques and principles.
- CO2. Analyze and interpret the problem, identify suitable solutions using heuristic functions, optimization algorithms and search algorithms.
- CO3. Select and apply appropriate knowledge representation to build Bayesian network models to reason under uncertainty.
- CO4. Investigate robot hardware and frameworks for intelligent robotic perception.
- CO5. Demonstrate knowledge on ethical implications of intelligent machines for providing privacy, trust, security and safety.

#### DETAILED SYLLABUS:

##### UNIT-I: INTRODUCTION TO ARTIFICIAL INTELLIGENCE (10 periods)

Foundations of artificial intelligence, History of artificial intelligence, State of the art, Risks and benefits of AI, Intelligent agents – Agents and environments, The concept of rationality, Structure of agents.

##### UNIT-II: PROBLEM SOLVING BY SEARCHING (9 periods)

Problem solving agents, Search algorithms, Uninformed search strategies, Informed search strategies – Greedy best-first search, A\* search; Heuristic functions.

##### UNIT-III: SEARCH IN COMPLEX ENVIRONMENTS (9 periods)

Local search algorithms and optimization problems – Hill-climbing search, Simulated annealing, Local beam search, Evolutionary algorithms; Optimal decisions in games – The minimax search algorithm, Optimal decisions in multiplayer games, Alpha-Beta pruning, Move ordering; Monte Carlo tree search.

##### UNIT-IV: PROBABILISTIC REASONING (9 periods)

Representing Knowledge in an uncertain domain, Semantics of Bayesian networks, Probabilistic reasoning over time – Time and uncertainty, Inference in temporal models, Hidden Markov models, Kalman Filter.

**UNIT-V: ROBOTICS, ETHICS AND SAFETY IN AI****(8 periods)**

**Robotics:** Robots, Robot hardware, Robotic perception, Alternative robotic frameworks, Application domains.

**Ethics and Safety in AI:** Limits of AI, Ethics of AI – Surveillance, security and privacy, Fairness and bias, Trust and transparency, AI safety.

**Total Periods: 45**

**Topics for self-study are provided in the lesson plan**

**TEXT BOOK:**

1. Stuart Russell, Peter Norvig, *Artificial Intelligence: A Modern Approach*, Prentice Hall, 4<sup>th</sup> Edition, 2020.

**REFERENCE BOOKS:**

1. Stephen Lucci, Danny Kopec, *Artificial Intelligence in the 21<sup>st</sup> Century*, Mercury Learning and Information, 3<sup>rd</sup> Edition, 2018.
2. Rich, Knight, Nair, *Artificial intelligence*, Tata McGraw Hill, 3<sup>rd</sup> Edition, 2009.
3. Deepak Khemani, *A First Course in Artificial Intelligence*, McGraw Hill, 2017.
4. Saroj Kaushik, *Artificial Intelligence*, Cengage Learning, 2011.

**ADDITIONAL RESOURCES:**

- <https://searchenterpriseai.techtarget.com/definition/AI-Artificial-Intelligence>
- <http://aima.cs.berkeley.edu/>
- <https://ai.google/education/>
- <https://www.coursera.org/courses?query=artificial%20intelligence>
- <https://www.edureka.co/blog/artificial-intelligence-with-python/>

### III B. Tech. – I Semester

#### (19BM50502) SOFT COMPUTING

Int. Marks	Ext. Marks	Total Marks	L	T	P	C
40	60	100	3	-	-	3

#### PRE-REQUISITES: -

**COURSE DESCRIPTION:** Soft computing technique concepts, Supervised learning networks, Unsupervised learning networks, Genetic algorithms, Fuzzy logic, Hybrid soft computing techniques and applications.

**COURSE OUTCOMES:** After successful completion of the course, students will be able to:

- CO1. Investigate soft computing techniques for solving computational problems.
- CO2. Design efficient neural architectures to model patterns for a given learning problem.
- CO3. Investigate and solve optimization problems using genetic algorithms.
- CO4. Apply fuzzy logic and reasoning to handle uncertainty in engineering problems.
- CO5. Develop intelligent solutions using hybrid soft computing techniques to solve problems of multidisciplinary domains.

#### DETAILED SYLLABUS:

#### UNIT-I: INTRODUCTION TO SOFT COMPUTING AND SUPERVISED LEARNING NETWORKS (10 periods)

**Introduction to Soft Computing:** Neural networks, Application scope of neural networks, Fuzzy logic, Genetic algorithm, Hybrid systems, Soft computing.

**Artificial Neural Networks:** Fundamentals, Basic Models, Terminologies, Linear Separability, Hebb network.

**Supervised Learning Networks:** Perceptron Networks- Theory, Perceptron learning rule, Architecture, Flowchart for training process, Perceptron training algorithm for single and multiple output classes, Perceptron network testing algorithm; Back-Propagation Network - Theory, Architecture, Flow chart for training process, Training algorithm, Learning factors of back-propagation network, Testing algorithm for back-propagation network.

#### UNIT-II: UNSUPERVISED LEARNING NETWORKS (8 periods)

Fixed weight competitive nets – Maxnet, Mexican Hat Net, Hamming network; Kohonen self-organizing feature maps – Theory, Architecture, Flowchart, Training algorithm; Learning vector quantization – Theory, Architecture, Flowchart, Training algorithm, Variants; Counterpropagation networks – Theory, Full counterpropagation Net, Forward-only counterpropagation Net; Adaptive resonance theory network – Fundamental architecture, Fundamental operating principle, Fundamental algorithm.

#### UNIT-III: GENETIC ALGORITHMS (9 periods)

Genetic algorithms - Biological background, Traditional optimization and search techniques, Genetic algorithm and search space, Genetic algorithms vs. traditional algorithms, Basic terminologies in genetic algorithm, Simple GA, General genetic algorithm, Operators in genetic algorithm, Stopping condition for genetic algorithm flow, Constraints in genetic algorithm, Problem solving using genetic algorithm, Adaptive

genetic algorithms, Hybrid genetic algorithms, Advantages and limitations of genetic algorithm, Applications of genetic algorithm.

#### **UNIT-IV: FUZZY LOGIC**

**(11 periods)**

Introduction to fuzzy logic, Classical sets, Fuzzy sets, Membership function – Features, Fuzzification, Methods of membership value assignments; Fuzzy arithmetic and measures – Fuzzy arithmetic, Extension principle, Fuzzy measures, Measures of fuzziness, Fuzzy integrals; Fuzzy rule base and approximation reasoning - Truth values and tables in fuzzy logic, Fuzzy propositions, Formation of rules, Compound rules, Aggregation of fuzzy rules, Fuzzy reasoning, Fuzzy inference systems, Overview of fuzzy expert system; Fuzzy decision making, Fuzzy logic control systems.

#### **UNIT-V: HYBRID SOFT COMPUTING TECHNIQUES AND APPLICATIONS**

**(7 periods)**

**Hybrid Soft Computing Techniques:** Genetic neuro hybrid systems, Genetic fuzzy hybrid and fuzzy genetic hybrid systems.

**Applications of Soft Computing:** Optimization of traveling salesman problem using genetic algorithm approach, Genetic algorithm-based internet search technique, Soft computing-based hybrid fuzzy controllers, Soft computing-based rocket engine control.

**Total Periods: 45**

**Topics for self-study are provided in the lesson plan**

#### **TEXT BOOK:**

1. S. N. Sivanandam and S. N. Deepa, *Principles of Soft Computing*, Wiley, 3<sup>rd</sup> Edition, 2019.

#### **REFERENCE BOOKS:**

1. S. Rajasekaran and G. A. Vijayalakshmi Pai, *Neural Networks, Fuzzy Logic and Genetic Algorithms: Synthesis and Applications*, PHI Learning Private Ltd, 2011.
2. Udit Chakraborty, Samir Roy, *Soft Computing: Neuro-Fuzzy and Genetic Algorithms*, Pearson, 2013.
3. Saroj Kaushik, Sunita Tewari, *Soft Computing: Fundamentals, Techniques and Applications*, McGraw Hill, 2018.

#### **ADDITIONAL LEARNING RESOURCES:**

- <https://nptel.ac.in/courses/106105173/>

### III B. Tech. – I Semester

#### (19BM50503) PYTHON FOR DATA SCIENCE

Int. Marks	Ext. Marks	Total Marks	L	T	P	C
40	60	100	3	-	-	3

#### PRE-REQUISITES: -

**COURSE DESCRIPTION:** Basics of Data Science, Computation using NumPy, Data exploration using Pandas, Data transformation, Plotting and visualization using Matplotlib, Time series analysis.

**COURSE OUTCOMES:** After successful completion of the course, students will be able to:

- CO1. Demonstrate knowledge on the concepts of data science to perform mathematical computations using efficient storage and data handling methods in NumPy.
- CO2. Apply data preparation and exploration methods using Pandas to perform data manipulation.
- CO3. Create data visualization using charts, plots and histograms to identify trends, patterns and outliers in data using Matplotlib and Seaborn.
- CO4. Develop methods to analyze and interpret time series data to extract meaningful statistics.

#### DETAILED SYLLABUS:

##### UNIT-I: INTRODUCTION

(10 periods)

Basic terminologies of data science, Types of data, Five steps of data science, The NumPy ndarray, Fast element-wise array functions, Array-oriented programming with arrays, File input and output with arrays, Linear algebra, Pseudorandom number generation.

##### UNIT-II: DATA EXPLORATION WITH PANDAS

(10 periods)

Process of exploring data, Pandas data structures – Series, Data frame, Index objects; Essential functionality, Summarizing and computing descriptive statistics, Data loading, storage, and file formats – Reading and writing data in text format, Reading text files in pieces, Writing data to text format; Reading Microsoft Excel files.

##### UNIT-III: DATA CLEANING AND PREPARATION

(8 periods)

Handling missing data – Filtering out missing data, Filling in missing data; Data transformation – Removing duplicates, Transforming data using a function or mapping, Replacing values, Renaming axis indexes, Discretization and binning, Detecting and filtering outliers, Permutation and random sampling, Computing indicator/dummy variables; String manipulation – String object methods, Regular expressions, Vectorized string functions in Pandas.

##### UNIT-IV: DATA VISUALIZATION WITH MATPLOTLIB

(8 periods)

Plotting with Matplotlib – Figures and subplots, Colors, markers and line styles, Ticks, labels and legends, Annotations and drawing on a subplot, Saving plots to file; Plotting with Pandas and Seaborn – Line plots, Bar plots, Histograms and density plots, Scatter plots, Facet grids and categorical data.



**UNIT-V: TIME SERIES ANALYSIS****(9 periods)**

Date and time data types and tools, Time series basics, Date ranges, frequencies, and shifting, Time zone handling, Periods and period arithmetic, Resampling and frequency conversion, Moving window functions.

**Total Periods: 45****Topics for self-study are provided in the lesson plan****TEXT BOOK:**

1. Wes McKinney, *Python for Data Analysis*, O'Reilly, 2<sup>nd</sup> Edition, 2017.

**REFERENCE BOOKS:**

1. Sinan Ozdemir, *Principles of Data Science*, Packt Publishers, 2<sup>nd</sup> Edition, 2018.
2. John Paul Mueller, Luca Massaron, *Python for Data Science for Dummies*, 2<sup>nd</sup> Edition, Wiley, 2015.
3. Rachel Schutt, Cathy O'Neil, *Doing Data Science: Straight Talk from the Frontline*, O'Reilly, 2014.

**ADDITIONAL LEARNING RESOURCES:**

- [https://swayam.gov.in/nd1\\_noc19\\_cs60/preview](https://swayam.gov.in/nd1_noc19_cs60/preview)
- <https://towardsdatascience.com/>
- <https://www.w3schools.com/datascience/>
- <https://github.com/jakevdp/PythonDataScienceHandbook>
- <https://www.kaggle.com>

### III B. Tech. – I Semester

#### (19BM50531) PYTHON FOR DATA SCIENCE LAB

Int. Marks	Ext. Marks	Total Marks	L	T	P	C
50	50	100	-	-	2	1

**PRE-REQUISITES:** A Course on “Python for Data Science”

**COURSE DESCRIPTION:** Hands on practice on the concepts of data science using Python - Computations using NumPy, Data manipulation using Pandas, Data cleaning and preparation, Data visualization using Matplotlib and Seaborn, Time series analysis.

**COURSE OUTCOMES:** After successful completion of the course, students will be able to:

- CO1. Demonstrate efficient storage and data handling methods in NumPy to perform mathematical computations vital for data science.
- CO2. Apply data preparation and data exploration methods using Pandas to perform data manipulation.
- CO3. Create data visualization using charts, plots and histograms to identify trends, patterns and outliers in data importing Matplotlib and Seaborn.
- CO4. Develop methods to analyze and interpret time series data to extract meaningful statistics.
- CO5. Work independently to solve problems with effective communication.

#### LIST OF EXERCISES:

1. Array Computations using NumPy
  - a) Perform arithmetic operations using array.
  - b) Perform slicing and indexing on multi-dimensional arrays.
  - c) Perform computations on multi-dimensional array using universal functions (ufunc).
  - d) Compute arithmetic mean, standard deviation, variance, percentile, minimum and maximum, cumulative sum and product using statistical functions in NumPy.
  - e) Perform set theory operations such as union, intersection, symmetric difference and fetching unique values.
2. Linear Algebra and Random Number generation using linalg and random module in NumPy
  - a) Compute dot product, vector product and inner product of two arrays.
  - b) Perform matrix operations such as multiplication, determinant, sum of diagonal elements and inverse.
  - c) Compute eigenvalues, eigenvectors and singular value decomposition for a square matrix.
  - d) Generate random samples from uniform, normal, binomial, chi-square and Gaussian distributions using numpy.random functions.
  - e) Implement a single random walk with 1000 steps using random module and extract the statistics like minimum and maximum value along the walk's trajectory.

3. Data Manipulation using pandas
  - a) Create DataFrame from List, Dict, List of Dicts, Dicts of Series and perform operations such as column selection, addition, deletion and row selection, addition and deletion.
  - b) Create a DataFrame and perform descriptive statistics functions such as sum, mean, median, mode, standard deviation, skewness, kurtosis, cumulative sum, cumulative product and percent changes.
  - c) Implement the computation of correlation and covariance by considering the DataFrames of stock prices and volumes obtained from Yahoo Finance! Using pandas-datereader package.
4. Working with different data formats using pandas
  - a) Perform reading and writing data in text format using read\_csv and read\_table considering any online dataset in delimited format (CSV).
  - b) Perform reading and writing of Microsoft Excel Files (xlsx) using read\_excel.
5. Data Cleaning and Preparation
  - a) Perform data cleaning by creating a DataFrame and identifying missing data using NA(Not Available) handling methods, filter out missing data using dropna function, fill the missing data using fillna function and remove duplicates using duplicated and drop\_duplicates functions.
  - b) Perform data transformation by modifying set of values using map and replace method and create transformed version of original dataset without modification using rename method.
  - c) Create a DataFrame with normally distributed data using random sampling and detect possible outliers.
6. Perform Data Visualization with Matplotlib and Seaborn considering online dataset for processing.
  - a) Create a Line Plot by setting the title, axis labels, ticks, ticklabels, annotations on subplots and save to a file.
  - b) Create Bar Plots using Series and DataFrame index.
    - i) Create bar plots with a DataFrame to group the values in each row together in a group in bars side by side for each value.
    - ii) Create stacked bar plots from a DataFrame.
  - c) Create Histogram to display the value frequency and Density Plot to generate continuous probability distribution function for observed data.
  - d) Create Scatter Plot and examine the relationship between two one-dimensional data series.
  - e) Create Box plots to visualize data with many categorical variables.
7. Time Series Analysis
  - a) Create time series using datetime object in pandas indexed by timestamps.
  - b) Use pandas.date\_range to generate a DatetimeIndex with an indicated length.
  - c) Perform period arithmetic such as adding and subtracting integers from periods and construct range of periods using period\_range function.
  - d) Convert Series and DataFrame objects indexed by timestamps to

periods with the `to_period` method.

e) Perform resampling, downsampling and upsampling for the time series.

#### **REFERENCE BOOKS:**

1. Wes McKinney, *Python for Data Analysis*, O'Reilly, 2<sup>nd</sup> Edition, 2017.
2. John Paul Mueller, Luca Massaron, *Python for Data Science For Dummies*, 2<sup>nd</sup> Edition, Wiley, 2015.

#### **SOFTWARE/TOOLS:**

- Python 3.8
- Python Libraries – NumPy, Pandas, Matplotlib,
- Anaconda Framework

#### **ADDITIONAL LEARNING RESOURCES:**

- [https://swayam.gov.in/nd1\\_noc19\\_cs60/preview](https://swayam.gov.in/nd1_noc19_cs60/preview)
- <https://towardsdatascience.com/>
- <https://www.w3schools.com/datascience/>
- <https://github.com/jakevdp/PythonDataScienceHandbook>
- <https://www.kaggle.com>

**III B. Tech. – II Semester**  
**(19BM60501) DATA SCIENCE**

Int. Marks	Ext. Marks	Total Marks	L	T	P	C
40	60	100	3	-	-	3

**PRE-REQUISITES: -**

**COURSE DESCRIPTION:** Concepts of data science, Extracting meaning from data, The dimensionality problem, Plotting with pandas and seaborn, Probability distributions, Time series analysis, Predictive modeling.

**COURSE OUTCOMES:**After successful completion of the course, students will be able to:

- CO1. Demonstrate knowledge on the concepts of data science to perform data analysis.
- CO2. Develop methods to extract meaning from data using feature selection techniques.
- CO3. Create data visualization using charts, plots and histograms to identify trends, patterns and outliers in data using Matplotlib and Seaborn.
- CO4. Develop distribution functions to analyze and interpret data to extract meaningful statistics.
- CO5. Design and develop predictive models for a given problem to support prediction and forecasting.

**DETAILED SYLLABUS:**

**UNIT-I: INTRODUCTION (9 periods)**

Definition of data science, Skills for data science, Tools for data science, Data types, Data collections, Data preprocessing, Data analysis and data analytics, Descriptive analysis, Diagnostic analytics, Predictive analytics, Prescriptive analytics, Exploratory analysis, Mechanistic analysis.

**UNIT-II: DATA EXTRACTION (9 periods)**

Extracting meaning from data – Feature selection, User retention, Filters, Wrappers, Entropy, Decision tree algorithm; Random forests, The dimensionality problem, Single value decomposition, Principal component analysis.

**UNIT-III: DATA VISUALIZATION (8 periods)**

A Brief matplotlib API primer, Plotting with Pandas and Seaborn – Line plots, Bar plots, Histograms and density plots, Scatter plots, Facet grids and Categorical data; Other Python visualization tools.

**UNIT-IV: STATISTICAL THINKING (11 periods)**

Distributions – Representing and plotting histograms, Outliers, Summarizing distributions, Variance, Reporting results; Probability mass function – Plotting PMFs, Other visualizations, The class size paradox, Data frame indexing; Cumulative distribution functions - Limits of PMFs, Representing CDFs, Percentile based statistics,

Random numbers, Comparing percentile ranks; Modeling distributions - Exponential distribution, Normal distribution, Lognormal distribution.

**UNIT-V: TIME SERIES ANALYSIS AND PREDICTIVE MODELING (8 periods)**

Time series analysis – Importing and cleaning, Plotting, Moving averages, Missing values, Serial correlation, Autocorrelation; Predictive modeling – Overview, Evaluating predictive models, Building predictive model solutions, Sentiment analysis.

**Total Periods: 45**

**Topics for self-study are provided in the lesson plan**

**TEXT BOOKS:**

1. Chirag Shah, *A Hands-on Introduction to Data Science*, Cambridge University Press, 2020.
2. Alen B. Downey, *Think Stats: Exploratory Data Analysis*, O'Reilly, 2<sup>nd</sup> Edition, 2014.

**REFERENCE BOOKS:**

1. Wes McKinney, *Python for Data Analysis*, O'Reilly, 2<sup>nd</sup> Edition, 2017.
2. Ofer Mendeleevitch, Casey Stella, Douglas Eadline, *Practical Data science with Hadoop and Spark: Designing and Building Effective Analytics at Scale*, Addison Wesley, 2017.
3. Rachel Schutt, Cathy O'Neil, *Doing Data Science: Straight Talk from the Frontline*, O'Reilly, 2014.
4. Jake VanderPlas, *Python Data Science Handbook: Essential Tools for Working with Data*, O'Reilly, 2017.

**ADDITIONAL LEARNING RESOURCES:**

- [https://swayam.gov.in/nd1\\_noc19\\_cs60/preview](https://swayam.gov.in/nd1_noc19_cs60/preview)
- <https://towardsdatascience.com/>
- <https://www.w3schools.com/datascience/>
- <https://github.com/jakevdp/PythonDataScienceHandbook>
- <https://www.kaggle.com>

### III B. Tech. – II Semester

#### (19BM60502) NATURE INSPIRED ALGORITHMS

Int. Marks	Ext. Marks	Total Marks	L	T	P	C
40	60	100	3	-	-	3

**PRE-REQUISITES:** A course on "Differential Equations and Multivariable Calculus".

**COURSE DESCRIPTION:** Optimization, Classical optimization techniques, Nature inspired algorithms, Genetic algorithm, Particle swarm optimization, Ant colony optimization, Bee colony optimization, Cuckoo search algorithm, Firefly algorithm, Bat algorithm, Gray wolf optimization, Elephant herding optimization, Applications of nature inspired algorithms.

**COURSE OUTCOMES:** After successful completion of the course, students will be able to:

- CO1 Demonstrate knowledge on optimization and classical optimization techniques to find optimal solutions for a given problem.
- CO2 Analyze the key components and mathematical aspects of nature inspired algorithms.
- CO3 Design efficient solutions for optimization problems using nature inspired algorithms.
- CO4 Investigate the applications of nature inspired algorithms to solve wide range of optimization problems.

#### **DETAILED SYLLABUS:**

##### **UNIT-I: INTRODUCTION TO OPTIMIZATION (9 periods)**

**Introduction to Optimization:** Fundamentals of optimization, Types of optimization problems, Examples of optimization, Formulation of optimization problems, Classification of optimization algorithms, Traveling salesman problem, Knapsack problem.

**Classical Optimization Techniques:** Mathematical model of optimization, Linear programming – Simplex method, Revised simplex method, Kamarkar's method, Duality theorem, Decomposition principle, Transportation problem; Nonlinear Programming – Quadratic programming, Geometric programming; Dynamic programming, Integer programming, Stochastic programming, Lagrange multiplier method.

##### **UNIT-II: NATURE INSPIRED ALGORITHMS AND GENETIC ALGORITHM**

**(8 periods)**

**Nature Inspired Algorithms:** Traditional vs nature inspired algorithms, Bioinspired algorithms, Swarm intelligence, Metaheuristics, Diversification and intensification, No free lunch theorem, Parameter tuning and control, Algorithm.

**Genetic Algorithm:** Basics, Genetic operators, Example of GA, Algorithm, Schema theory, Prisoner's dilemma problem, Variants and hybrids of GA.

##### **UNIT-III: PARTICLE SWARM, ANT COLONY, BEE COLONY AND CUCKOO SEARCH OPTIMIZATION ALGORITHMS (10 periods)**

**Particle Swarm Optimization:** Swarm behavior, Algorithm, Variants of algorithm.

**Ant Colony Optimization:** Ant colony characteristics, Ant colony optimization – Travelling salesman problem, algorithm; Variants of algorithm.

**Bee Colony Optimization:** Honey bee characteristics, Algorithm, Variants of algorithm.

**Cuckoo Search Algorithm:** Cuckoo bird behavior, Levy flights, Algorithm, Variants of algorithm.

#### **UNIT-IV: FIREFLY, BAT, GRAY WOLF AND ELEPHANT HERDING OPTIMIZATION ALGORITHMS (9 periods)**

**Firefly Algorithm:** Firefly behavior and characteristics, Algorithm, Variants and applications.

**Bat Algorithm:** Behavior of bats in nature, Algorithm, Variants and applications.

**Gray Wolf Optimization:** Gray wolf characteristics, Gray wolf optimization, Variants and applications.

**Elephant Herding Optimization:** Elephant herding behavior, Algorithm, Pseudocode, Variants of the algorithm.

#### **UNIT-V: APPLICATIONS OF NATURE INSPIRED ALGORITHMS (9 periods)**

Image processing, Classification, clustering and feature selection, Traveling salesman problem, Vehicle routing, Scheduling, Software testing, Deep belief networks, Swarm robots, Data mining and deep learning – Clustering, Support vector machines, Artificial neural networks, Optimizers for machine learning, Deep learning.

**Total Periods: 45**

**Topics for self-study are provided in lesson plan**

#### **TEXT BOOKS:**

1. A. Vasuki, *Nature-Inspired Optimization Algorithms*, CRC Press, 2020.
2. Xin-She Yang, *Nature-Inspired Optimization Algorithms*, Elsevier, 2<sup>nd</sup> Edition, 2020.

#### **REFERENCE BOOKS:**

1. Xin-She Yang, Xing-Shi He, *Mathematical Foundations of Nature-Inspired Algorithms*, Springer, 2019.
2. George Lindfield, John Penny, *Introduction to Nature-Inspired Optimization*, Elsevier, 2017.

#### **ADDITIONAL LEARNING RESOURCES:**

- Xin-She Yang, *Nature-Inspired Computation and Swarm Intelligence: Algorithms, Theory and Applications*, Elsevier, 2020.
- Hema Banati, Shikha Mehta, Parmeet Kaur, *Nature-Inspired Algorithms for Big Data Frameworks*, IGI Global, 2019.



**III B. Tech. – II Semester**  
**(19BM60503) MACHINE LEARNING**

Int. Marks	Ext. Marks	Total Marks	L	T	P	C
40	60	100	3	-	-	3

**PRE-REQUISITES: -**

**COURSE DESCRIPTION:** Concept learning, General to specific ordering, Decision tree learning, Support vector machine, Artificial neural networks, Multilayer neural networks, Bayesian learning, Instance based learning, reinforcement learning.

**COURSE OUTCOMES:** After successful completion of the course, students will be able to:

- CO1. Analyze the concept learning algorithms to automatically infer a general description for a given learning problem.
- CO2. Analyze the underlying mathematical models within machine learning algorithms and learning tasks.
- CO3. Evaluate and apply suitable machine learning algorithms for various types of learning tasks.
- CO4. Design efficient neural architectures to model patterns for a given learning problem.
- CO5. Select and apply machine learning algorithms to solve societal problems such as face recognition, text classification.

**DETAILED SYLLABUS:**

**UNIT-I: CONCEPT LEARNING AND GENERAL-TO-SPECIFIC ORDERING (9 periods)**

Well-posed learning problems, Designing a learning system, Perspectives and issues in machine learning, Concept learning task, Concept learning as search, FIND-S, Version spaces and candidate elimination algorithm, Inductive bias.

**UNIT-II: DECISION TREE LEARNING AND KERNEL MACHINES (9 periods)**

**Decision Tree Learning:** Decision tree representation, Problems for decision tree learning, Decision tree learning algorithm, Hypothesis space search, Inductive bias in decision tree learning, Issues in decision tree learning.

**Kernel Machines:** Support vector machines – SVMs for regression, SVMs for classification, Choosing C, A probabilistic interpretation of SVMs.

**UNIT-III: ARTIFICIAL NEURAL NETWORKS (9 periods)**

Neural network representations, Appropriate problems for neural network learning, Perceptrons, Multilayer networks and Backpropagation algorithm, Convergence and local minima, Representational power of feedforward networks, Hypothesis space search and inductive bias, Hidden layer representations, Generalization, Overfitting, Stopping criterion, An Example - Face Recognition.

**UNIT-IV: BAYESIAN LEARNING****(10 periods)**

Bayes theorem and concept learning, Maximum likelihood and least-squared error hypothesis, Maximum likelihood hypotheses for predicting probabilities, Minimum Description Length principle, Bayes optimal classifier, Gibbs algorithm, Naive Bayes classifier, An Example – Learning to classify text; Bayesian belief networks, EM Algorithm.

**UNIT-V: INSTANCE BASED LEARNING AND REINFORCEMENT LEARNING****(8 periods)**

**Instance Based Learning:** k-Nearest Neighbor learning, Locally weighted regression, Radial basis functions, Case-based reasoning.

**Reinforcement Learning:** The learning task, Q-learning, Nondeterministic rewards and actions, Temporal difference learning, Generalizing from examples, Relationship to dynamic programming.

**Total Periods: 45**

**Topics for self-study are provided in the lesson plan**

**TEXT BOOKS:**

1. Tom M. Mitchell, *Machine Learning*, McGraw Hill, 2013.
2. Kevin P. Murphy, *Machine Learning: A Probabilistic Perspective*, MIT Press, 2012.

**REFERENCE BOOKS:**

1. Ethem Alpaydin, *Introduction to Machine Learning*, MIT Press, 4<sup>th</sup> Edition, 2020.
2. Shai Shalev Shwartz, Shai Ben David, *Understanding Machine Learning: From Theory to Algorithms*, Cambridge University Press, 2014.

**ADDITIONAL LEARNING RESOURCES:**

- [https://swayam.gov.in/nd1\\_noc19\\_cs52/preview](https://swayam.gov.in/nd1_noc19_cs52/preview)
- <https://www.udemy.com/course/machinelearning/>

**III B. Tech. – II Semester**  
**(19BM60531) MACHINE LEARNING LAB**

Int. Marks	Ext. Marks	Total Marks	L	T	P	C
50	50	100	-	-	2	1

**PRE-REQUISITES:** Courses on “Programming for Problem Solving”, “Machine Learning”

**COURSE DESCRIPTION:** Implementation of Back propagation algorithm, Decision tree learning, Neural networks, k-NN from scratch algorithm, Naïve Bayes classifier, Radial basis function neural network, SVM based classifier, Maximum likelihood estimation using statistical techniques.

**COURSE OUTCOMES:** After successful completion of the course, students will be able to:

- CO1. Analyze the given problem and identify appropriate machine learning technique to provide an intelligent solution.
- CO2. Design and implement machine learning solutions for classification, regression, and clustering problems.
- CO3. Develop intelligent solutions to solve societal problems related to computer vision, information security, healthcare and other areas.
- CO4. Work independently to solve problems with effective communication.

**LIST OF EXERCISES:**

1. Solve classification problem by constructing a feedforward neural network using Backpropagation algorithm. (Wheat Seed Data)
2. Implement ID3 (information gain) algorithm for decision tree learning for transforming continuous variables into discrete variables.
3. Explore the problem of overfitting in decision tree and develop solution using pruning technique.
4. Build a neural network that will read the image of a digit and correctly identify the number.
5. Implement k-NN algorithm to solve classification problem.
6. Use Naïve Bayes classifier to solve the credit card fraud detection problem over a skewed dataset.
7. Design and implement a radial basis function neural network to solve function approximation or regression problem.
8. Compare and analyze the performance of optimal Bayes classifier and Naïve Bayes using simulated Gaussian Data.
9. Train an SVM based classifier to predict whether the cancer is malignant or benign.
10. Solve the stock price forecasting problem using statistical techniques – Maximum Likelihood estimation after understanding the distribution of the data.

**REFERENCE BOOKS:**

1. Sebastian Raschka, Vahid Mirjalili, *Python Machine Learning*, Packt Publishing, 3<sup>rd</sup> Edition, 2019.
2. Aurelien Geron, *Hands-On Machine Learning with Scikit-Learn, Keras, and TensorFlow: Concepts, Tools, and Techniques to Build Intelligent Systems*, 2<sup>nd</sup> Edition, O'Reilly, 2019.

**SOFTWARE/TOOLS:**

- Python
- Scikit-learn/Keras/TensorFlow

**ADDITIONAL LEARNING RESOURCES:**

- <https://www.coursera.org/learn/machine-learning>
- <https://nptel.ac.in/courses/106106202/>

**IV B. Tech. – I Semester**  
**(19BM70501) DEEP LEARNING**

Int. Marks	Ext. Marks	Total Marks	L	T	P	C
40	60	100	3	-	-	3

**PRE-REQUISITES:** A course on "Machine Learning"

**COURSE DESCRIPTION:** Overview of machine learning; Fundamentals of deep learning; Modern approaches in deep learning; Feedforward neural network architectures; Deep learning Models and Applications.

**COURSE OUTCOMES:** *After successful completion of the course, students will be able to:*

- CO1. Analyze a neural network by applying the basics of mathematics and machine learning.
- CO2. Analyze the data using multilayer perceptron and backpropagation algorithms.
- CO3. Apply regularization and optimization techniques to improve the performance of Deep neural networks.
- CO4. Identify appropriate deep learning model for text, multimedia, and biological data analysis.
- CO5. Compare deep neural networks and deep learning models to infer the suitable learning algorithm on large scale data.
- CO6. Develop a model for domain specific applications by applying various network models in deep learning.

**DETAILED SYLLABUS:**

**UNIT-I: INTRODUCTION**

**(9 Periods)**

Historical Trends in Deep Learning – Machine Learning basics - Learning algorithms: Supervised and Unsupervised Training - Linear Algebra for Machine Learning - Testing - Cross Validation - Dimensionality Reduction - Over fitting /Under Fitting - Hyper parameters and validation sets - Estimators – Bias – Variance - Loss Function- Regularization.

**UNIT-II: NEURAL NETWORKS**

**(9 Periods)**

Biological Neuron – Idea of Computational units - Linear Perceptron - Perceptron Learning Algorithm - Convergence theorem for Perceptron Learning Algorithm - Linear Separability - Multilayer perceptron – Backpropagation.

**UNIT-III: MODERN PRACTICES IN DEEP NETWORKS**

**(10 Periods)**

Introductions to Simple DNN - Platform for Deep Learning - Deep Learning Software Libraries - Deep Feed forward networks – Gradient-Based Learning - Architecture Design –Various Activation Functions, ReLU, Sigmoid – Error Functions - Regularization methods for Deep Learning - Early Stopping - Drop Out - Optimization methods for Neural Networks-Adagrad, Adam.

**UNIT-IV: DEEP LEARNING MODELS****(9 Periods)**

Convolutional Neural Networks (CNNs): CNN Fundamentals – Architectures – Pooling – Visualization – Sequence Modeling: Recurrent Neural Networks (RNN) - Long-Short Term Memory (LSTM) – Bidirectional LSTMs-Bidirectional RNNs -Deep Unsupervised Learning: Autoencoders – Auto Encoder Applications -Deep Boltzmann Machine (DBM).

**UNIT-V: CASE STUDY AND APPLICATIONS****(8 Periods)**

Application Case Study - Handwritten digits recognition using deep learning - LSTM with Keras – Sentiment Analysis – Image Dimensionality Reduction using Encoders LSTM with Keras – Alexnet – VGGnet.

**Total Periods: 45****Topics for self-study are provided in the lesson plan****TEXT BOOK:**

1. Ian Goodfellow, Yoshua Bengio, Aaron Courville, *Deep Learning*, 4<sup>th</sup> Edition, MIT Press, 2016.

**REFERENCE BOOKS:**

1. Kevin P. Murphy, *Machine Learning: A Probabilistic Perspective*, MIT Press, 2012.
2. Michael A. Nielsen, *Neural Networks and Deep Learning*, Determination Press, 2015.
3. Deng & Yu, *Deep Learning: Methods and Applications*, Now Publishers, 2013.

**ADDITIONAL RESOURCES:**

1. [https://www.youtube.com/watch?reload=9&v=aPfkYu\\_qiF4](https://www.youtube.com/watch?reload=9&v=aPfkYu_qiF4)
2. <http://www.deeplearning.net/tutorial/>
3. <https://www.guru99.com/deep-learning-tutorial.html>
4. <https://www.coursera.org/courses?query=deep%20learning>

**IV B. Tech. – I Semester**  
**(19BM70531) DEEP LEARNING LAB**

Int.	Ext.	Total Marks	L	T	P	C
50	50	100	-	-	2	1

**PRE-REQUISITES:** A Course on “Deep Learning”

**COURSE DESCRIPTION:** Implementation of deep learning architectures, Modern approaches in deep learning, Feedforward neural network architectures, Deep learning models and applications.

**COURSE OUTCOMES:** After successful completion of the course, students will able to:

- CO1. Identify optimal hyperparameter values and appropriate architecture for a given problem and data using optimization techniques.
- CO2. Analyze the characteristics of the given data and perform necessary pre-processing tasks to structure the data using Python libraries.
- CO3. Utilize Python machine learning libraries and packages for building deep neural architectures to solve AI problems.
- CO4. Work independently to solve problems with effective communication.

**LIST OF EXERCISES:**

1. Perform splitting of data for training, testing, and validation using k-fold cross validation.
2. Construct and implement multi-layer feed forward neural network for hand written digit classification problem.
3. Implement a binary and multi class image classification using Convolution Neural Network.
4. Perform hyper parameter tuning using Bayesian optimization technique for a Convolution Neural Network.
5. Analyze the effectiveness of various optimization algorithms with an image classification problem.
6. Solve the overfitting problem in a neural architecture using DropOut technique.
7. Study the efficiency of the transfer learning approach for a classification problem on the following architectures; VGG-16, Alexnet, and Inception-V3.
8. Solve a seq2seq problem (machine translation) using LSTM Recurrent Neural Architecture.
9. Solve a time series forecasting (stock prediction) using LSTM RNN.
10. Implement the image dimensionality reduction problem using a AutoEncoder architecture.

**REFERENCE BOOKS:**

1. Ian Goodfellow, Yoshua Bengio and Aaron Courville, *Deep Learning*, MIT Press, 2016.
2. S Lovelyn Rose, L Ashok Kumar, D Karthika Renuka, *Deep Learning Using Python*, Wiley, 2019.

3. François Chollet, *Deep Learning with Python*, Manning Publications, 2017.
4. Jojo Moolayil, *Learn Keras for Deep Neural Networks: A Fast-Track Approach to Modern Deep Learning with Python*, Apress, 2018.

**SOFTWARE/TOOLS:**

- Environment: Google CoLab
- Programming Language: Python 3.8
- Machine Learning Library: Tensor Flow 2.1 and Keras

**ADDITIONAL LEARNING RESOURCES:**

- Bharath Ramsundar, Reza Bosagh Zadeh, *TensorFlow for Deep Learning*, O'reilly, 2018.
- <https://www.coursera.org/professional-certificates/tensorflow-in-practice>
- <https://www.coursera.org/learn/introduction-tensorflow>



## **MINOR DEGREE IN INTERNET OF THINGS**

**Offering Department:** INFORMATION TECHNOLOGY

**Students of Eligible Branches:** CSE, CSSE, ECE, EEE, EIE, ME and CE

### **COURSE STRUCTURE**

Year & Semester	Course Code	Course Title	Contact Periods per week				C	Scheme of Examination Max. Marks		
			L	T	P	Total		Int. Marks	Ext. Marks	Total Marks
III B.Tech. I-Sem (2 Theory + 1 Lab)	19BM51201	Embedded System Design and Architecture	3	-	-	3	3	40	60	100
	19BM51202	IoT Architecture and Protocols	3	-	-	3	3	40	60	100
	19BM51203	Sensor Technologies	3	-	-	3	3	40	60	100
	19BM51231	Sensors based IoT Lab	-	-	2	2	1	50	50	100
III B.Tech. II-Sem (2 Theory + 1 Lab)	19BM61201	Cloud Storage and Computing	3	-	-	3	3	40	60	100
	19BM61202	Privacy and Security in IoT	3	-	-	3	3	40	60	100
	19BM61203	Software Defined Networks for IoT	3	-	-	3	3	40	60	100
	19BM61231	IoT Application Development Lab	-	-	2	2	1	50	50	100
IV B.Tech. I-Sem (1 Theory + 1 Lab)	19BM71201	Advanced IoT	3	-	-	3	3	40	60	100
	19BM71202	Big Data Analytics for IoT	3	-	-	3	3	40	60	100
	19BM71231	Advanced IoT Lab	-	-	2	2	1	50	50	100

**Note:** If any student has chosen a course from the above list in their regular curriculum then, he/she is not eligible to opt the same course/s for the Minor degree. It is the responsibility of the student to acquire/complete prerequisite before taking the respective course.

### III B. Tech. – I Semester

#### (19BM51201) **EMBEDDED SYSTEM DESIGN AND ARCHITECTURE**

Int. Marks	Ext. Marks	Total Marks	L	T	P	C
40	60	100	3	-	-	3

#### **PRE-REQUISITES:--**

**COURSE DESCRIPTION:** Concepts of Embedded systems and its computing; The programming of 8051; The Embedded C and Applications; Applications of RTOS and Embedded Software Development Tools; The ARM and SHARC Processor's Architectures.

**COURSE OUTCOMES:** After successful completion of the course, students will be able to:

- CO1. Demonstrate knowledge on Fundamental concepts of Embedded Systems in Real-time.
- CO2. Demonstrate programming skills using 8051.
- CO3. Develop the Embedded Systems applications.
- CO4. Demonstrate knowledge on RTOS concepts and Embedded Software Development Tools through RTOS.
- CO5. Demonstrate knowledge on advanced processors architecture such as ARM and SHARC and the bus protocols such as I2C and CAN bus.

#### **DETAILED SYLLABUS:**

##### **UNIT-I: INTRODUCTION TO EMBEDDED COMPUTING (08 Periods)**

Definition of embedded system, embedded systems vs. general computing systems, history of embedded systems, complex systems and microprocessor, classification, major application areas, the embedded system design process, formalisms for system design, design examples

##### **UNIT-II: THE 8051 ARCHITECTURE (09 Periods)**

Introduction, 8051 Micro controller Hardware, Input/output Ports and Circuits, External Memory, Counter and Timers, Serial data Input/output, Interrupts. The Assembly Language Programming Process, Instructions of 8051 Programming Tools and Techniques, Simple Programs.

##### **UNIT-III: INTRODUCTION TO EMBEDDED C AND APPLICATIONS (10 Periods)**

Embedded systems programming in C, binding and running embedded C program in Keil IDE, dissecting the program, building the hardware. Basic techniques for reading and writing from I/O port pins, LED interfacing, interfacing with keyboards, displays, D/A and A/D conversions, using embedded C interfacing.

#### **UNIT-IV: INTRODUCTION TO REAL – TIME OPERATING SYSTEMS (10 Periods)**

Tasks and Task States, Semaphores, and Shared Data; Message Queues, Mailboxes and Pipes, Timer Functions, Events, Semaphores and Queues, Hard Real-Time Scheduling Considerations, Interrupt Routines in an RTOS Environment.

**EMBEDDED SOFTWARE DEVELOPMENT TOOLS:** Host and Target machines, Linker/Locators for Embedded Software, Getting Embedded Software into the Target System; Debugging Techniques: Testing on Host Machine.

#### **UNIT-V: INTRODUCTION TO ADVANCED ARCHITECTURES (08 Periods)**

ARM and SHARC, Processor and memory organization and Instruction level parallelism; Networked embedded systems: Bus protocols, I2C bus and CAN bus.

**Total Periods: 45**

**Topics for self-study are provided in lesson plan**

#### **TEXT BOOKS:**

1. Wayne Wolf, *Principles of Embedded Computing System Design*, 2<sup>nd</sup> Edition, Elsevier, 2014.
2. Kenneth J. Ayala, *The 8051 Microcontroller*, Thomson, 2<sup>nd</sup> Edition, 2016.

#### **REFERENCE BOOKS:**

1. David E. Simon, *An Embedded Software Primer*, Pearson Education, 2009.
2. Dr. KVKKPrasad, *Embedded/Real-Time Systems: Concepts, Design And Programming*, Black Book, DreamTech Press, 2003.

#### **ADDITIONAL LEARNING RESOURCES:**

##### **Web References:**

1. <https://www.smartzworld.com/notes/embedded-systems-es/>
2. <http://notes.specworld.in/embedded-systems-es/>
3. <http://education.uandistar.net/jntu-study-materials>
4. <http://www.nptelvideos.in/2012/11/embedded-systems.html>

##### **E-TextBooks:**

1. <https://www.scribd.com/doc/233633895/Intro-to-Embedded-Systems-by-Shibu-Kv>
2. [http://www.ee.eng.cmu.ac.th/~demo/think/\\_DXJSq9r3TvL.pdf](http://www.ee.eng.cmu.ac.th/~demo/think/_DXJSq9r3TvL.pdf)
3. <https://www.scribd.com/doc/55232437/Embedded-Systems-Raj-Kamal>
4. [https://docs.google.com/file/d/0B6CytI4eS\\_ahUS1LTkVXb1hxa00/edit](https://docs.google.com/file/d/0B6CytI4eS_ahUS1LTkVXb1hxa00/edit)

### III B. Tech. – I Semester

#### (19BM51202) **IoT ARCHITECTURE AND PROTOCOLS**

Int. Marks	Ext. Marks	Total Marks	L	T	P	C
40	60	100	3	-	-	3

**PRE-REQUISITES:** --

#### **COURSE DESCRIPTION:**

M2M to IoT An Architectural Overview and M2M and IoT Technology Fundamentals, IoT Architecture State of the Art, IoT Reference Architecture and Real-World Design Constraints, IoT Data Link Layer & Network Layer Protocols, Session Layer Protocols and Application Layer Protocols, Security in IoT Protocols and Case studies.

**COURSE OUTCOMES:** After successful completion of this course, the students will be able to:

- CO1 Demonstrate knowledge on architecture and technology of M2M to IoT.
- CO2 Demonstrate knowledge on IoT architectures and identify design constraints of IoT.
- CO3 Select suitable protocols of data link and network layer protocols for different applications of IoT.
- CO4 Identify appropriate protocols of session and application layer protocols for different applications of IoT.
- CO5 Evaluate security issues and challenges during implementation of real world models.

#### **DETAILED SYLLABUS:**

##### **UNIT-I: (9 Periods)**

**M2M TO IoT AN ARCHITECTURAL OVERVIEW:** Building architecture, Main design principles and needed capabilities, An IoT architecture outline, Standards considerations.

**M2M AND IoT TECHNOLOGY FUNDAMENTALS:** Devices and gateways, Local and wide area networking, Data management, Business processes in IoT, Everything as a service (XaaS), M2M and IoT analytics, Knowledge management.

##### **UNIT II: (9 Periods)**

**IoT ARCHITECTURE STATE OF THE ART:** Introduction, State of the art, Architecture Reference Model- Reference model and architecture, IoT reference model.

**IoT REFERENCE ARCHITECTURE:** Functional view, Functional view, Deployment and operational view, Other relevant architectural views

**REAL-WORLD DESIGN CONSTRAINTS:** Technical design constraints hardware is popular again, Data representation and visualization, Interaction and remote control

##### **UNIT III: (9 Periods)**

**IoT DATA LINK LAYER:** IEEE 802.15.4, IEEE 802.11ah, LoRaWAN, Z-Wave, Bluetooth Low Energy, Zigbee Smart Energy; **Network Layer Encapsulation Protocols:** 6LoWPAN, 6TiSCH, 6Lo;

**NETWORK LAYER ROUTING PROTOCOLS:**RPL, CORPL, CARP.

**UNIT IV:****(10 Periods)****SESSION LAYER PROTOCOLS:** MQTT, AMQP, CoAP, XMPP, DDS;**APPLICATION LAYER PROTOCOLS:** SCADA, Generic Web-Based Protocol.**UNIT V:****(8 Periods)****SECURITY IN IoT PROTOCOLS:** MAC 802.15.4, 6LoWPAN, RPL, IoT Challenges**CASE STUDIES:** Smart Metering, Smart House, Smart Cities**Total Periods: 45*****Topics for self-study are provided in lesson plan*****TEXT BOOKS:**

1. Jan Holler and Vlasios Tsiatsis, *From Machine-to-Machine to the Internet of Things Introduction to a New Age of Intelligence*, Elsevier, 2014.
2. David Hanes and Gonzalo Salgueiro, *IoT Fundamentals: Networking Technologies, Protocols, and Use Cases for the Internet of Things*, Cisco Press, 2017

**REFERENCE BOOKS:**

1. Peter Waher, *Learning Internet of Things*, PACKT publishing, 2015.
2. Olivier Hersent and David Boswarthick, *The Internet of Things Key Applications and Protocols*, John Wiley & Sons Ltd Publication, 2012.

**ADDITIONAL LEARNING RESOURCE:**

1. [http://www.cse.wustl.edu/~jain/cse570-15/ftp/iot\\_prot/index.html](http://www.cse.wustl.edu/~jain/cse570-15/ftp/iot_prot/index.html)

### III B. Tech. – I Semester

#### (19BM51203) SENSOR TECHNOLOGIES

Int. Marks	Ext. Marks	Total Marks	L	T	P	C
40	60	100	3	-	-	3

**PRE-REQUISITES:** A course on Physics.

**COURSE DESCRIPTION:** Sensor fundamentals and characteristics, Optical Sources and Detectors; Intensity Polarization and Interferometric Sensors, Phase sensor, Strain, Force, Torque and Pressure sensors; Position, Direction, Displacement and Level sensors, Velocity and Acceleration sensors, Electromagnetic velocity sensor, Light and Sound Sensors; Flow, Temperature and Acoustic sensors; Wearable Sensors.

**COURSE OUTCOMES:** *After successful completion of this course, the student will be able to:*

- CO1. Demonstrate knowledge on the characteristics of Sensors and principles of Optical Sources and Detectors.
- CO2. Apply the principles of Intensity Polarization, Interferometric, Phase, Strain, Force, Torque and Pressure sensors in Sensor applications.
- CO3. Apply the principles of Position, Direction, Displacement, Level, Velocity and Acceleration, Electromagnetic velocity, Sound and Light Sensors in Sensor applications.
- CO4. Analyze the principles of Flow, Temperature and Acoustic sensors to build Sensor applications.
- CO5: Analyze the principles of Wearable Sensors and identify suitable sensors for real time applications.

#### **DETAILED SYLLABUS:**

##### **UNIT-I:**

**(9 Periods)**

**SENSOR FUNDAMENTALS AND CHARACTERISTICS:** Sensor Classification, Performance and Types, Error Analysis characteristics,

**OPTICAL SOURCES AND DETECTORS:** Electronic and Optical properties of semiconductor as sensors, LED, Semiconductor lasers, Fiber optic sensors, Thermal detectors, Photo multipliers, photoconductive detectors, Photo diodes, Avalanche photodiodes, CCDs.

##### **UNIT-II:**

**(9 Periods)**

**INTENSITY POLARIZATION AND INTERFEROMETRIC SENSORS:** Intensity sensor, Microbending concept, Interferometers, Mach Zehnder, Michelson, FabryPerot and Sagnac.

**PHASE SENSOR:** Phase detection, Polarization maintaining fibers.

**STRAIN, FORCE, TORQUE AND PRESSURE SENSORS:** Strain gages, strain gage beam force sensor, piezoelectric force sensor, load cell, torque sensor, Piezo-resistive and capacitive pressure sensor, optoelectronic pressure sensors, vacuum sensors.

**UNIT-III:****(9 Periods)**

**POSITION, DIRECTION, DISPLACEMENT AND LEVEL SENSORS:** Potentiometric and capacitive sensors, Inductive and magnetic sensor, LVDT, RVDT, eddy current, transverse inductive, Hall effect, magneto resistive, magneto strictive sensors.

Fiber optic liquid level sensing, Fabry Perot sensor, ultrasonic sensor, capacitive liquid level sensor.

**VELOCITY AND ACCELERATION SENSORS:**

Electromagnetic velocity sensor, Doppler with sound, light, Accelerometer characteristics, capacitive, piezo-resistive, piezoelectric accelerometer, thermal accelerometer, rotor, monolithic and optical gyroscopes.

**UNIT-IV:****(9 Periods)**

**FLOW SENSORS:** pressure gradient technique, thermal transport, ultrasonic, electromagnetic and Laser anemometer. microflow sensor, coriolis mass flow and drag flow sensor.

**TEMPERATURE SENSORS:** thermoresistive, thermoelectric, semiconductor and optical. Piezoelectric temperature sensor.

**ACOUSTIC SENSORS:** microphones-resistive, capacitive, piezoelectric, fiber optic, solid state electret microphone.

**UNIT-V: WEARABLE SENSORS****(9 Periods)**

From fibers to textile sensors - Interlaced network -Textile sensors for physiological state monitoring - Biomechanical sensing - Noninvasive sweat monitoring by textile sensors and other applications. FBG sensor in Intelligent Clothing and Biomechanics.

**Total Periods: 45**

***Topics for self-study are provided in lesson plan***

**TEXT BOOKS:**

1. J. Fraden, *Handbook of Modern Sensors: Physical, Designs, and Applications*, AIP Press, 2004.
2. Patranabis, *Sensors and Transducers*, PHI Publication, 2<sup>nd</sup> Edition, 2014.

**REFERENCE BOOKS:**

1. Patranabis D, *Principles of Industrial Instrumentation*, Tata McGrawHill, End edition, 1997
2. Ganesh S. Hegde, *Mechatronics*, Published by University Science Press, 2008.

### III B. Tech. –I Semester

#### (19BM51231) SENSOR BASED IoT LAB

Int. Marks	Ext. Marks	Total Marks	L	T	P	C
50	50	100	-	-	2	1

#### PRE-REQUISITES: --

**COURSE DESCRIPTION:** Hands-on experience on connecting IoT devices using Sensors, Arduino/Raspberry Pi, Bread Board.

**COURSE OUTCOMES:** *After successful completion of the course, students will be able to:*

- CO1. Identify different types of Sensors and study their functionality in IoT
- CO2. Demonstrate skills in connecting peripherals to Arduino/Raspberry Pi for data exchange.
- CO3. Develop a Cloud platform to upload and analyze any sensor data
- CO4. Demonstrate skills in connecting GSM, GPS, Gateways to micro controllers and perform Data Management in IoT.
- CO5. Build a complete working IoT system involving prototyping, programming and data analysis.
- CO6. Work independently or in teams to solve problems with effective communication.

#### LIST OF EXPERIMENTS:

1. Study of Different types of Sensors and Introduction to Arduino platform and programming.
2. Interfacing Arduino to Zigbee module.
3. Interfacing Arduino to GSM module and Bluetooth Module.
4. Introduction to Raspberry PI platform and python programming.
5. Interfacing sensors to Raspberry PI.
6. Communicate between Arduino and Raspberry PI using any wireless medium.
7. Log Data using Raspberry PI and upload to the cloud platform.
8. Design an IoT based system.

#### REFERENCE BOOKS:

1. Arshdeep Bahga, Vijay Madiseti, *Internet of Things- A hands on approach*, 1<sup>st</sup> edition, VPI publications, 2014.
2. Adrian McEwen, Hakin Cassimally, *Designing the Internet of Things*, Wiley India, 2013



3. Massimo Banzi and Michael Shiloh, *Getting Started with Arduino*, 3<sup>rd</sup> Edition, Maker Media, 2015
4. *Getting Started with Raspberry pi*, Matt Richardson & Shawn Wallace, O'Reilly, 2014.

### III B. Tech. –II Semester

#### (19BM61201) CLOUD STORAGE AND COMPUTING

Int. Marks	Ext. Marks	Total Marks	L	T	P	C
40	60	100	3	-	-	3

#### PRE-REQUISITES: --

**COURSE DESCRIPTION:** Introduction to Cloud Computing, Data Storage Networking fundamentals, Cloud Services and Platforms, Cloud Application Design.

**COURSE OUTCOMES:** *After successful completion of the course, students will be able to:*

- CO1. Demonstrate basic concepts and terminologies of Cloud Computing, Cloud-based Services and Applications.
- CO2. Demonstrate Cloud, Virtualization and Data Storage Networking concepts.
- CO3. Analyze Cloud Services, Platforms and Applications.
- CO4. Apply different Cloud Services and Platforms to construct Cloud applications.
- CO5. Design Cloud applications as per societal needs through different design approaches.

#### DETAILED SYLLABUS

##### UNIT-I: INTRODUCTION TO CLOUD COMPUTING (9 Periods)

Introduction, Characteristics of Cloud Computing. Cloud Models, Cloud Services Examples, Cloud-based Services and Applications.

##### UNIT-II: (9 Periods)

**CLOUD CONCEPTS AND TECHNOLOGIES:** Virtualization, Load Balancing, Scalability and Elasticity, Deployment, Replication, Monitoring, Software Defined Networking, Network Function Virtualization, MapReduce, Identity and Access Management, Service Level Agreements and Billing.

**DATA STORAGE FUNDAMENTALS:** Server and I/O Architectures, Storage Hierarchy, From Bits to Bytes, Disk Storage Fundamentals, Initiators and Targets, How Data Is Written to and Read from a Storage Device, Storage Sharing vs. Data Sharing, Different Types of Storage.

##### UNIT-III: CLOUD SERVICES AND PLATFORM -I (9 Periods)

Amazon Elastic Compute Cloud, Google Compute Engine, Windows Azure Virtual Machines, Amazon Simple Storage Service, Google Cloud Storage, Windows Azure Storage, Amazon Relational Data Store, Amazon DynamoDB, Google Cloud SQL, Google Cloud Datastore, Windows Azure SQL Database and Windows Azure Table Service.

##### UNIT-IV: CLOUD SERVICES AND PLATFORM -II (9 Periods)

Application Runtimes and Framework, Queuing Services, Email Services, Notification Services, Media Services, Amazon CloudFront, Windows Azure Content Delivery Network, Amazon Elastic MapReduce, Google MapReduce Service, Google BigQuery, Amazon Elastic Beanstalk and Amazon CloudFormation.

**UNIT-V: CLOUD APPLICATION DESIGN****(9 Periods)**

Introduction, Design Considerations for Cloud Applications, Reference Architectures for Cloud Applications, Cloud Application Design Methodologies and Data Storage Approaches.

**Total Periods: 45**

*Topics for self-study are provided in lesson plan*

**TEXT BOOKS:**

1. ArshdeepBahga and Vijay Madiseti, *Cloud Computing – A Hands-on Approach*, Universities Press (India) Private Limited, 2014.
2. Greg Schulz, *Cloud and VirtualData StorageNetworking*, CRC PressTaylor & Francis Group, 2012.

**REFERENCE BOOKS:**

1. Barrie Sosinsky, *Cloud Computing Bible*, Wiley India Pvt Ltd, 2011 (Reprint 2017).
2. Thomas Erl and RicardoPuttini, *Cloud Computing- Concepts, Technology and Architecture*, Pearson, 2014 (Seventh Impression 2017).

**ADDITIONAL LEARNING RESOURCES:**

1. "Exploring the Google Toolkit", <https://code.google.com/>, drafted on 21 June, 2021.
2. "Understanding Amazon Web Services", <https://aws.amazon.com/>, drafted on 21 June, 2021.

### III B. Tech. –II Semester

#### (19BM61202) **PRIVACY AND SECURITY IN IoT**

Int. Marks	Ext. Marks	Total Marks	L	T	P	C
40	60	100	3	-	-	3

**PRE-REQUISITES:** A Course on Internet of Things Lab.

**COURSE DESCRIPTION:** Introduction of IoT; Securing The Internet Of Things; Cryptographic Fundamentals for IoT; Identity & Access Management Solutions for IoT; Privacy Preservation And Trust Models for IoT; Cloud Security for IoT;

**COURSE OUTCOMES:** *After successful completion of the course, students will be able to:*

CO1. Demonstrate knowledge on Security issues of IoT.

CO2. Apply Cryptographic Principles for IoT Security.

CO3. Identify suitable Access Management Solutions for IoT.

CO4. Apply Privacy Preservation and Trust Models for IoT.

CO5. Demonstrate knowledge on Cloud Security for IoT.

#### **DETAILED SYLLABUS:**

#### **UNIT I- INTRODUCTION: SECURING THE INTERNET OF THINGS (9 periods)**

Security Requirements in IoT Architecture, Security in Enabling Technologies, Security Concerns in IoT Applications; Security Architecture in the Internet of Things, Security Requirements in IoT, Insufficient Authentication/Authorization, Insecure Access Control, Threats to Access Control, Privacy, and Availability, Attacks Specific to IoT; Vulnerabilities, Secrecy and Secret-Key Capacity, Authentication/Authorization for Smart Devices; Transport Encryption; Attack & Fault trees

#### **UNIT II – CRYPTOGRAPHIC FUNDAMENTALS FOR IoT (9 periods)**

Cryptographic primitives and its role in IoT, Encryption and Decryption, Hashes, Digital Signatures, Random number generation, Cipher suites, key management fundamentals, cryptographic controls built into IoT messaging and communication protocols, IoT Node Authentication.

#### **UNIT III – IDENTITY & ACCESS MANAGEMENT SOLUTIONS FOR IoT (9 periods)**

Identity lifecycle, authentication credentials, IoT IAM infrastructure; Authorization with Publish/Subscribe schemes; access control.

#### **UNIT IV – PRIVACY PRESERVATION AND TRUST MODELS FOR IoT (9 periods)**

Concerns in data dissemination, Lightweight and robust schemes for Privacy protection, Trust and Trust models for IoT, self-organizing Things, Preventing unauthorized access

**UNIT V – CLOUD SECURITY FOR IoT****(9 periods)**

Cloud services and IoT - offerings related to IoT from cloud service providers, Cloud IoT security controls; An enterprise IoT cloud security architecture – New directions in cloud enabled IoT computing.

**Total Periods: 45*****Topics for self-study are provided in lesson plan*****TEXT BOOK:**

1. Brian Russell, Drew Van Duren, *Practical Internet of Things Security*, Kindle Edition, 2016.

**REFERENCE BOOK:**

1. Fei Hu, *Security and Privacy in Internet of Things (IoTs)- Models, Algorithms, and Implementations*, CRC Press, 1<sup>st</sup> Edition, 2016

**ADDITIONAL LEARNING RESOURCES:**

1. <https://www.fortinet.com/resources/cyberglossary/iot-security>

**III B. Tech. –II Semester**  
**(19BM61203) SOFTWARE DEFINED NETWORKS FOR IoT**

Int. Marks	Ext. Marks	Total Marks	L	T	P	C
40	60	100	3	-	-	3

**PRE-REQUISITES:** A Course on Internet of Things Lab.

**COURSE DESCRIPTION:** Packet Switching Terminology, Traditional Switch architecture, Fundamental Characteristics of SDN, SDN Controller, SDN Applications, SDN in the data center, Use Cases in the Data Center, Scope of the Internet of Things, SDN for IoT.

**COURSE OUTCOMES:** After successful completion of the course, students will be able to:

- CO1. Demonstrate knowledge on characteristics of Data center and Network Technologies.
- CO2. Demonstrate skills on Operating and performing Data flow in Software Defined Networks
- CO3. Identify suitable Data Center topologies for virtualized environment.
- CO4. Apply Software defined Networks concepts for the Internet of Things
- CO5. Apply suitable addressing schemes and routing protocols to achieve QoS in SDN based IoT.

**DETAILED SYLLABUS:**

**UNIT- I: INTRODUCTION TO SOFTWARE DEFINED NETWORKS (9 Periods)**

Basic Packet-Switching Terminology, The Modern Data Center, Traditional Switch architecture, Autonomous and Dynamic Forwarding Tables, Evolution of Switches and Control Planes ,SDN Implications for Research and Innovation, Data Center Innovation, Data Center Needs, The Evolution of Networking Technology, Forerunners of SDN, Software Defined Networking is Born, Sustaining SDN Interoperability, Open Source Contributions, Legacy Mechanisms Evolve Toward SDN, Network Virtualization.

**UNIT- II: FUNDAMENTAL CHARACTERISTICS OF SDN (9 Periods)**

SDN Operation, SDN Devices, SDN Controller, SDN Applications, Alternate SDN Methods, OpenFlow, OpenFlow Limitations, Potential Drawbacks of Open SDN,SDN via APIs, SDN via Hypervisor-Based Overlays, SDN via Opening Up the Device, Network Functions Virtualization, Alternatives Overlap and Ranking. Real-World Data Center Implementations, applications and SDN features.

**UNIT-III: SDN IN THE DATA CENTER (9 Periods)**

Data Center Definition, Data Center Demands, Tunneling Technologies for the Data Center, Path Technologies in the Data Center, Ethernet Fabrics in the Data Center, SDN Use Cases in the Data Center, Open SDN versus Overlays in the Data Center.

**UNIT-IV: THE INTERNET OF THINGS (9 Periods)**

Scope of the Internet of Things, Key Features of IoT Data, Technical requests for Openstack as a IoT-Cloud Platform, Feature of Message Broking, IoT architecture in NTT DATA, IoT architecture on Openstack, Endpoint-Aware Service Function Chaining, Service function chaining for the IoT data plane, Mobile Network Slicing for IoT, Introduction to IoTivity.

**UNIT- V: SDN for IoT:****(9 Periods)**

SDN based IoT, IoT Host Management System Architecture, Network Topology, Experiment Environment, Host Address collection, Host blocking, Host address translation, Dynamic QoS Routing Algorithm in SDN, SDN based Dynamic QoS Routing Framework, Mobility Support in SDN IoT networks, SDN and Cloud based Forest Fire Detection System using IoT devices.

**Total Periods: 45*****Topics for self-study are provided in lesson plan*****TEXT BOOKS:**

1. Paul Goransson and Chuck Balck, *Software Defined Networks -A comprehensive Approach*, 1<sup>st</sup> Edition, 2014.
2. Sunyoung Han, *Software Defined Network for Internet of Things*, Chulalongkorn University, Thailand, 2016.

**REFERENCE BOOKS:**

1. William Stallings, *Foundations of Modern Networking: SDN, NFV, QoE, IoT, and Cloud*, Addison-Wesley, 2015.
2. Jim Doherty, *SDN and NFV Simplified: A Visual Guide to Understanding Software Defined Networks and Network Function Virtualization*, Pearson, 2017.

### III B. Tech. –II Semester

#### (19BM61231) IoT APPLICATION DEVELOPMENT LAB

Int. Marks	Ext. Marks	Total Marks	L	T	P	C
50	50	100	-	-	2	1

**PRE-REQUISITES:** A course on Internet of Things Lab.

**COURSE DESCRIPTION:** Hands-on practice on Internet of Things (IoT); Usage of Sensors, Arduino microcontroller and Raspberry Pi microprocessor; Development of IoT Applications for societal needs; IoT with Cloud environments.

**COURSE OUTCOMES:** *After successful completion of the course, students will be able to:*

- CO1. Demonstrate hands-on experience on IoT.
- CO2. Use Sensors, Arduino microcontroller and Raspberry Pi microprocessor for the development of IoT applications.
- CO3. Analyze the user requirements for the development of IoT applications.
- CO4. Develop IoT applications to solve societal problems using cloud environment.
- CO5. Work independently or in teams to solve problems with effective communication.

#### **LIST OF EXPERIMENTS:**

1. Develop an IoT application to control servo motor using Arduino/Raspberry Pi.
2. Develop an IoT application using Arduino/Raspberry Pi for fire alarm.
3. Develop an IoT application to measure temperature, humidity, light and distance using Arduino/Raspberry Pi.
4. Develop an IoT application to control home appliances using a smart phone.
5. Develop an IoT application to measure soil moisture, air and water quality using Arduino/Raspberry Pi.
6. Develop an IoT application to control and monitor Street lights using Arduino/Raspberry Pi.
7. Develop an IoT application to detect obstacles using Arduino/Raspberry Pi.
8. Develop an IoT application using Arduino/Raspberry Pi to monitor heartbeat, blood pressure, etc. of a person and to upload health information to thingspeak cloud.
9. Develop an Alexa based Home Automation System using IoT.

#### **REFERENCE BOOKS:**

1. Arshdeep Bahga and Vijay Madisetti, *Internet of Things( A hands on approach)*, 1<sup>st</sup> Edition, VPI Publications, 2014.
2. Adrian McEwen and Hakin Cassimally, *Designing the Internet of Things*, Wiley India.



3. Massimo Banzi and Michael Shiloh, *Getting Started with Arduino*, Third Edition, Maker Media.
4. Matt Richardson and Shawn Wallace, *Getting Started with Raspberry Pi*, O'Reilly, 2014.

**IV B. Tech. - I Semester**  
**(19BM71201) ADVANCED IoT**

Int. Marks	Ext. Marks	Total Marks	L	T	P	C
40	60	100	3	-	-	3

**PRE-REQUISITES:** A course on Internet of Things Lab.

**COURSE DESCRIPTION:** Introduction to the Industrial Internet; Industrial Internet Use-Cases; Technical and Business Innovators of the Industrial Internet; IIoT Reference Architecture, Designing Industrial Internet Systems; Examining the Access Network Technology & Protocols; Examining the Middleware Transport Protocols; Middleware Software Patterns; Middleware Industrial Internet of Things Platforms; IIoT WAN Technologies and Protocols; Securing the Industrial Internet; Introducing Industry 4.0; Smart Factories.

**COURSE OUTCOMES:** After successful completion of the course, students will be able to:

- CO1. Demonstrate knowledge on IIoT Concepts, applications, Technical requirements.
- CO2. Design and develop IIoT applications, using different architectures and protocols.
- CO3. Identify suitable middleware Transport Protocols, and Software Patterns to design APIs and Platforms.
- CO4. Demonstrate knowledge on WAN Technologies & Protocols and security management in IIoT.
- CO5. Demonstrate knowledge on Industry 4.0 and smart factories

**DETAILED SYLLABUS:**

**UNIT-I:**

**(9 Periods)**

**INTRODUCTION TO THE INDUSTRIAL INTERNET:** What is IIoT, Key IIoT Technologies Catalysts and Precursors of the IIoT, Innovation and the IIoT, Key Opportunities and Benefits, The Digital and Human Workforce.

**INDUSTRIAL INTERNET USE-CASES:** Healthcare, Oil and Gas Industry, Smart Office, Logistics and the Industrial Internet, Retail

**THE TECHNICAL AND BUSINESS INNOVATORS OF THE INDUSTRIAL INTERNET:** Miniaturization, Cyber Physical Systems (CPS), Wireless Technology, IP Mobility, Network Functionality Virtualization(NFV), Network Virtualization, The Cloud and Fog, Big Data and Analytics, M2M Learning and Artificial Intelligence, Augmented Reality, 3D Printing, People versus Automation

**UNIT-II:**

**(9 Periods)**

**IIoT REFERENCE ARCHITECTURE:** The IIC Industrial Internet Reference Architecture, Industrial Internet Architecture Framework (IIAF), Architectural Topology, The Three-Tier Topology, Connectivity, Key System Characteristics, Data Management.

**DESIGNING INDUSTRIAL INTERNET SYSTEMS:** The Concept of the IIoT, The Proximity Network, WSN

Edge Node, Legacy Industrial Protocols, Modern Communication Protocols, Wireless

Communication Technologies, Proximity Network Communication Protocols, Gateways

**EXAMINING THE ACCESS NETWORK TECHNOLOGY AND PROTOCOLS:** The Access Network, Access Networks Connecting Remote Edge Networks

**UNIT-III:**

**(9 Periods)**

**EXAMINING THE MIDDLEWARE TRANSPORT PROTOCOLS:** TCP/IP, UDP, Reliable Transport Protocol (RTP), CoAP (Constrained Application Protocol).

**MIDDLEWARE SOFTWARE PATTERNS:** Publish/Subscribe Pattern: MQTT, XMPP, AMQP, DDS, Delay Tolerant Networks (DTN).

**SOFTWARE DESIGN CONCEPTS:** API (Application Programming Interface), API: A Technical Perspective, Web Services.

**MIDDLEWARE INDUSTRIAL INTERNET OF THINGS PLATFORMS:** Middleware Architecture, IIoT Middleware Platforms.

**UNIT-IV:**

**(9 Periods)**

**IIoT WAN TECHNOLOGIES AND PROTOCOLS:** IIoT Device Low-Power WAN Optimized Technologies for M2M, Low Power Wi-Fi, LTE Category-M, Weightless, Millimeter Radio.

**SECURING THE INDUSTRIAL INTERNET:** Security in Manufacturing: PLCs and DCS, Securing the OT, Network Level: Potential Security Issues, System Level: Potential Security Issues, Identity Access Management

**UNIT-V:**

**(9 Periods)**

**INTRODUCING INDUSTRY 4.0:** Defining Industry 4.0, Four Main Characteristics of Industry 4.0, The Value Chain, Industry 4.0 Design Principles, Building Blocks of Industry 4.0, Smart Manufacturing.

**SMART FACTORIES:** Introducing the Smart Factory, Smart Factories in Action, Importance of Smart Manufacturing, Real-World Smart Factories - GE's Brilliant Factory, Airbus: Smart Tools and Smart Apps, Siemens' Amberg Electronics Plant (EWA), Industry 4.0: The Way Forward

**Total Periods: 45**

***Topics for self-study are provided in lesson plan***

**TEXT BOOK:**

1. Alasdair Gilchrist, *Industry 4.0: The Industrial Internet of Things*, Apress Publications, 2016.

**REFERENCE BOOKS:**

1. Giacomo Veneri and Antonio Capasso, *Hands-on Industrial Internet of Things: Create a powerful Industrial IoT infrastructure using Industry 4.0*, Ingram Academic Services, 2018.
2. Vijay Madiseti and Arshdeep Bahga, *Internet of Things A Hands-On- Approach*, Orient Blackswan Private Limited, 2015.
3. Francis daCosta, *Rethinking the Internet of Things: A Scalable Approach to Connecting Everything*, 1<sup>st</sup> edition, Apress Publications, 2014.

## IV B. Tech. - I Semester

### (19BM71202)BIG DATA ANALYTICS FOR IoT

Int. Marks	Ext. Marks	Total Marks	L	T	P	C
40	60	100	3	1	-	4

**PRE-REQUISITES:** A course on Internet of Things Lab.

**COURSE DESCRIPTION:** The course provides introduction to IoT Analytics and Big Data Analytics, Sensors And Tools of IoT Analytics, Services of IoT,Big Data Storage Systems for IoT, Case Studies and Applications of IoT

**COURSE OUTCOMES:** *After successful completion of the course, students will be able to:*

CO1.Use Analytical Architecture and its exploration in Data Analytics for IoT

CO2. Analyze and Visualize the Sensor data for IoT.

CO3. Apply Advanced Analytical Architectures as a service for IoT.

CO4. Analyze Big data storage systems in IoT.

CO5. Develop Real Time solutions for given societal problems.

#### DETAILED SYLLABUS:

##### UNIT-I: INTRODUCING IoT ANALYTICS

(9 periods)

**Introduction:**IoT Data and BigData,Challenges of IoT Analytics Applications,IoT Analytics Lifecycle and Techniques.**IoT, Cloud and Big Data Integration for IoT Analytics:**Cloud-based IoT Platform,Data Analytics for the IoT,Data Collection Using Low-power, Long-range Radios,WAZIUP Software Platform, iKaaS Software Platform.

##### UNIT-II: SENSORS AND TOOLS OF IoT ANALYTICS

(9 periods)

**Sensors:** Architecture for Social and Physical Sensors, Local Event Retrieval, Using Sensor Metadata Streams to Identify Topics of Local Events in the City, Venue Recommendation. **Development Tools for IoT Analytics Applications:**VITAL Development Environment,Tools for IoT Semantic Analytics, Development Examples:Predict the Footfall!,Find a Bike!

##### UNIT-III: IoT ANALYTICS AS A SERVICE

(9 periods)

Architecture for IoT Analytics-as-a-Service, Sensing-as-a-Service Infrastructure Anatomy, Scheduling, Metering and Service Delivery, Sensing-as-a-Service Examples, From Sensing-as-a-Service to IoT-Analytics-as-a-Service, Data Collection to Deployment and Operationalization, Ethical IoT.

##### UNIT-IV:BIG DATA STORAGE SYSTEMS AND CASE STUDIES FOR IoT (9 periods)

**Perspectives and Challenges:**Big data analytics for IoT,Data Storage and Access for IoT,Dynamic-Data Handling in Big Data Storage Systems,Heterogeneous Datasets in IoT Big Data,Semantic Analytics for Big Data. **Case Studies:** Data Analytics in Smart Buildings, Internet-of-Things Analytics for Smart Cities.

## **UNIT V – APPLICATIONS OF IoT AND BIG DATA SOLUTIONS (9 Periods)**

**IoTBDs Applications:** Smart Transportation, Smart Healthcare, Smart Grid, Smart Inventory System, Smart Manufacturing, Smart Retail, Smart agriculture, **Big Data Management Solutions for IoT:** Case Study – Connected Car.

**Total Periods: 45**

**Topics for self-study are provided in lesson plan**

### **TEXT BOOKS:**

1. John Soldatos, *Building Blocks for IoT Analytics*, River Publishers, 2017.
2. Pethuru Raj, T. Poongodi, Balamurugan Balusamy, and Manju Khari, *Internet of Things and Big Data Analytics Integrated Platforms and Industry Use Cases*, 1<sup>st</sup> edition, CRC Press, 2020.

### **REFERENCE BOOKS:**

1. Hwaiyu Geng, P.E., *Internet of Things and Data Analytics Handbook*, Wiley Publishing, 2017.
2. Dey. N, Hassanien A.E, Bhatt C, Ashour A.S, Satapathy S.C, *Data Analytics: Internet of Things and Big Data Analytics Toward Next-Generation Intelligence*, Springer, 2018.

### **ADDITIONAL LEARNING RESOURCES:**

1. [https://www.tutorialspoint.com/excel\\_data\\_analysis/data\\_analysis\\_overview.html](https://www.tutorialspoint.com/excel_data_analysis/data_analysis_overview.html)
2. <https://data-flair.training/blogs/data-analytics-tutorial/>
3. <https://pythonprogramming.net/data-analysis-tutorials/>

**IV B. Tech. –I Semester**  
**(19BM71231) ADVANCED IoT LAB**

Int. Marks	Ext. Marks	Total Marks	L	T	P	C
50	50	100	-	-	2	1

**PRE-REQUISITES:** A course on Internet of Things Lab.

**COURSE DESCRIPTION:** Hands-on practice on Internet of Things (IoT); IBM Bluemix; Amazon AWS cloud; Google Firebase; Git hub IoT packages; Python IoT libraries for the development of IoT applications.

**COURSE OUTCOMES:** After successful completion of the course, students will be able to:

- CO1. Demonstrate hands-on experience on IoT.
- CO2. Use IBM Bluemix, Amazon AWS cloud, Google Firebase, Git hub IoT packages and Python libraries for the development of IoT applications.
- CO3. Analyze the user requirements for the development of IoT applications.
- CO4. Develop IoT applications to solve societal problems using cloud environment.
- CO5. Work independently or in teams to solve problems with effective communication.

**LIST OF EXPERIMENTS:**

1. Study of AT89S52 Ultra Development Kit with Development Tool /Environment of Kiel Software for Microcontroller programming
2. Familiarize with Intel Galileo Gen2 board and understand the procedure of creation and compilation of C source code.
3. Study of IoT Data Logging using Beaglebone Black and Thingspeak.
4. Turn your smartphone into an IoT device using the IBM Watson IoT Platform cloud-hosted service.
5. Controlling home light using WiFi Node MCU, and Relay module
6. Develop an application using the Google Firebase NodeMCU ESP8266
  - a) Connecting Arduino Node-MCU with Google Firebase
  - b) Control Led Using Firebase Console
  - c) Control Led with Android App using Firebase database
7. Develop an application using the Google Firebase for controlling LED and Android App with NodeMCU
8. Configuring IOT Based DHT Sensor using AWS
9. Design and develop Alexa based Home Automation System using AWS.

**REFERENCE BOOKS:**

1. Arshdeep Bahga and Vijay Madiseti, *Internet of Things( A hands on approach)*, 1<sup>st</sup> Edition, VPI Publications, 2014.
2. Adrian McEwen and Hakin Cassimally, *Designing the Internet of Things*, Wiley India.
3. Massimo Banzi and Michael Shiloh, *Getting Started with Arduino*, 3<sup>rd</sup> Edition, Maker Media.

**ADDITIONAL LEARNING RESOURCES:**

1. <https://aws.amazon.com/iot-core/getting-started/>
2. <https://www.balena.io/docs/learn/develop/integrations/bluemix/>
3. <https://github.com/thingsboard>
4. <https://www.javatpoint.com/iot-internet-of-things>

## **MINOR DEGREE IN CYBER SECURITY**

**Offering Department:** COMPUTER SCIENCE AND SYSTEMS  
ENGINEERING

**Students of Eligible Branches:** ECE, EEE, EIE, ME and CE

### **COURSE STRUCTURE**

Year & Semester	Course Code	Course Title	Contact Periods per week				C	Scheme of Examination Max. Marks		
			L	T	P	Total		Int. Marks	Ext. Marks	Total Marks
III B.Tech. I-Sem  (2 Theory + 1 Lab)	19BM51501	Computer Networks	3	-	-	3	3	40	60	100
	19BM51502	Adhoc and wireless Sensor Networks	3	-	-	3	3	40	60	100
	19BM51503	Operating Systems	3	-	-	3	3	40	60	100
	19BM51531	Computer Networks Lab	-	-	2	2	1	50	50	100
III B.Tech. II-Sem  (2 Theory + 1 Lab)	19BM61501	Cloud Computing	3	-	-	3	3	40	60	100
	19BM61502	Modern Cryptography	3	-	-	3	3	40	60	100
	19BM61503	Cyber security	3	-	-	3	3	40	60	100
	19BM61531	Modern Cryptography Lab	-	-	2	2	1	50	50	100
IV B.Tech. I-Sem  (1 Theory + 1 Lab)	19BM71501	IoT Security	3	-	-	3	3	40	60	100
	19BM71502	Information Security	3	-	-	3	3	40	60	100
	19BM71531	Information Security Lab	-	-	2	2	1	50	50	100

**Note:** If any student has chosen a course from the above list in their regular curriculum then, he/she is not eligible to opt the same course/s for the Minor degree. It is the responsibility of the student to acquire/complete prerequisite before taking the respective course.

### III B. Tech. - I Semester

#### (19BM51501) COMPUTER NETWORKS

Int. Marks	Ext. Marks	Total Marks	L	T	P	C
40	60	100	3	-	-	3

#### PRE-REQUISITES: -

**COURSE DESCRIPTION:** Introduction to computer networks; Protocols of physical layer, data link layer, medium access control sub layer, network layer, transport layer, application layer.

**COURSE OUTCOMES:** After successful completion of the course, students will be able to:

- CO1. Analyze the types of network topologies, layers and protocols.
- CO2. Evaluate subnetting and routing algorithms for finding optimal paths in networks.
- CO3. Solve problems related to flow control, error control and congestion control in data transmission.
- CO4. Assess the impact of wired and wireless networks in the context of network protocols Like DNS, SMTP, HTTP, and FTP.
- CO5. Apply ethical principles and standards for developing network-based solutions.

#### DETAILED SYLLABUS:

##### UNIT- I: INTRODUCTION AND PHYSICAL LAYER (9 Periods)

Network hardware, Network software, Reference models - OSI, TCP/IP; Example networks - Internet; Wireless LANs - 802.11.

**Physical Layer** - Guided transmission media, Wireless transmission, Switching - Circuit switching, Packet switching.

##### UNIT- II: DATA LINK LAYER AND MEDIUM ACCESS CONTROL SUBLAYER (9 Periods)

**Data Link Layer:** Data link layer design issues, Error detection and correction - CRC, Hamming codes; Elementary data link protocols, Sliding window protocols.

**Medium Access Control Sub layer:** ALOHA, Carrier sense multiple access protocols, Collision free protocols, Ethernet, Data link layer switching - Repeaters, Hubs, Bridges, Switches, Routers, Gateways.

##### UNIT- III: NETWORK LAYER (9 Periods)

Network layer design issues, Routing algorithms - Shortest path algorithm, Flooding, Distance vector routing, Link state routing, Hierarchical routing, Broadcast routing, Multicast routing, Anycast routing; Congestion control algorithms, Network layer in the internet - The IP version 4 protocol, IP addresses, IP version 6, Internet control protocols, OSPF, BGP.

##### UNIT- IV: TRANSPORT LAYER (9 Periods)

UDP - Segment header, Remote procedure call, Real-time transport protocols; TCP - service model, Protocol, Segment header, Connection establishment, Connection release, Sliding window, Timer management, Congestion control.

##### UNIT- V: APPLICATION LAYER (9 Periods)

Domain Name System (DNS) - Name space, Domain resource records, Name servers; Electronic mail - Architecture and services, User agent, Message formats, Message transfer, Final delivery; The World Wide Web - Architectural overview, HTTP, FTP.

**Total Periods: 45**



***Topics for self-study are provided in the lesson plan***

**TEXT BOOK(S):**

1. Andrew S. Tanenbaum and David J. Wetherall, *Computer Networks*, Pearson, 5<sup>th</sup> Edition, 2015.

**REFERENCE BOOKS:**

1. Behrouz A. Forouzan, *Data Communications and Networking*, McGraw Hill, 5<sup>th</sup> Edition, 2013.
2. James F. Kurose and Keith W. Ross, *Computer Networking: A Top-Down Approach*, Pearson, 7<sup>th</sup> Edition, 2017.

**ADDITIONAL LEARNING RESOURCES:**

- <https://www.cisco.com/c/en/us/solutions/small-business/resourcecenter/networking/networking-basics.html>
- <https://memberfiles.freewebs.com/00/88/103568800/documents/Data.And.Computer.Communications.8e.WilliamStallings.pdf>

### III B. Tech. – I Semester

#### (19BM51502) AD HOC AND WIRELESS SENSOR NETWORKS

Int. Marks	Ext. Marks	Total Marks	L	T	P	C
40	60	100	3	-	-	3

#### PRE-REQUISITES: -

**COURSE DESCRIPTION:** Ad hoc Wireless Networks, Medium Access Control Protocols for Ad hoc Wireless Networks, Routing Protocols for Ad hoc Wireless Networks, Wireless Sensor Networks, Medium Access Control Protocols for WSN's.

**COURSE OUTCOMES:** *After successful completion of the course, students will be able to:*

- CO1. Investigate ad hoc and wireless sensor networks to improve the network performance.
- CO2. Analyze the issues in MAC, routing protocols in Ad hoc wireless networks.
- CO3. Apply routing protocols of MAC Layer in sensor networks to provide networking solutions.
- CO4. Follow norms and standards in engineering practice to solve ad hoc and wireless sensor network problems.

#### DETAILED SYLLABUS:

##### UNIT-I: AD HOC WIRELESS NETWORKS (8 periods)

Fundamentals of wireless communication technology, the electromagnetic spectrum, Radio propagation mechanisms, Characteristics of the wireless channel, Applications, Issues, Ad hoc wireless Internet.

##### UNIT-II: MAC PROTOCOLS FOR AD HOC WIRELESS NETWORKS (8 periods)

Issues in designing a MAC protocol, Classification of MAC protocols, Contention based protocols, Contention based protocols with reservation mechanisms, and Contention based protocols with scheduling mechanisms.

##### UNIT-III: ROUTING PROTOCOLS FOR AD HOC WIRELESS NETWORKS (9 periods)

Issues in designing routing and transport layer protocol for Ad hoc networks, Classification of routing protocols, Table driven routing protocols, On demand routing protocols, Hybrid routing protocols.

##### UNIT-IV: WIRELESS SENSOR NETWORKS (9 periods)

Vision of ambient intelligence, Application examples, Types of applications, Challenges of WSN's, Why are sensor networks different, Enabling technologies, Hardware components, Energy consumption of sensor nodes.

##### UNIT-V: MEDIUM ACCESS CONTROL PROTOCOLS FOR WIRELESS SENSOR NETWORKS (11 periods)

Fundamentals of MAC protocols, Low duty cycle protocols and wake up concepts, Contention based protocols, Schedule based protocols, IEEE 802.15.4 MAC protocol, 802.11 and Bluetooth, Case study on tele healthcare – Introduction, MASN hardware design, Reliable MASN communication protocols, MASN software design, Integration of RFID and wearable sensors.

**Total Periods: 45**

**Topics for self-study are provided in lesson plan**

**TEXT BOOKS:**

1. C. Siva Ram Murthy, B.S. Manoj, *Ad Hoc Wireless Networks: Architectures and Protocols*, Pearson, 2012.
2. Holger Karl and Andreas Willig, *Protocols and Architectures for Wireless Sensor Networks*, Wiley, 2017.

**REFERENCE BOOKS:**

1. Fei Hu and Xiaojun Cao, *Wireless Sensor Networks: Principles and Practice*, CRC Press, 2010.
2. Yi Qian, Peter Muller and Hsiao-Hwa Chen, *Security in Wireless Networks and Systems*, Wiley, 2011.

**ADDITIONAL LEARNING RESOURCES:**

- <https://www.tyndall.ie/wireless-sensor-networks-2>
- <https://www.elprocus.com/introduction-to-wireless-sensor-networks-types-and-applications/>
- <https://www.analog.com/en/design-center/landing-pages/002/apm/wsn-solution-2014.html>

## II B. Tech. – I Semester

### (19BM51503) OPERATING SYSTEMS

Int. Marks	Ext. Marks	Total Marks	L	T	P	C
40	60	100	3	-	-	3

#### PRE-REQUISITES: -

**COURSE DESCRIPTION:** Operating Systems Operations; Process Scheduling; Process Synchronization, Deadlocks; Paging and Segmentation, Disk Scheduling; File Concepts, I/O Interface; Concepts of Protection and Security.

#### COURSE OUTCOMES:

*On successful completion of this course, the students will be able to:*

- CO1. Analyze performance of CPU scheduling algorithms.
- CO2. Design solutions for process synchronization problems by using semaphores and monitors.
- CO3. Devise solutions for deadlocks using deadlock handling mechanisms.
- CO4. Solve memory management problems using page replacement and disk scheduling algorithms.
- CO5. Identify efficient file allocation methods for optimal disk utilization.
- CO6. Analyze services of I/O subsystems and mechanisms of security & protection.

#### DETAILED SYLLABUS:

#### UNIT I: INTRODUCTION TO OPERATING SYSTEM AND PROCESS MANAGEMENT (8 periods)

**INTRODUCTION:** Definition, Operating System Structure and Services, System Calls.

**PROCESS MANAGEMENT:** Process Scheduling, Process Control Block, Inter Process Communication, Threads, Multithreading Models, CPU Scheduling Criteria, Scheduling Algorithms, Multiprocessor Scheduling.

#### UNIT II: PROCESS SYNCHRONIZATION AND DEADLOCKS (10 periods)

**PROCESS SYNCHRONIZATION:** Critical Section Problem, Peterson's Solution, Synchronization Hardware, Semaphores, Synchronization Problems, Monitors.

**DEADLOCKS:** System Model, Deadlock characterization, Methods for handling deadlocks, Prevention, Detection, Avoidance, Recovery from deadlock.

#### UNIT III: MEMORY MANAGEMENT AND SECONDARY STORAGE (10 periods)

**MEMORY MANAGEMENT:** Swapping, Contiguous Allocation, Paging, Segmentation, Segmentation with Paging.

**VIRTUAL MEMORY:** Demand Paging, Page Replacement Algorithms, Copy-on-Write, Thrashing.

**SECONDARY STORAGE STRUCTURE:** Overview of Mass Storage Structure, Disk Structure, Disk Scheduling, Disk Management.

#### UNIT IV: File and I/O Systems (8 periods)

**FILE SYSTEM:** File concept, Access Methods, Directory Structure, File System Structure, i-node, File System Implementation, Directory Implementation, Allocation Methods.

**I/O SYSTEM:** I/O Hardware, Application I/O Interface, Kernel I/O subsystem

## **UNIT V – PROTECTION AND SECURITY**

**(9 periods)**

**PROTECTION:** Goals, Principles, Domain of Protection, Access Matrix, Implementation of Access Matrix, Access Control, Revocation of Access Rights.

**SECURITY:** Security Problem, Program Threats, System and Network Threats, User Authentication, Implementing Security Defenses, Firewalling to Protect Systems and Networks, Computer-Security Classifications.

**Total Periods: 45**

***Topics for Self Study are provided in Lesson Plan***

### **TEXT BOOKS:**

1. Abraham Silberschatz, Peter Baer Galvin and Greg Gagne, *Operating System Concepts*, Wiley India Edition, 9<sup>th</sup> Edition, 2016.

### **REFERENCE BOOKS:**

1. William Stallings, *Operating Systems, Internals and Design Principles*, Pearson Education, 7<sup>th</sup> Edition, 2013.

2. Andrew S. Tanenbaum, *Modern Operating Systems*, PHI, 3<sup>rd</sup> Edition, 2009.

### III B. Tech. - I Semester

#### (19BM51531) COMPUTER NETWORKS LAB

Int. Marks	Ext. Marks	Total Marks	L	T	P	C
50	50	100	-	-	2	1

**PRE-REQUISITES:** Course on Computer Networks.

**COURSE DESCRIPTION:** Hands on practice with NS3; Packet Tracer network simulation tools; Simulation of network topologies; ARP protocol; CSMA/CD protocol; Distance Vector/Link State Routing protocols; Transmission errors; Sliding window protocol; TCP; UDP.

**COURSE OUTCOMES:** After successful completion of the course, students will be able to:

- CO1. Apply mathematical foundations to solve computational problems in computer networks.
- CO2. Select and apply network simulation tools like NS3, Packet Tracer to simulate networking protocols.
- CO3. Simulate and analyze network topologies, network protocols to provide efficient networking solutions.
- CO4. Work independently and communicate effectively in oral and written forms.

#### **LIST OF EXERCISES:**

1. a) Study of network devices and network IP in detail.  
b) Simulate a peer to peer topology of a computer network.  
c) Simulate IPv4 addressing in a computer network (give IP Address of different classes in given Network id).

#### Exercises on Packet Tracer Simulator Tool:

2. Introduction to Packet Tracer
3. a) Study of basic network commands and network configuration commands.  
i) ping ii) nslookup iii) netstat iv) ifconfig  
b) Create a network topology and configure a network topology with four PCs, two switches, and two routers.

#### Exercises on NS3 Simulator Tool:

4. a) Introduction to NS3 tool.  
b) Create a network with three nodes namely 0, 1 and 2. Establish a TCP connection between node 0 and node 2 such that node 0 will send TCP packets to node 2 via node 1.
5. a) Create a simple topology of two nodes (Node1, Node2) separated by a point-to-point link. Setup a UDP Client on one Node1 and a UDP Server on Node2. Consider a fixed data rate Rate1.  
i) Measure end to end throughput whilst varying the latency of the link.  
ii) Add another client application to Node1 and a server instance to Node2. What do you need to configure to ensure that there is no conflict?  
iii) Repeat step 3 with the extra client and server application instances. Show screenshots of pcap traces which indicate that delivery is made to the appropriate server instance.  
b) Simulate a Local Area Network. Consider a local area network formed by nodes 3, 4, and 5. This LAN communicates with the external world through a router denoted by node 2. There are two servers connected to the router and

represented by nodes 0 and 1. Node 0 is running an application over TCP, which is accessed by node 4. Node 1 is running an application on UDP, which is accessed by node 5. Analyze the trace file.

6. Simulate link errors. Presence of link errors cause one or more packets to be retransmitted. Consider the following topology.

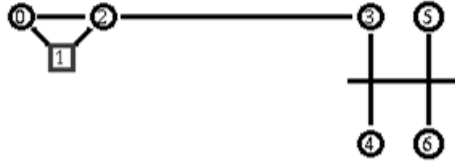

Node #2 act as a router. Any traffic to or from the LAN passes through it. Consider node #1 running a FTP server, and node #5 is downloading a file of size 4 MB. However, the link between node #2 and #3 is fault. It drops packets with a fixed probability of 0.2. Implement a link error model to reflect this. Try different values of the simulation time to ensure that the file has been entirely transferred. Has the plot of bytes received a linear curve or non-linear? Why?

7. Simulate Address Resolution Protocol (ARP) to associate a logical address with a physical address and Reverse Address Resolution Protocol (RARP) allows a host to discover its Internet address when it knows only its physical address.
8. Simulate packet transmission over a CSMA/CD based LAN with NS3. Consider the LAN with seven nodes to be an isolated one i.e. not connected to the Internet. Node #0 in the LAN acts as a UDP traffic source, and node #6 is the destination node. Assume CBR traffic to be flowing between the nodes. The simulation lasts for 25 seconds. In Ethernet a packet is broadcasted in the shared medium, and only the destination node accepts the packet. Other nodes simply drop it. What should be the number of hops a packet from node #0 to node # 6 travel? Verify this from the "Hop Count" plot.
9. a) UDP uses a simple connectionless communication model with a minimum of protocol mechanism. The implementation provides checksums for data integrity, and port numbers for addressing different functions at the source and destination of the datagram. Simulate half duplex chat User Datagram Protocol.
  - b) TCP model supports a full bidirectional TCP with connection setup and close logic. Simulate full duplex chat Transmission Control Protocol.
- 10 a) In a typical FTP session, the user is sitting in front of one host (the local host) and wants to transfer files to or from a remote host. Implement File Transfer Protocol to move files between local and remote file systems.
  - b) Sliding window protocol supports reliable and efficient transmission between nodes and it also obtains higher throughput than that of stop-n-wait protocol. Simulate sliding window protocol normal operation and timeout operations.
- 11 Configure the following network to find shortest path between R2 LAN to R3 LAN using Distance Vector / Link State Routing Protocol.

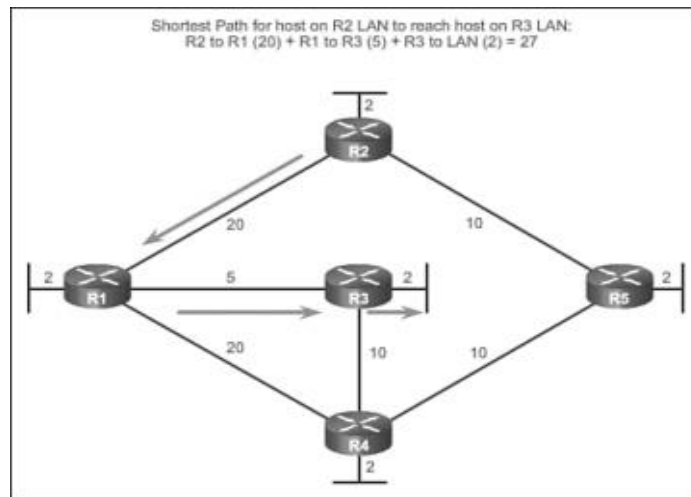

### REFERENCE BOOKS:

1. Andrew S. Tanenbaum and David J. Wetherall, *Computer Networks*, Pearson, 5<sup>th</sup> Edition, 2015.
2. A. Jesin, *Packet Tracer Network Simulator*, Packt Publishing, 2014.
3. Jack L. Burbank, *An Introduction to Network Simulator 3*, Wiley, 2018.

### Software/Tools used:

- Network simulator tools - NS3, Packet Tracer
- Virtual Labs (Computer Networks Lab - [http://vlabs.iitb.ac.in/vlabs-dev/labs\\_local/computer-networks/labs/explist.php](http://vlabs.iitb.ac.in/vlabs-dev/labs_local/computer-networks/labs/explist.php))
- Virtual Labs (Advanced Network Technologies Virtual Lab - <http://vlabs.iitkgp.ernet.in/ant>)



### III B. Tech. – II Semester

#### (19BM61501) CLOUD COMPUTING

Int. Marks	Ext. Marks	Total Marks	L	T	P	C
40	60	100	3	-	-	3

#### PRE-REQUISITES: -

**COURSE DESCRIPTION:** Fundamental Cloud Computing and Virtualization; Understanding Cloud Models and Architectures; Understanding Cloud Services, Applications and Capacity Planning; Exploring Platform as a Service (PaaS); Exploring Infrastructure as a Service (IaaS).

**COURSE OUTCOMES:** After successful completion of the course, students will be able to:

- CO1. Demonstrate knowledge on basic concepts and terminologies of Cloud Computing and Virtualization.
- CO2. Select appropriate Cloud deployment models, Service models and Architectures in Cloud Application development.
- CO3. Analyze Cloud services, Applications and Capacity Planning.
- CO4. Apply different PaaS application frameworks to construct Cloud applications.
- CO5. Develop web applications through Google, Microsoft and Amazon web services as per societal needs.

#### DETAILED SYLLABUS:

##### UNIT I–FUNDAMENTAL CLOUD COMPUTING AND VIRTUALIZATION (10 periods)

**Cloud Computing:** Origin and influences, Basic concepts and terminology, Goals and benefits, Risks and challenges, Roles and boundaries and Cloud characteristics.

**Introduction to Virtualization:** Characteristics, Taxonomy of virtualization technologies, Pros and cons of virtualization, Virtualization Technologies: Xen, VMware and Hyper-V.

##### UNIT II– UNDERSTANDING CLOUD MODELS AND ARCHITECTURES (8 periods)

**Cloud Models:** NIST model, Cloud Cube model, Deployment models: Public, Private, Hybrid and Community; Service models: IaaS, PaaS and SaaS.

**Understanding Cloud Architecture:** Exploring the Cloud Computing Stack: Composability, Infrastructure, Platforms, Virtual Appliances, Communication Protocols, Applications; Connecting to the Cloud: The Jolicloud Netbook OS and Chromium OS - The Browser as an Operating System.

##### UNIT III – UNDERSTANDING CLOUD SERVICES, APPLICATIONS AND CAPACITY PLANNING (9 periods)

**Understanding Cloud Services and Applications** Infrastructure as a Service (IaaS): IaaS workloads, Pods, aggregation, and silos; Platform as a Service (PaaS), Software as a Service (SaaS): SaaS characteristics, Open SaaS and SOA, Salesforce.com and CRM SaaS; Identity as a Service (IDaaS): Identity, Networked identity service classes, Identity system codes of conduct, IDaaS interoperability; Compliance as a Service (CaaS).

**Capacity Planning:** Defining Baseline and Metrics: Baseline measurements, System metrics, Load Testing, Resource ceilings, Server and instance types; Network Capacity and Scaling.

#### **UNIT IV – EXPLORING PLATFORM AS A SERVICE (PaaS) (10 periods)**

**PaaS Application Frameworks:** Drupal, Eccentex AppBase 3.0, Long Jump, Square space, WaveMaker and Wolf Frameworks.

**Exploring Platform as a Service using Google Web Services:** Surveying the Google Application Portfolio, Google Toolkit and Working with the Google App Engine.

**Exploring Platform as a Service using Microsoft Cloud Services:** Exploring Microsoft Cloud Services, Defining the Windows Azure Platform, Windows Live: Windows Live Essentials, Windows Live Home and Windows Live for Mobile.

#### **UNIT V – EXPLORING INFRASTRUCTURE AS A SERVICE (IaaS) (8 periods)**

Understanding Amazon Web Services, Amazon Web Service Components and Services, Working with the Elastic Compute Cloud (EC2): Amazon Machine Images, Pricing models, System images and software, Creating an account and instance on EC2; Working with Amazon Storage Systems: Amazon Simple Storage System (S3), Amazon Elastic Block Store (EBS) and CloudFront; Understanding Amazon Database Services: Amazon SimpleDB, Amazon Relational Database Service (RDS) and Choosing a database for AWS.

**Total Periods: 45**

**Topics for Self-study are provided in the Lesson Plan.**

#### **TEXT BOOKS:**

1. Barrie Sosinsky, *Cloud Computing Bible*, Wiley India Pvt Ltd, 2011 (Reprint 2017).
2. Thomas Erl and RicardoPuttini, *Cloud Computing- Concepts, Technology and Architecture*, Pearson, 2014 (Seventh Impression 2017).

#### **REFERENCE BOOKS:**

1. Rajkumar Buyya, Christian Vecchiloa and S Thamarai Selvi, *Mastering Cloud Computing*, McGraw Hill Education, 2013 (Reprint 2017).
2. George Reese, *Cloud Application and Architectures*, O'Reilly, 2009 (Reprint 2017).

#### **ADDITIONAL LEARNING RESOURCES:**

1. "Exploring the Google Toolkit", <https://code.google.com/>, drafted on 23 December, 2019.
2. "Understanding Amazon Web Services", <https://aws.amazon.com/>, drafted on 23 December, 2019.
3. "Exploring Microsoft Cloud Services", <https://www.microsoft.com/windowsazure>, drafted on 23 December, 2019.

### III B. TECH. - II SEMESTER

#### (19BM61502) MODERN CRYPTOGRAPHY

Int. Marks	Ext. Marks	Total Marks	L	T	P	C
40	60	100	3	-	-	3

#### PRE-REQUISITES: -

**COURSE DESCRIPTION:** Cryptographic protocols; Encryption techniques for confidentiality; Mathematics of symmetric and asymmetric algorithms; Hash functions for integrity; digital signature schemes.

**COURSE OUTCOMES:** After successful completion of the course, students will be able to:

- CO1. Apply cryptographic protocols to ensure authentication in network systems.
- CO2. Analyze the efficiency of cryptographic techniques based on security attacks.
- CO3. Choose suitable key management scheme for efficient key exchange between the authenticated parties.
- CO4. Implement algorithms using information, complexity, and number theories for ensuring the security requirements-CIA.
- CO5. Evaluate Message Digest and Secure Hash Algorithms using hash functions for data Integrity.
- CO6. Analyze well known digital signature algorithms for securing communication.

#### DETAILED SYLLABUS:

##### UNIT I – FOUNDATIONS OF CRYPTOGRAPHY (8 Periods)

**FOUNDATIONS OF CRYPTOGRAPHY:** Steganography, Substitution ciphers and Transposition Ciphers, One Time Pads. **Protocol Building Blocks:** Introduction to protocols, communications using symmetric Cryptography, One-Way Hash Functions, Communications Using Public-Key Cryptography, Digital Signatures with Encryption, Random and Pseudo-Random-Sequence Generation, **Basic Protocols:** Key Exchange, Authentication and key Exchange.

##### UNIT II- CRYPTOGRAPHIC TECHNIQUES (8 Periods)

**CRYPTOGRAPHIC TECHNIQUES:** Key Management, Electronic Codebook Mode, Block Replay, Cipher Block Chaining Mode, Stream Ciphers, Self-Synchronizing Stream Ciphers, Cipher-Feedback Mode, Synchronous Stream Ciphers, Output-Feedback Mode, Counter Mode, Choosing a Cipher Mode, Interleaving, Block Ciphers versus Stream Ciphers.

##### UNIT III- MATHEMATICS FOR CRYPTOGRAPHIC ALGORITHMS (12 Periods)

**MATHEMATICS FOR CRYPTOGRAPHIC ALGORITHMS:** Mathematical background: Information Theory, Complexity Theory, Number Theory, Factoring, Prime Number Generation, Discrete Logarithms in a Finite Field, Data **Encryption** Standard (DES), DES decryption, Security of DES, DES variants, Public Key Algorithms: RSA, Pholig-Hellman, RABIN, Elliptic Curve Cryptosystems.

##### UNIT IV- HASH FUNCTIONS (8 Periods)

**HASH FUNCTIONS:** One Way Hash Functions, Snefru hash function, N- Hash, MD4, MD5, Secure Hash Algorithm (SHA), Security of SHA, One Way Hash Functions Using

Symmetric Block Algorithms, Using Public-Key Algorithms, Message Authentication Codes (MAC).

## **UNIT V- DIGITAL SIGNATURES**

**(9 Periods)**

**DIGITAL SIGNATURES:**Digital Signature Algorithm (DSA), Security of DSA, Discrete Logarithm Signature Schemes, Ongchnorr-Shamir, SCHNORR authentication and signature scheme, Diffie-Hellman Key exchange, Station-to-Station Protocol, Shamir's Three-Pass Protocol.

**Total Periods 45**

***Topics for self-study are provided in lesson plan***

### **TEXTBOOKS:**

1. Bruce Schneier, "Applied Cryptography: Protocols, Algorithms and Source Code in C", John Wiley and Sons, New York, 2009.

### **REFERENCE BOOKS:**

1. Alfred J Menezes, Paul C van Oorschot and Scott A.Vanstone, "Handbook of Applied Cryptography", CRC Press, New York, 2010.
2. Wenbo Mao, "Modern Cryptography Theory and Practice", Pearson Education, 2004

### **ADDITIONAL LEARNING RESOURCES:**

<https://www.coursera.org/specializations/applied-crypto>  
<https://www.udacity.com/course/applied-cryptography--cs387>  
<https://www.classcentral.com/course/udacity-applied-cryptography-326>  
<https://www.classcentral.com/course/udacity-applied-cryptography-326>  
[https://wiki.openssl.org/index.php/Command\\_Line\\_Uilities](https://wiki.openssl.org/index.php/Command_Line_Uilities)  
<https://www.sslshopper.com/article-most-common-openssl-commands.html>

### III B. Tech.–II Semester

#### (19BM61503) CYBER SECURITY

Int. Marks	Ext. Marks	Total Marks	L	T	P	C
40	60	100	3	-	-	3

#### PRE-REQUISITES: -

**COURSE DESCRIPTION:** Cybercrime, Cyberoffenses, Phishing, Identity theft, Cybercrime in mobile and wireless devices, Organizational measures for handling mobile devices, Security implications on using mobile devices, Tools and methods used in cybercrime, Forensics of computer and handheld devices, Real-life examples of cybercrime.

**COURSE OUTCOMES:** After successful completion of the course, students will be able to:

- CO1. Analyze methods of cybercrime, cyberoffenses to maintain cybersecurity.
- CO2. Investigate tools used for cybercrime to protect computational assets.
- CO3. Apply appropriate authentication mechanisms to reduce attacks on mobile and wireless devices.
- CO4. Use appropriate cyberforensics tools and techniques to maintain cybersecurity.
- CO5. Recognize the need for cybersecurity and practice ethics to protect privacy, property rights in cyberspace.

#### DETAILED SYLLABUS:

##### UNIT-I: CYBERCRIME (8 periods)

Cybercrime and information security, Cybercriminals, Classifications of cybercrimes, Need for Cyberlaws in Indian context, Legal perspectives of cybercrime, Indian perspective of cybercrimes, Cybercrime and the Indian ITA 2000, Positive aspects and weak areas of ITA 2000, Amendments made in Indian ITA 2000 for admissibility of e-records, Amendments to the Indian IT Act, Global perspective on cybercrimes, Intellectual property in cyberspace, Ethical dimension of cybercrimes.

##### UNIT-II: CYBEROFFENSES (11 periods)

Categories of cybercrime, How criminals plan the attacks, Social engineering, Cyberstalking, Cybercafe and cybercrimes, Botnets, Attack vector, Cloud computing, Phishing – Methods, Techniques, Spear phishing, Phishing scams, Phishing toolkits, Spy phishing, Countermeasures; Identity Theft – Personally identifiable information, Types, Techniques, Countermeasures, Effacing online identity.

##### UNIT-III: CYBERCRIME IN MOBILE AND WIRELESS DEVICES (7 periods)

Proliferation of mobile and wireless devices, Trends in mobility, Credit card frauds in mobile and wireless computing era, Security challenges posed by mobile devices, Registry settings for mobile devices, Authentication service security, Attacks on mobile/cell phones, Security implications of mobile devices for organizations, Organizational measures for handling mobile devices related security issues.

##### UNIT-IV: TOOLS AND METHODS USED IN CYBERCRIME (10 periods)

Proxy servers and anonymizers, Password cracking, Keyloggers and spywares, Virus and worms, Trojan horses and backdoors, Steganography, DoS and DDoS attacks, SQL Injection, Buffer Overflow, Attacks on wireless networks.

##### UNIT-V: CYBERFORENSICS, CYBERCRIME IN REAL-WORLD (9 periods)

**Forensics of Computer and Handheld Devices:** Cyberforensics, Cyberforensics and digital evidence, Forensics analysis of e-mail, Forensics and social networking sites,

Forensics of handheld devices – Smartphone forensics, EnCase, Device Seizure, MOBILedit.

**Cybercrime examples, mini-cases, online scams:** Real-life examples - Official website of Maharashtra Government hacked, Indian banks lose millions of rupees, Game source code stolen; Mini-cases - Indian Case of online gambling, Indian case of intellectual property crime; Online scams - Cheque cashing scam, Charity scams.

**Total Periods: 45**

**Topics for self-study are provided in lesson plan**

**TEXT BOOK:**

1. Nina Godbole, SunitBelapure, *Cyber Security: Understanding Cyber Crimes, Computer Forensics and Legal Perspectives*, Wiley, 2013.

**REFERENCE BOOKS:**

1. Nilakshi Jain, Ramesh Menon, *Cyber Security and Cyber Laws*, Wiley, 2020.
2. Charles J. Brooks, Christopher Grow, Philip Craig, Donald Short, *Cybersecurity Essentials*, 1<sup>st</sup> Edition, Sybex, 2018.
3. ErdalOzkaya, *Cybersecurity: The Beginner's Guide*, 1<sup>st</sup> Edition, Packt Publishing, 2019.

**ADDITIONAL LEARNING RESOURCES:**

- Yuri Diogenes, ErdalOzkaya, *Cybersecurity: Attack and Defense Strategies*, 2<sup>nd</sup> Edition, Packt Publishing, 2019.
- <http://www.ignou.ac.in/upload/Announcement/programmedetails.pdf>
- Alessandro Parisi, *Hands-On Artificial Intelligence for Cybersecurity*, Packt Publishing, 2019.

### III B. Tech. - II Semester

#### (19BM61531) MODERN CRYPTOGRAPHY LAB

Int. Marks	Ext. Marks	Total Marks	L	T	P	C
50	50	100	-	-	2	1

**PRE-REQUISITES:** Course on Modern Cryptography

**COURSE DESCRIPTION:**

Mono-alphabetic Ciphers; Poly-alphabetic Ciphers; Block modes; Block ciphers; Public Key Algorithms, Message Digest Algorithms, Diffie-Hellman Key Exchange; SHA; Digital Signature Standards.

**COURSE OUTCOMES:**

*After successful completion of the course, students will be able to:*

- CO1 Analyze attack resiliency of classical encryption algorithms to provide security.
- CO2 Develop block cipher modes of operations and stream ciphers to achieve confidentiality in network systems.
- CO3 Analyze the strength of RSA using cryptanalysis.
- CO4 Use Key Exchange algorithm to ensure security primitives.
- CO5 Implement different Message digest algorithms and DSS to achieve authentication.
- CO6 Work independently or communicate effectively in oral and written forms.

**LIST OF PROGRAMMING EXERCISES:**

1. Implement the following monoalphabetic Ciphers and analyze its attack resiliency.
  - a. Shift Cipher
  - b. Affine cipher
2. Implement the following Poly-alphabetic Ciphers and analyze its attack resiliency.
  - a. Hill cipher
  - b. Vigenere
3. Implement the following block cipher modes and analyze the role of Initialization Vector (IV)
  - a. counter mode
  - b. Output Feedback mode
4. Write a program to implement the Data Encryption Standard (DES).
5. Implement a stream cipher algorithm with running key generator.
6. Write a program to Implement RSA algorithm.
7. Write a program to find prime factors of a given large number and analyze the time complexity.
8. Write a program to determine the message digest of a given message using the SHA-1 algorithm.
9. Write a program to implement Diffie-Hellman Key Exchange mechanism.
10. Write a program to implement Digital Signature Standard.

**REFERENCE BOOKS:**

1. William Stallings, *Cryptography and Network Security: Principles and Practice*, Pearson Education, 7<sup>th</sup> Edition, 2017.
2. Douglas R. Stinson, *Cryptography: Theory and Practice*, CRC Press, 3<sup>rd</sup> Edition, 2005.

**ADDITIONAL LEARNING RESOURCES:**

<https://www.classcentral.com/course/udacity-applied-cryptography-326>

<https://www.classcentral.com/course/udacity-applied-cryptography-326>

[https://wiki.openssl.org/index.php/Command\\_Line\\_Uutilities](https://wiki.openssl.org/index.php/Command_Line_Uutilities)

<https://www.sslshopper.com/article-most-common-openssl-commands.html>



**IV B. Tech. – I Semester**  
**(19BM71501) IoT SECURITY**

Int. Marks	Ext. Marks	Total Marks	L	T	P	C
40	60	100	3	-	-	3

**PRE-REQUISITES: -**

**COURSE DESCRIPTION:** Securing the Internet of Things; Cryptographic Fundamentals for IoT; Identity & Access Management Solutions for IoT; Mitigating IoT Privacy Concerns; Cloud Security for IoT

**COURSE OUTCOMES:** After successful completion of this course, the students will be able to:

CO1: Analyze Attacks, threats and vulnerabilities to secure IoT devices.

CO2: Design IoT messaging and communication protocols using Cryptographic primitives

CO3: Apply authentication credentials and Identity Access Management infrastructure to manage IoT

CO4: Analyze privacy concerns in IoT devices by using PIA

CO5: Examine IoT threats in the cloud for effective utilization of cloud services

CO6: Analyze different cloud service providers to IoT computing

**DETAILED SYLLABUS:**

**UNIT I– Securing the Internet of Things (9periods)**

Security Requirements in IoT Architecture - Security in Enabling Technologies -Security Concerns in IoT Applications. Security Architecture in the Internet of Things -Security Requirements in IoT - Insufficient Authentication/Authorization – Insecure Access Control - Threats to Access Control, Privacy, and Availability - Attacks Specific to IoT. Vulnerabilities – Secrecy and Secret-Key Capacity -Authentication/Authorization for Smart Devices - Transport Encryption – Attack & Fault trees

**UNIT II –Cryptographic Fundamentals for IoT (9periods)**

Cryptographic primitives and its role in IoT – Encryption and Decryption – Hashes – Digital Signatures – Random number generation – Cipher suites – key management fundamentals – cryptographic controls built into IoT messaging and communication protocols – Zigbee, Bluetooth-LE, Near Field Communication (NFC).

**UNIT III – Identity & Access Management Solutions for IoT (9periods)**

Identity lifecycle – authentication credentials– passwords, Symmetric keys, certificates, Biometrics, IoTIAMinfrastructure Authorization and Access controls within publish/Subscribe protocols, access controls within communication protocols

**UNIT IV – Mitigating IoT Privacy Concerns (9periods)**

Privacy challenges introduced by IoT- A complex sharing environment- wearable’s, smart homes, Guiding to perform an IoT PIA-Authorities, characterizing collected information, use of collected information, Security, Notice, Data retention Information sharing, redress, auditing and accountability

**UNIT V –Cloud Security for IoT (9periods)**

Cloud services and IoT – offerings related to IoT from cloud service providers – Cloud IoT security controls – An enterprise IoT cloud security architecture – New directions in cloud enabled IoT computing

**Total Periods: 45**

**Topics for self-study are provided in lesson plan**

**TEXT BOOK:**

1. Practical Internet of Things Security: Design a security framework for an Internet connected ecosystem, Brian Russell and Drew Van Duren, 2<sup>nd</sup> Edition 2016.

**REFERENCE BOOKS:**

1. Security and Privacy in Internet of Things (IoTs): Models, Algorithms, and Implementations, Fei Hu, CRC Press 2016.
2. Securing the Internet of Things Elsevier

## IV B. TECH. – I Semester

### (19BM71502) INFORMATION SECURITY

Int.	Ext.	Total Marks	L	T	P	C
40	60	100	3	-	-	3

**PRE-REQUISITES:** -

#### **COURSE DESCRIPTION:**

Computer security; Need of Security; Access Control; Security policies; Software vulnerabilities; Secure Electronic transactions; Secure socket layer; transport layer security; Privacy.

**COURSE OUTCOMES:** After successful completion of this course, the students will be able to:

**CO1:** Apply the security requirements like confidentiality, integrity, and availability to secure network assets from threats and attacks.

**CO2:** Analyze virus, malicious software and worms for detecting distributed Denial of service attacks.

**CO3:** Apply handshaking, alert and change cipher spec protocols and Coding function to secure SSL and TLS.

**CO4:** Apply PGP model and canonical forms to secure E-Mail data at transport layer.

**CO5:** Design firewall to secure the system by applying various intrusion detection systems.

**CO6:** Apply privacy techniques to protect information in the network.

#### **DETAILED SYLLABUS:**

##### **UNIT I-INTRODUCTION**

**(08 Periods)**

Computer Security Concepts, the OSI Security Architecture, Security Attacks, Security Mechanism, Standards.

**Malicious Software:** Types of Malicious Software, Viruses, Worms, Distributed Denial of Service Attacks.

##### **UNIT II – SECURITY AT TRANSPORT LAYER: SSL & TLS**

**(09 Periods)**

Web Security Consideration, Secure Socket Layer and Transport Layer Security, Transport Layer Security, HTTPS, Secure Shell.

**Wireless Network Security:** IEEE 802.11 Wireless LAN Overview, IEEE 802.11i LAN Security, Wireless Application Protocol Overview, Wireless Transport Layer Security, WAP end-to-end Security

##### **UNIT III – SECURITY AT APPLICATION LAYER: PGP AND S/MIME**

**(08 Periods)**

Pretty Good Privacy, S/MIME, Domainkeys Identified Mail

**IP Security:** IP Security Overview, IP Security Policy, IP Security Architecture, Encapsulating Security Payload, Combining Security Associations, Internet Key Exchange.

##### **UNIT IV- INTRUDERS AND FIREWALLS**

**(08 Periods)**

**Intrusion Detection System:** Intruders, Intrusion Detection, Password Management.

**Firewalls:** The Need for Firewalls, Firewall Characteristics, Types of Firewalls, Firewall Basing, Firewall location and configuration.

**UNIT V- PRIVACY****(09 Periods)**

Evade Traffic analysis, Tunnel SSH through Tor, Encrypt you file seamlessly, Guard against Phishing, Use the web with fewer passwords, Encrypt your E-mail with Thunderbird, Encrypt you E-mail in Mac OS X

**Total Periods: 45**

**Topics for self-study are provided in lesson plan.**

**TEXT BOOKS:**

1. William Stallings "Network Security Essentials (Applications and Standards)", 4<sup>th</sup> Edition, Pearson Education 2011.
2. Andrew Lockhart "Information security Hacks (Tips and Tools for protecting your privacy)", O,ReillyMedia publisher, 2<sup>nd</sup> Edition, 2004.

**REFERENCE BOOKS:**

1. Behrousz A Forouzan, D Mukhopadhyay, "Cryptography and network Security", 1<sup>st</sup> Edition, McGraw Hill,2010.
2. CharlieKaufman, Radia Perlman and Mike Speciner, Network Security – Private Communication in a Public World,2<sup>nd</sup> Edition, Pearson/PHI.

**ADDITIONAL RESOURCES:**

1. [http://www.inf.ufsc.br/~bosco.sobral/ensino/ine5680/material-cripto-seg/20141/Stallings/Stallings\\_Cryptography\\_and\\_Network\\_Security.pdf](http://www.inf.ufsc.br/~bosco.sobral/ensino/ine5680/material-cripto-seg/20141/Stallings/Stallings_Cryptography_and_Network_Security.pdf).
2. <http://www.ijcsmc.com/docs/papers/January2015/V4I1201544.pdf>.
3. <http://nptel.ac.in/syllabus/106105031/>.

**IV B. TECH. – I Semester**  
**(19BM71531) INFORMATION SECURITY LAB**

Int.	Ext.	Total Marks	L	T	P	C
50	50	100	-	-	2	1

**PRE-REQUISITES:** - Course on Information Security.

**COURSE DESCRIPTION:**

Windows Firewall Security Features, Introduction to wireshark tool, Pretty Good Privacy (PGP), Intrusion Detection System, SSL Certificate, and TSL.

**COURSE OUTCOMES:**

After successful completion of this course, the students will be able to:

- CO1. Apply the tools and techniques to ensure the information security and privacy for network applications.
- CO2. Analyze SSL Certificate and encryption in web applications for security.
- CO3. Analyze SSL and TLS protocols to secure TCP connections.
- CO4: Implement IP Packet filtering for blocking in-bound packets.
- CO5. Work independently or communicate effectively in oral and written forms.

**List of Exercises/List of Experiments:**

1. Find the Packet Information using Wireshark on our network.
2. Simulate traffic analyzing using wireshark.
3. Study of SSL (HTTPS) over HTTP to secure TCP connections.
4. Simulate Transport Layer Security protocol.
5. Create a simple web application and deploy it in Apache tomcat server and secure it using SSL certificates.
6. Simulate Pretty Good Privacy security protocol for email messages and individual files.
7. Simulate IP Packet filtering at host system in user Network.
8. Study windows firewall security features on the system allotted to you.
9. Create firewalls using ip tables in linux.

**REFERENCE BOOKS/LABORATORY MANUALS:**

1. Computer Security: Principles and Practices, William Stallings and Lawrie Brown, Pearson Education, ISBN 13-9780134794396
2. Computer Security: Art and Science, by Matt Bishop, Pearson Education, ISBN:9788177584257

**SOFTWARE/Tools used:**

- Windows Fire Wall
- PGP
- SSL
- Tomcat 7.0.104
- Snort
- Java
- Wireshark

**ADDITIONAL LEARNING RESOURCES:**

[https://www.cengage.com/resource\\_uploads/downloads/1111138214\\_259146.pdf](https://www.cengage.com/resource_uploads/downloads/1111138214_259146.pdf)  
<https://www.cmu.edu/iso/aware/presentation/tepperphd.pdf>

<https://nvlpubs.nist.gov/nistpubs/SpecialPublications/NIST.SP.800-12r1.pdf>  
<https://www.cs.unibo.it/babaoglu/courses/security/resources/documents/intro-to-crypto.pdf>  
<http://www.cs.kent.edu/~mallouzi/ccn%20Spring%202014/>

**MINOR DEGREE IN**  
**VLSI AND EMBEDDED SYSTEMS**

**Offering Department:** ELECTRONICS AND COMMUNICATION  
ENGINEERING

**Students of Eligible Branches:** CSE, CSSE, IT, EEE, EIE, ME and CE

**COURSE STRUCTURE**

Year & Semester	Course code	Course title	Contact Periods per week				Scheme of Examination Max. Marks		
			L	T	P	C	Int. Marks	Ext. Marks	Total Marks
III B.Tech. I-Sem (2 Theory+ 1 Lab)	19BM50401	Switching Theory and Logic Design	3	-	-	3	40	60	100
	19BM50402	VLSI Design	3	-	-	3	40	60	100
	19BM50403	Microcontrollers	3	-	-	3	40	60	100
	19BM50431	Digital design Lab	-	-	2	1	40	60	100
III B.Tech. II-Sem. (2 Theory+ 1 Lab)	19BM60401	ARM and AVR Microcontrollers	3	-	-	3	40	60	100
	19BM60402	Testing and Testability	3	-	-	3	40	60	100
	19BM60403	Low Power CMOS VLSI Design	3	-	-	3	40	60	100
	19BM60404	Microprocessors and Microcontrollers	3	-	-	3	40	60	100
	19BM60431	VLSI Lab	-	-	2	1	40	60	100
IV B.Tech. I-Sem. (1 Theory+ 1 Lab)	19BM70401	Embedded Systems	3	-	-	3	40	60	100
	19BM70402	Real Time Systems	3	-	-	3	40	60	100
	19BM70403	System-on-Chip Design and verification	3	-	-	3	40	60	100
	19BM70431	Embedded Systems Lab	-	-	2	1	40	60	100

**Note:** If any student has chosen a course from the above list in their regular curriculum then, he/she is not eligible to opt the same course/s for the Minor degree. It is the responsibility of the student to acquire/complete prerequisite before taking the respective course.

### III B. Tech. – I Semester

#### (19BM50401) SWITCHING THEORY AND LOGIC DESIGN

Int. Marks	Ext. Marks	Total Marks	L	T	P	C
40	60	100	3	-	-	3

#### PRE-REQUISITES: -

**COURSE DESCRIPTION:** Number system and Boolean algebra; Minimization; Analysis and synthesis of digital circuits; Asynchronous Sequential Logic & Programmable Memories.

#### COURSE OUTCOMES:

After successful completion of this course, the students will be able to:

- CO1. Demonstrate the knowledge of Boolean Algebra, various number systems and Logic gates to implement Digital Circuits.
- CO2. Design subsystem by Analyzing combinational & sequential logic circuits for providing optimal solutions
- CO3. Develop Asynchronous sequential logic and programmable memories for societal needs.
- CO4. Design various programmable logic arrays using logic gates

#### DETAILED SYLLABUS:

##### UNIT- I: NUMBER SYSTEMS AND BOOLEAN ALGEBRA (10 Periods)

Digital systems, Binary Numbers, Number base conversions, Complements of numbers, Signed binary numbers, Binary codes, Error detection and correction codes. Boolean Algebra-Basic definition, Basic theorems and properties, Boolean Functions, Canonical & Standard forms, logic operations & Logic gates.

##### UNIT- II: GATE LEVEL MINIMIZATION (8 Periods)

The map method, four variable, Five variable K-map, POS & SOP Simplification, Don't care conditions, NAND & NOR Implementation, Other two level Implementation, Ex-or Function, Tabular Method- Simplification of Boolean function using tabulation Method.

##### UNIT- III: COMBINATIONAL LOGIC DESIGN (9 Periods)

Combinational circuits, Analysis & Design procedure, Binary Adder-Sub tractor, Decimal Adder, Binary Multiplier, Magnitude comparator, Decoder, Encoders, Multiplexers and De- Multiplexers.

##### UNIT- IV: SEQUENTIAL LOGIC DESIGN (11 Periods)

Sequential Circuits, Latches, Flip-Flops, Analysis of Clocked sequential circuits, State Reduction & Assignment, Design procedure, Introduction to Registers-Universal Shift Registers, Introduction to Counters, Ripple Counters-Binary and BCD Ripple Counter , Synchronous counters-Binary, Up-Down Binary Counter and BCD Counter and Other counters-Ring Counter, Johnson Counter.



**UNIT- V: ASYNCHRONOUS SEQUENTIAL LOGIC AND PROGRAMMABLE MEMORIES (7 Periods)**

Introduction, Analysis procedure, Design Procedure-Primitive Flow Table, Reduction of State and Flow Tables-Implication Table and Implied States, Hazards, ROM, PLA, PAL.

**Total Periods: 45**

***Topics for Self Study are provided in the Lesson Plan***

**TEXT BOOK:**

1. M. Morris Mano, Michael D. Ciletti, *Digital Design With an Introduction to the Verilog HDL*, Pearson, 5<sup>th</sup> edition, 2017.

**REFERENCE BOOKS:**

1. A. Anand Kumar, *Switching Theory and Logic Design*, PHI Learning Private Limited, 3<sup>rd</sup> edition, India, 2017.
2. Charles H. Roth, Jr. and Larry L. Kinney, *Fundamentals of Logic Design*, Cengage Learning, 7<sup>th</sup> edition, 2015

### III B. Tech. – I Semester

#### (19BM50402) VLSI Design

Int. Marks	Ext. Marks	Total Marks	L	T	P	C
40	60	100	3	-	-	3

**PRE-REQUISITES:** A Course on Switching Theory and Logic Design/Digital Logic Design.

**COURSE DESCRIPTION:** Logic Families; CMOS Technology; Stick Diagrams and Layouts; Subsystem design; Programmable Interconnect structures; Memories.

**COURSE OUTCOMES:** After successful completion of this course, the students will be able to:

- CO1 Analyze logic families, steady state and dynamic characteristics of CMOS, to improve performance characteristics of digital ICs.
- CO2 Analyze electrical properties of MOS circuits for VLSI/ULSI chip fabrication.
- CO3 Develop stick diagrams and layouts of CMOS circuits for miniaturization by analyzing gate delays and scaling effects.
- CO4 Design subsystems for High speed digital electronics to compensate tradeoff among area, speed and power requirements.

#### DETAILED SYLLABUS:

##### UNIT I - DIGITAL LOGIC FAMILIES (8 Periods)

Introduction to logic families, RTL, DTL, Transistor-Transistor logic, Emitter Coupled Logic, I<sup>2</sup>L, CMOS logic, CMOS steady state and dynamic electrical behavior.

##### UNIT II - FABRICATION AND ELECTRICAL PROPERTIES OF MOS (10 Periods)

Fabrication Process for NMOS and CMOS technology, Basic Electrical Properties of MOS:  $I_{ds} - V_{ds}$  relationships, Second order effects of MOSFETs-Latch up, Hot carrier Effects, channel length modulation, Threshold Voltage  $V_T$ ,  $g_m$ ,  $g_{ds}$  and  $\omega_0$ ; Pass Transistor, NMOS inverter, Pull up to pull down ratio for an NMOS inverter, CMOS Inverter

##### UNIT III - CMOS CIRCUIT DESIGN PROCESS (10 Periods)

VLSI design flow, MOS layers, stick diagrams, NMOS design style, CMOS design style, lambda based design rules, layouts for inverters, sheet resistance, capacitances of layers, Gate delays, Delay estimation, Scaling, Limitations of Scaling.

##### UNIT IV - SUBSYSTEM DESIGN - I (08 Periods)

Adders – Transmission based Adder, Carry look-ahead adder, Manchester carry chain adder, Carry Skip Adder, Carry Select Adder; Barrel Shifter, Multipliers – Array Multiplier, Booth Multiplier; ALUs.

##### UNIT V - SUBSYSTEM DESIGN - II (09 Periods)

Counters- Synchronous and Asynchronous Counter; High Density Memory Elements - Design Approach, FPGAs, Programmable Interconnect structures - Fusible links, Antifuse via link, UV Erasable, Electrically Erasable; CPLDs, Cell based Design Methodology.

**Total Periods: 45**

**Topics for Self Study are provided in the Lesson Plan**

**TEXT BOOKS:**

1. Kamran Eshraghian, Douglas A. Pucknell and sholeh Eshraghian, *Essentials of VLSI Circuits and Systems*, PHI, 2005.
2. Morris Mano, *Digital Design*, Prentice Hall, 3<sup>rd</sup> Edition, 2003 .

**REFERENCE BOOKS:**

1. John F.Wakerly, *Digital Design Principles & Practices*, Pearson Education Asia, 4<sup>th</sup> Edition, 2008.
2. John M. Rabaey, *Digital Integrated Circuits: A Design Perspective*, PHI, 2<sup>nd</sup> Edition, 2003.

**III B. Tech. - I semester**  
**(19BM50403) MICROCONTROLLERS**

Int. Marks	Ext. Marks	Total Marks	L	T	P	C
40	60	100	3	-	-	3

**PRE-REQUISITES:** A Course on Switching Theory and Logic Design/Digital Logic Design.

**COURSE DESCRIPTION:** 8051 Microcontroller - Architecture, programming, interrupts and applications; PIC microcontroller architecture, Interrupts and timers of PIC microcontroller, interfacing

**COURSE OUTCOMES:**

After successful completion of this course, the students will be able to:

- CO1. Analyze Architectural features and Instruction Set of 8051 for control applications.
- CO2. Analyze PIC18 Architecture and Instruction Set to develop computing applications.
- CO3. Develop Programs for PIC18 using ports, timers and associated on Chip resources for Specified Applications.
- CO4. Design microcomputer based systems with the knowledge of Interfaces and Peripherals of PIC18 to Solve various engineering problems.

**DETAILED SYLLABUS:**

**UNIT I: 80C51/31 (10 Periods)**

Microprocessors vs Microcontrollers, 8051 Architecture, Internal and external memories, Addressing modes, Timers/Counters structure & configuration, Instruction set of 8051, simple programs using 8051.

**UNIT II: PIC ARCHITECTURE & PROGRAMMING (10 Periods)**

Architecture of PIC18, Register Organization, Memory Organization - ROM space & RAM; Data formats & Directives, Instruction Set: Arithmetic, Logic, branching, Bit wise, bank switching, Simple PIC Programs.

**UNIT- III: PORTS, TIMERS & PROGRAMMING (10 Periods)**

Pin description of PIC18F452, Basic Port Structure, I/O port programming; Macros and modules, Structure of Timer 0 & its Programming using Assembly and C, Counter programming, Structure of timers 1, 2 and 3 & their Programming.

**UNIT- IV: PIC - SERIAL PORT AND INTERRUPTS (7 Periods)**

Basics of communication - Serial/Parallel, RS232 & PIC18 connection to RS232, Serial Port Structure & programming; PIC18 interrupts, Programming timer interrupts, Programming serial interrupts.

**UNIT- V: PIC INTERFACING (8 Periods)**

7 segment LED and LCD interfacing, keyboard interfacing, interfacing ADC, DAC,

Interfacing DC motor, stepper motor, PWM using CCP.

**Total Periods: 45**

**Topics for Self Study are provided in the Lesson Plan**

**TEXT BOOKS:**

1. Muhammad Ali Mazidi and Janice Gillespie Mazidi and Rollin D, *The 8051 Microcontroller and Embedded Systems-using assembly and C*, PHI, 2006/ Pearson New International Edition 2014
2. Muhammad Ali Mazidi, Rolin D. McKinlay, Danny causey, *PIC Microcontroller and Embedded Systems: Using C and PIC18*, Pearson Education, 2015.

**REFERENCE BOOKS:**

1. Kenneth J. Ayala, *The 8051 Microcontroller-Architecture, Programming & Applications*, 3<sup>rd</sup> Edition, Cengage learning, June 2007.
2. Ramesh S. Gaonkar, *Fundamentals of Microcontrollers and Applications in Embedded Systems (With PIC18 Microcontroller Family)*, Penram International, 2010.
3. M Rafiquzzaman, *Microcontroller Theory And Applications With The PIC*, Wiley India Publications, March 2014

**ADDITIONAL LEARNING RESOURCES:**

1. <http://crystal.uta.edu/~zaruba/CSE3442/>
2. <https://owd.tcnj.edu/~hernande/ELC343/>
3. <http://www.ciebookstore.com/Content/Images/uploaded/PIC18-Study-Guide-CIE.pdf>

### III B. Tech. – I Semester

#### (19BM50431) DIGITAL DESIGN LAB

Int. Marks	Ext. Marks	Total Marks	L	T	P	C
40	60	100	-	-	2	1

**PRE-REQUISITES:** Courses on Switching Theory and Logic Design/Digital Logic Design & Electronic Devices and Circuits.

**COURSE DESCRIPTION:** Design and verification of Digital Circuits, PCB Design of Electronic Circuits.

#### **COURSE OUTCOMES:**

After successful completion of this course, the students will be able to:

- CO1. Design and Realize various Digital applications by using ICs for societal needs.
- CO2. Implement Electronic Circuits using Passive and Active elements for specified applications.
- CO3. Analyze performance parameters for PCB designed circuits using a simulation tool.
- CO4. Work independently and in teams to solve problems with effective Communication.

#### **LIST OF EXERCISES/LIST OF EXPERIMENTS:**

##### **Part-A: Realize the Following in Hardware**

(Minimum **Six** Experiments are to be conducted)

1. Realize gates using NAND & NOR gates.
2. Optimize and Realize a given Boolean Function.
3. Design and Realize BCD to Excess-3 Code Converter.
4. Design and Realize Adder and Subtractor using Multiplexer based on logic gates/ IC74153.
5. Design and Realize a BCD to 7-Segment Decoder using Logic Gates/ ICs.
6. Design and Realize a Hexadecimal to Binary Encoder using IC74148 and IC74157.
7. Design and Realize a Sequence Generator using IC7495.
8. Design and Realize Asynchronous and Synchronous counters using IC7476 (JK-Flip Flop).

##### **Part-B: PCB Layout Design of Electronic Circuits using TINAPRO/ eSIM-KiCAD/ TinyCAD/ Fritzing Software**

(Minimum **Four** Experiments are to be conducted)

1. RC Filter.
2. Half Wave Precision Rectifier.
3. Zener Regulator.
4. Diode Clamper.
5. Transistor as a Switch.
6. CMOS Inverter.

**REFERENCE BOOKS/LABORATORY MANUALS:**

1. John F. Wakerly, *Digital Design Principles & Practices*, Pearson Education Asia, 4<sup>th</sup> Edition, 2008.

**SOFTWARE/Tools used:** TINAPRO/ eSIM-KiCAD/ TinyCAD PCB Design Tool.

**ADDITIONAL LEARNING RESOURCES:**

1. [http://vlabs.iitb.ac.in/vlabsdev/vlab\\_bootcamp/bootcamp/cool\\_developers/index.html](http://vlabs.iitb.ac.in/vlabsdev/vlab_bootcamp/bootcamp/cool_developers/index.html)  
| - Virtual labs for digital circuits
2. <https://nptel.ac.in/courses/108/108/108108031/>
3. [https://swayam.gov.in/nd2\\_aic20\\_sp59/preview](https://swayam.gov.in/nd2_aic20_sp59/preview)

### III B. Tech. – II Semester

#### (19BM60401) ARM AND AVR CONTROLLERS

Int. Marks	Ext. Marks	Total Marks	L	T	P	C
40	60	100	3	-	-	3

**PRE-REQUISITES:** Courses on Switching Theory and Logic Design/Digital Logic Design, & Microcontrollers

**COURSE DESCRIPTION:** ARM Architecture; ARM Instruction Set; ARM Programming; AVR Architecture; AVR Programming in Assembly Language & C

#### **COURSE OUTCOMES:**

After successful completion of this course, the students will be able to:

- CO1. Analyze ARM Architectures and Instruction Set to develop fundamental Programs .
- CO2. Develop efficient ARM based Prototypes by analyzing modes of ARM operation to program ARM Cortex M3 at Assembly and high levels.
- CO3. Realize efficient Embedded Systems with an understanding of limitations by evaluating architectural features of AVR Family Microcontrollers .
- CO4. Apply Programming techniques at Assembly and High Level to develop industry standard microcontroller based systems.

#### **DETAILED SYLLABUS:**

##### **UNIT- I: Introduction to ARM Architecture (9 Periods)**

Introduction to ARM family of processors and controllers, Architecture of ARM Cortex M3, Cortex M3 fundamentals, registers, Operation modes, ARM Instruction Set: Data transfer, Data Processing Call & Branch, Bit Manipulation, Pseudo Instructions and other useful instructions in Cortex M3, ARM Assembly Language Programming.

##### **UNIT -II: Thumb Programming & other ARM features (9 Periods)**

Thumb Instruction Set, ARM Mode & Thumb mode Programming, ARM Programming in C. Memory system, memory map, Memory system attributes, ARM Pipeline, Exception types, Cortex M3 Processor applications.

##### **UNIT III: INTRODUCTION to AVR MICROCONTROLLER (9 Periods)**

Overview of AVR family, AVR Microcontroller architecture, status register, Special function registers, RAM, ROM & EEPROM space, On-Chip peripherals, ATmega32 pin configuration & function of each pin, Fuse bits of AVR.

##### **UNIT IV: AVR ASSEMBLY LANGUAGE PROGRAMMING (10 Periods)**

AVR data types and assembler directives, Addressing modes of AVR, Data transfer, Arithmetic, Logic and Compare, Rotate and Shift, Branch and Call instructions, AVR studio setup for assembly language programming, AVR I/O Port Programming, Time delay loop, Look-up table, Bit addressability, MACROS, Intel HEX file.

##### **UNIT V: AVR PROGRAMMIN IN C (8 Periods)**

AVR Data types, AVR I/O port programming, Timer programming, Input capture and Wave Generator, PWM programming External Interrupt programming, ADC programming, EEPROM programming.



**Topics for Self Study are provided in the Lesson Plan**

**TEXT BOOKS:**

1. Joseph Yiu, *The Definitive Guide to the ARM Cortex-M3 & M4*, Elsevier, 3<sup>rd</sup> Edition, January 2014.
2. Muhammad Ali Mazidi, SarmadNaimi and SepehrNaimi, *The AVR Microcontroller and Embedded Systems Using Assembly and C*, Pearson Education, January 2014.

**REFERENCE BOOKS:**

1. Ramesh Gaonkar, *Fundamentals of Microcontrollers and Applications in Embedded Systems (with the PIC18 Microcontroller Family)*, Penram International, First edition, 2010.
2. Andrew Sloss, Dominic Symes, Chris Wright, *ARM System Developer's Guide: Designing and Optimizing System Software (The Morgan Kaufmann Series in Computer Architecture and Design)*, October 2004.
3. AVR ATmega32 data sheet

### III B. Tech. – II Semester

#### (19BM60402) TESTING AND TESTABILITY

Int. Marks	Ext. Marks	Total Marks	L	T	P	C
40	60	100	3	-	-	3

**PRE-REQUISITES:** A Course on VLSI Design.

**COURSE DESCRIPTION:** Need for Testing, Types of Testing, Fault Modeling, Test Methods for evaluation, Test Generation Algorithms, Delay Tests, IDDQ Tests, Ad-Hoc DFT Methods, Scan Based Designs, Built-In Self Test.

#### **COURSE OUTCOMES:**

After successful completion of this course, the students will be able to:

- CO1 Understand the importance of Testing, fault models and related theorems.
- CO2 Analyze various test methods, combinational and sequential circuit test generation Algorithms for Functional Verification of Digital Circuits.
- CO3 Analyze delay test algorithms and IDDQ test algorithms for at-speed testing of CMOS Integrated Circuits.
- CO4 Understand the concepts and architectures for Built-In Self Test to satisfy industry specifications.
- CO5

#### **DETAILED SYLLABUS:**

##### **UNIT I- INTRODUCTION TO TESTING (09 Periods)**

Role of Testing, VLSI Technology Trends Affecting Testing, Types of Testing, Test Economics, Yield, Fault Modeling, Fault Equivalence, Fault Collapsing, Fault Dominance and Checkpoint Theorem.

##### **UNIT II – TEST METHODS (10 Periods)**

Simulation for Design Verification and Test Evaluation, Algorithms for Fault Simulation – Serial, Parallel, Deductive, Concurrent Fault Simulations; Fault Sampling.

##### **UNIT III – COMBINATIONAL AND SEQUENTIAL CIRCUIT TEST GENERATION (11 Periods)**

ATPG Algorithms – D-Algorithm, PODEM, FAN; Test Compaction, Time Frame Expansion Method – Nine-Value Algorithm; Simulation Based Sequential ATPG - CONTEST Algorithm.

##### **UNIT IV – DELAY AND IDDQ TESTS (06 Periods)**

Delay Test – Path-Delay Test, Transition Faults, At-Speed Testing; IDDQ Test – Limitations, Delta IDDQ Testing, IDDQ Built-in Current Testing.

##### **UNIT V – DESIGN FOR TESTABILITY (Periods: 09)**

Ad-Hoc DFT Methods, Full Scan Design, Partial Scan Design, Random Logic BIST – Test-per-Clock and Test-per-Scan BIST Systems; Boundary Scan Standard – TAP Controller and Port.

**Total Periods: 45**

***Topics for Self Study are provided in the Lesson Plan***

**TEXT BOOK:**

1. Michael L. Bushnell, Vishwani D. Agrawal, "Essentials of Electronic Testing for Digital, Memory and Mixed-Signal VLSI Circuits", Kluwer Academic Publishers, Springer US, New York, 2006.

**REFERENCE BOOKS:**

1. Miron Abramovici, Melvin A. Breuer, Arthur D.Friedman, "Digital Systems Testing and Testable Design", Wiley, Jaico Publishing House, 1<sup>st</sup> Edition, 2001.
2. Alfred L. Crouch, "Design for Test for Digital ICs & Embedded Core Systems", Pearson Education, 1<sup>st</sup> Reprint Edition, 2007.
3. Robert J.Feugate, Jr., Steven M.McIntyre, "Introduction to VLSI Testing", Prentice Hall, 1st Illustrated Edition,1998.

**ADDITIONAL LEARNING RESOURCES:**

1. <https://www.classcentral.com/course/swayam-digital-vlsi-testing-7956>

### III B. Tech. - II semester

#### (19BM60403) LOW POWER CMOS VLSI DESIGN

Int. Marks	Ext. Marks	Total Marks	L	T	P	C
40	60	100	3	-	-	3

**PRE-REQUISITES:** A Course on VLSI Design.

**COURSE DESCRIPTION:** Basic Principles; Methodologies and techniques of CMOS Circuit Designs; Need For Low Power VLSI Design; Principles Of Low Power Circuit Design; Simulation Analysis of Low Power; Logic and Circuit Analysis; Special Techniques and Advanced Techniques Of Low Power Design; Performance Management in Architecture or System level.

#### **COURSE OUTCOMES:**

After successful completion of this course, the students will be able to

- CO1. Demonstrate low power design requirements for CMOS VLSI circuits.
- CO2. Analyze and estimate power at Logic and Circuit abstraction levels of digital systems.
- CO3. Develop alternate circuits and logic for analysis of low power circuits.
- CO4. Apply special and advanced low power techniques at circuit, architecture and system levels to develop CMOS devices.

#### **DETAILED SYLLABUS:**

##### **UNIT-I: BASICS OF LOW POWER DESIGN (07 Periods)**

Needs For Low Power VLSI Chips, Charging And Discharging Capacitances, Short Circuit Current in CMOS, CMOS Leakage Current, Static Current, Basic Principles Of Low Power Design, Low Power Figure Of Merits, Low Power VLSI Design Limits.

##### **UNIT-II: POWER ANALYSIS AND ESTIMATION (10 Periods)**

Spice Circuit Simulation, Discrete Transistor Modeling and Analysis, Gate Level Logic Simulation, Architecture Level Analysis, Data Correlation Analysis, Monte Carlo Simulation.

##### **UNIT-III: LOW POWER CIRCUITS (11 Periods)**

**CIRCUIT ANALYSIS:** Transistor and Gate Sizing, Equivalent Pin Ordering, Network Restructuring and Reorganization, Special latches and Flip flops.

**LOGIC ANALYSIS:** Gate Reorganization, Signal Gating, Logic Encoding, State Machine Encoding, Pre computation Logic.

##### **UNIT-IV: SPECIAL TECHNIQUES (08 Periods)**

Power Reduction in Clock Networks, CMOS Floating Node, Low Power Bus, Delay Balancing, Low Power Techniques for SRAM.

**UNIT-V: ARCHITECTURE, SYSTEM & ADVANCED TECHNIQUES (09 Periods)**

Power and Performance Management, Switching Activity Reduction, Adiabatic Computation, Pass Transistor Logic Synthesis, Asynchronous Circuit.

**Total Periods: 45**

***Topics for Self Study are provided in the Lesson Plan***

**TEXT BOOK:**

1. Gary Yeap, *Practical Low-Power Digital VLSI Design*, Springer Publication, 2012.

**REFERENCE BOOKS:**

1. A.P.Chandrakasan, R.W.Brodersen, *Low Power Digital CMOS Design*, Kluwer, Springer US, 2012.
2. Kaushik Roy, Sharat Prasad, *Low-Power CMOS VLSI Circuit Design*, Wiley Student Edition, 2009.

**ADDITIONAL LEARNING RESOURCES:**

<https://nptel.ac.in/courses/106/105/106105034/>

<https://nptel.ac.in/courses/117/101/117101004/>

### III B. Tech. - II semester

#### (19BM60404) MICROPROCESSORS AND MICROCONTROLLERS

Int. Marks	Ext. Marks	Total Marks	L	T	P	C
40	60	100	3	-	-	3

**PRE-REQUISITES:** A Course on Switching Theory and Logic Design/Digital Logic Design.

**COURSE DESCRIPTION:** Architecture, Instruction set and programming of 8086; Programmable interfacing devices - architecture and programming; Interfacing Memory and I/O devices with 8086; 8051 Microcontroller - Architecture, programming, interrupts and applications.

#### **COURSE OUTCOMES:**

After successful completion of this course, the students will be able to:

- CO1. Analyze Architectural features and Instruction Set of 8086 for computing applications.
- CO2. Analyze Techniques for Interfacing various peripherals to realize Microcomputer based systems
- CO3. Analyze Architectural features and Instruction Set of 8051 for control applications.
- CO4. Design various embedded applications programming 8051 on-chip Resources and by interfacing various peripherals.

#### **DETAILED SYLLABUS:**

#### **UNIT - I: 8086 ARCHITECTURE AND PROGRAMMING (10 Periods)**

Microprocessor Evolution, Review of Intel 8085, 8086 internal Architecture - register organization, memory segmentation, memory organization; Introduction to programming the 8086 - Assembler directives, addressing modes, instruction set, simple programs, procedures and macros;

#### **UNIT - II: 8086 INTERFACING AND INTERRUPTS (08 Periods)**

Pin description, minimum & maximum mode operation of 8086, timing diagram. Interfacing memory (RAM and EPROM) to 8086. 8086 Interrupts - types and interrupt responses, Interrupt vector table, priority of interrupts; 8259 priority interrupt controller - architecture, system connections and cascading, initialization of 8259;

#### **UNIT - III: PROGRAMMABLE DATA COMMUNICATION DEVICES (11 Periods)**

Introduction to serial and parallel communication, methods of parallel data transfer. 8255 PPI - Internal architecture and system connections, operational modes and initialization, interfacing stepper motor, ADC, DAC, Optical Shaft Encoder; Methods of serial data transfer, 8251 USART - architecture and its initialization, sending and receiving characters; Serial communication standard - RS232C, USB; Architecture and operation of 8257 DMA controller.

#### **UNIT - IV: MICROCONTROLLERS AND PROGRAMMING (08 Periods)**

Microcontroller Vs. General purpose microprocessor, 8051/8052 Microcontroller - architecture, features, register organization, pin diagram, internal and external memories & their interfacing, instruction set, addressing modes, simple programs;

**UNIT - V: 8051 INTERFACING****(08 Periods)**

Timer/Counters – Registers, modes and programming; Serial communication – registers, programming 8051 for serial communication; Interrupts – registers, programming; 8051 applications – Interfacing key board, LEDs and LCD;

**Total Periods: 45**

***Topics for Self Study are provided in the Lesson Plan***

**TEXT BOOKS:**

1. Douglas V. Hall, *Microprocessors and Interfacing: Programming and Hardware*, Tata McGraw-Hill, revised 2<sup>nd</sup> Edition, 2006.
2. Muhammad Ali Mazidi and Janice Gillispie Mazidi, *The 8051 Microcontroller and Embedded Systems*, Prentice Hall of India, 2000.

**REFERENCE BOOKS:**

1. A.K. Ray and K.M. Bhurchandi, *Advanced Microprocessors and Peripherals-Architecture, Programming and Interfacing*, Tata McGraw Hill, 2002 reprint.
2. Kenneth J. Ayala, *The 8051 microcontroller, Thomson Delmar learning*, 3<sup>rd</sup> Edition, 2004.

## III B. Tech. – II Semester

### (19BM60431) VLSI LAB

Int. Marks	Ext. Marks	Total Marks	L	T	P	C
40	60	100	-	-	2	1

**PRE-REQUISITES:** A course on Switching Theory and Logic Design/ Digital Logic Design.

**COURSE DESCRIPTION:** Design and verification of various combinational & sequential digital circuits through source code.

#### **COURSE OUTCOMES:**

After successful completion of this course, the students will be able to:

- CO1. Analyze simplification methods in logic circuits and perform desired logical operations optimally using logic gates.
- CO2. Design combinational circuits to perform arithmetic operations, data encoding and decoding, Multiplexing and Demultiplexing for engineering applications.
- CO3. Design sequential circuits for realizing counters and registers using flip-flops.
- CO4. Develop source code for Advanced Digital Design and perform functional verification.
- CO5. Work independently or in teams to solve problems with effective Communication.

#### **LIST OF EXERCISES/LIST OF EXPERIMENTS:**

##### **Part-A: Basic Digital Design**

*(Minimum **SEVEN** experiments are to be conducted)*

Develop the source code for the following circuits and their test bench for verification. Also perform simulation, synthesis for given specifications

1. Buffer and basic gates.
2. Flip flops - RS, D, JK, T.
3. Adders and Subtractors.
4. 8-3 Encoder.
5. 3-8 Decoders.
6. 8x1 Multiplexer and 2x4 Demultiplexer.
7. Arithmetic and Logic Unit.
8. Synchronous & Asynchronous counter.
9. 4 Bit Comparator

##### **Part-B: Advanced Digital Design (FPGA Implementation)**

*(Minimum **THREE** Experiments are to be conducted)*

1. Write Verilog code for the design of 8-bit
  - i. Carry Ripple Adder
  - ii. Carry Look Ahead adder
  - iii. Carry Save Adder



2. Write Verilog Code for the design of 8-bit
  - i. Array Multiplier (Signed and Unsigned)
  - ii. Booth Multiplier (Radix-4)
3. Write Verilog code for the design of 4/8-bit
  - i. Universal Shift Register
  - ii. Parity Generator
4. Write Verilog code for the design of 4/8-bit
  - i. Pseudo Random Pattern Generator
  - ii. LFSR
5. Design a Mealy and Moore Sequence Detector using Verilog to detect Sequence.  
Eg. 11101 (with and without overlap) any sequence can be specified

Note: (For the experiments listed above, students can make the following flow of study  
 -RTL synthesis  
 -creation of power Analysis  
 -use of I/O constrains)

#### **REFERENCE BOOKS/LABORATORY MANUALS:**

1. M. Morris Mano, Digital Design, Pearson Education, 5th edition, 2013.
2. Charles H. Roth, Fundamentals of Logic Design, Thomson Publications, 5<sup>th</sup> edition, 2004.
3. John F. Wakerly, Digital Design Principles & Practices, Pearson Education Asia, 4th Edition, 2008.
4. Stephen Brown and Zvonko Vranesic, Fundamentals of Digital Logic with VHDL Design, McGraw Hill, 2<sup>nd</sup> Edition, 2005.

#### **SOFTWARE/Tools used:**

CADENCE/SYNOPSYS/MENTOR GRAPHICS/TANNER or any other equivalent Tool  
 FPGA/CPLD Boards with Xilinx or any other equivalent

#### **ADDITIONAL LEARNING RESOURCES:**

1. <http://www.vlab.co.in>
2. <https://swayam.gov.in>

## IV B. Tech. – I Semester

### (19BM70401) EMBEDDED SYSTEMS

Int. Marks	Ext. Marks	Total Marks	L	T	P	C
40	60	100	3	-	-	3

**PRE-REQUISITES:** A Course on Microcontrollers/Microprocessors and Microcontrollers.

**COURSE DESCRIPTION:** MSP430 Architecture; Instruction Set; Programming; On-Chip Resources; Communication with peripherals; Embedded system design approaches.

**COURSE OUTCOMES:** After successful completion of this course, the students will be able to:

- CO1. Analyze MSP430 Architecture, Instruction Set, Addressing modes to develop programs for various control applications using Assembly and Embedded C.
- CO2. Solve Problems by analyzing MSP430 On Chip Resources such as Timer, Clock System, Low Power Modes/techniques and Interrupt Structure.
- CO3. Realize Mixed Signal Processing and Networking Applications, by analyzing on-Chip Resources such as Comparator, ADC, Temperature Sensor, PWM and Communication Peripherals.
- CO4. Analyze Language, IDE Support, Processor IC & Design Technologies, and System Modeling Techniques to capture behavior of Embedded Prototype using suitable model.

#### DETAILED SYLLABUS:

##### **UNIT- I: ARCHITECTURE OF MSP430 (09 periods)**

Embedded Systems – Introduction, MSP430 - Anatomy of microcontroller, Memory, Software, Pin out (MSP430G2553), Functional Block diagram, Memory, CPU, and Memory mapped input and output, Clock generator; Exceptions- Interrupts and Resets.

##### **UNIT- II: PROGRAMMING MSP430 (09 periods)**

Development Environment, Aspects of C for Embedded Systems, Assembly Language, Register Organization, Addressing Modes, Constant Generator and Emulated Instructions, Instruction Set, Example programs- Light LEDs, Read input from a switch; Automatic Control-Flashing light by delay, use of subroutines and Functions; Basic Clock System, Interrupts and Low Power Modes.

##### **UNIT- III: TIMERS AND MIXED SIGNAL SYSTEMS (09 periods)**

Timers - Watchdog Timer, RTC, Timer A, Measurement in capture mode, PWM generation; Mixed Signal Systems- Comparator A, ADC10 SAADC –Architecture, operation- Single Conversion, Temperature Sensor on ADC10, DTC in ADC10; ADC12 – Comparison with ADC10.

##### **UNIT- IV: COMMUNICATION PERIPHERALS & PROTOCOLS (09 periods)**

MSP430 Communication Interfaces- USART, USCI, USI;  
Communication Protocols- SPI, Inter-integrated Circuit Bus, USB, CAN

**UNIT - V: EMBEDDED SYSTEM DESIGN****(09 periods)**

Processor Technology, IC Technology, Design Technology, Tradeoffs.  
Model VS. Language, System Modelling – Data Flow Model, FSM, FSM D, HCFSM, PSM,  
Concurrent Process Model & implementation.

**Total Periods: 45*****Topics for Self Study are provided in the Lesson Plan*****TEXT BOOKS:**

1. John H. Davies, *MSP430 Microcontroller Basics*, Newnes Publications, 1<sup>st</sup> Edition, 2008.
2. Santanu Chattopadhyay, *Embedded System Design*, PHI, 2010.
3. Frank Vahid, Tony D. Givargis, *Embedded System Design – A Unified Hardware/Software Introduction*, John Wiley, January 2006

**REFERENCE BOOKS:**

1. Chris Nagy, *Embedded Systems Design using the TI MSP30 Series*, Newnes Publications, October 2003.
2. Jorgeon Staunstrup, Wayne Wolf, *Hardware/Software Co-design Principles and Practice*, Springer 2009.
3. Patrick R Schamont, *A Practical Introduction to Hardware/Software Co-design*, Springer publications, January 2010

## IV B. Tech. – I Semester

### (19BM70402) REAL TIME SYSTEMS

Int. Marks	Ext. Marks	Total Marks	L	T	P	C
40	60	100	3	-	-	3

**PRE-REQUISITES:** Courses on Microcontrollers/ Microprocessors and Microcontrollers & Embedded Systems.

**COURSE DESCRIPTION:** Real Time Systems Modeling; Scheduling Approaches ; Multiprocessor and Distributed Scheduling Algorithms; Fault Tolerant Systems; Real Time Operating Systems.

#### **COURSE OUTCOMES:**

After successful completion of this course, the students will be able to:

- CO1. Analyze Real Time System Characterization, Workload and Resource management algorithms and apply suitable techniques to model hard and soft real time systems.
- CO2. Solve scheduling problems and apply suitable techniques in constrained RT systems by Surveying various Real Time scheduling approaches for uniprocessor, Multiprocessor and distributed environments.
- CO3. Evaluate appropriate Fault tolerant techniques and apply them to design fail safe RT systems.
- CO4. Implement Efficient Real Time Systems porting suitable operating system on to hardware by Investigating POSIX standard Kernel structure, services and Kernel objects.

#### **DETAILED SYLLABUS:**

##### **UNIT-I: MODELING OF REAL TIME SYSTEMS (9 Periods)**

Hard Vs Soft Real Time Systems, A Reference Model of Real Time Systems- Processors and Resources, Temporal Parameters of Real Time Workload, Periodic Task Model, Precedence Constraints and Data Dependency. Functional Parameters, Resource Parameters of Jobs and Parameters of Resources, Scheduling hierarchy.

##### **UNIT-II: APPROACHES TO REAL TIME SCHEDULING (9 Periods)**

Clock Driven, Weighted Round Robin, Priority Driven, Dynamic Vs Static Systems, Effective Release Times and Dead Lines, Optimality and Non-optimality of EDF and LST algorithms, Challenges in Validating Timing Constraints in Priority Driven Systems, Offline Vs Online Scheduling.

##### **UNIT-III: SCHEDULING REAL TIME TASKS IN MULTIPROCESSOR AND DISTRIBUTED SYSTEMS (9 Periods)**

Multiprocessor task allocation, Dynamic allocation of tasks, Fault tolerant scheduling of tasks, Clocks in distributed Real Time Systems, Centralized clock distribution, Distributed clock synchronization.

##### **UNIT-IV: FAULT TOLERANCE TECHNIQUES (9 Periods)**

Introduction, Failures- Causes, Types, Detection. Fault and Error Containment, Redundancy- Hardware, Software, Time, Integrated Failure Handling.

**UNIT-V: OPERATING SYSTEMS****(9 Periods)**

Overview- Threads and Tasks, the Kernel. Time Services and Scheduling Mechanisms, Basic Operating System Functions- Communication and Synchronization, Event Notification and Software Interrupt Memory Management, I/O and Networking. Processor Reserves and Resource Kernel, Capabilities of Commercial Real Time Operating Systems.

**Total Periods: 45**

***Topics for Self Study are provided in the Lesson Plan***

**TEXT BOOKS:**

1. Jane W.S. Liu, "Real Time Systems", Pearson Education, 1st Edition, 2006.
2. Rajib Mall, "Real Time Systems-Theory and Practice", Pearson Education India, 1<sup>st</sup> Edition, Nov.2012.
3. C. M. Krishna, Kang G Shin, "Real Time Systems", MCgraw-Hill Series, Dec. 1996.

**REFERENCE BOOKS:**

1. Phillip A. Laplante and Seppo J. Ovaska, "Real-Time Systems Design and Analysis: Tools for the Practitioner", Wiley-IEEE Press, 4th edition, Nov. 2011.
2. Hermann Kopetz, "Real-Time Systems: Design Principles for Distributed Embedded Applications ", Springer; 2nd Edition, 2011.

## IV B. Tech. – I Semester

### (19BM70403) **SYSTEM-ON-CHIP DESIGN AND VERIFICATION**

Int.	Ext.	Total	L	T	P	C
40	60	100	3	-	-	3

**PRE-REQUISITES:** A Course on VLSI Design.

**COURSE DESCRIPTION:** System on Chip Design (SOC) Process; System level Design Issues; Test Strategies; Macro Design and Verification; Reusable Macros; System on Chip Verification; Communication Architectures for SoCs.

#### **COURSE OUTCOMES:**

After successful completion of this course, the students will be able to:

- CO1. Demonstrate various SoC Design aspects and issues in low power and high speed Implementations.
- CO2. Analyze the Macro Design Process to solve issues in usage of hard macros and Develop reusable macros for system integration.
- CO3. Analyze verification methods at system level, block level and Hardware/Software Co-verification to reduce the test time.
- CO4. Apply various communication architectures to design energy efficient systems.

#### **DETAILED SYLLABUS:**

#### **UNIT I– SYSTEM ON CHIP DESIGN PROCESS (08 Periods)**

A canonical SoC Design, SoC Design flow- waterfall vs spiral, top down vs Bottom up. Specification requirement, Types of Specification, System Design process, System level design issues - Soft IP Vs Hard IP, Design for timing closure - Logic design issues, Verification strategy, Onchip buses and interfaces, Design for Low Power, Manufacturing test strategies.

#### **UNIT II – MACRO DESIGN PROCESS (07 Periods)**

Overview of IP Design, planning and Specification, Macro Design and Verification, Soft Macro Productization, Developing hard macros - Design issues for hard macros, Model Development for Hard Macros. System Integration with reusable Macros.

#### **UNIT III – SoC VERIFICATION - I (12 Periods)**

Technology Challenges, Verification technology options, Verification methodology, Testbench Creation, Testbench Migration, Verification languages, Verification IP Reuse, Verification approaches, Verification and Device Test, Verification plans, Bluetooth SoC. System level verification – System Design, System Verification. Block level verification – IP Blocks, Block Details of Bluetooth SoC, Lint Checking, Formal Model Checking, Functional Verification/Simulation, Protocol Checking, Directed Random Testing, Code Coverage Analysis

#### **UNIT IV – SoC Verification - II (12 Periods)**

Hardware/Software Co-verification- HW/SW Co-verification Environment, Emulation, soft or virtual Prototypes, Co-verification, UART Co-verification, Rapid Prototype Systems, Software Testing. Static netlist verification, Physical Verification and Design Signoff, Introduction to VMM (Verification Methodology Manual), OVM(Open Verification Methodology) and UVM (Universal Verification Methodology).

## **UNIT V – DESIGN OF COMMUNICATION ARCHITECTURES FOR SoCs(06 Periods)**

On chip communication architectures, System level analysis for designing communication, Design space exploration, Adaptive communication architectures-Communication architecture tuners. Communication architectures for energy/battery efficient systems. Introduction to bus functional models and bus functional model based verification.

**Total Periods: 45**

***Topics for Self Study are provided in the Lesson Plan***

### **TEXT BOOKS:**

1. Michael Keating, Pierre Bricaud, "Reuse Methodology manual for System On A Chip Designs", Kluwer Academic Publishers, Springer US, 3<sup>rd</sup> Edition, 2007.
2. Prakash Rashinkar, Peter Paterson and Leena Singh, "SoC Verification Methodology and Techniques", Kluwer Academic Publishers, Springer US, 2013.
3. A.A. Jerraya, W.Wolf, "Multiprocessor Systems-on-chips", M K Publishers, Elsevier Science, 2005.

### **REFERENCE BOOKS:**

1. William K. Lam, "Hardware Design Verification: Simulation and Formal Method based Approaches", Prentice Hall, 1st Edition, 2005.
2. Farzed Nekoogar, Faranak Nekoogar, "From ASICs to SOCs: A Practical Approach", China Machine Press, 2006.

## IV B. Tech. – I Semester

### (19BM70431) EMBEDDED SYSTEMS LAB

Int. Marks	Ext. Marks	Total Marks	L	T	P	C
40	60	100	-	-	2	1

**PRE-REQUISITES:** A Course on Microcontrollers.

**COURSE DESCRIPTION:** Familiarization using IDE – CCS, Energia; Instruction Set usage; GPIO – programming; Watchdog timer; Timer, ADC, Comparator – Programming; Low Power Modes demonstration; PWM generation – Speed Control of DC Motor; Networking MSPs.

#### **COURSE OUTCOMES:**

After successful completion of this course, the students will be able to:

- CO1. Analyze MSP430 Architecture, Instruction Set and Demonstrate Competence in developing programs using Assembly and Embedded C.
- CO2. Solve various Problems using CCS and Energia IDE effectively by evaluating various on-chip resources.
- CO3. Develop programs to realize control applications such as Speed control of DC Motor, Reading Ambient Temperature by investigating various interfacing techniques.
- CO4. Survey usage of MSP430 for Mixed Signal Processing and IOT Applications to establish communication deploying various protocols.
- CO5. Work independently and in teams to solve problems with effective Communication.

#### **LIST OF EXERCISES/LIST OF EXPERIMENTS:**

*(Minimum Ten Experiments to be done)*

1. Introduction to MSP430 launch pad and Programming Environment.
2. Practice on usage of Instruction Set
3. Read input from switch and Automatic control/flash LED (software delay).
4. Interrupts programming example using GPIO.
5. Configure watchdog timer in watchdog & interval mode.
6. Configure timer block for signal generation (with given frequency).
7. Read Temperature of MSP430 with the help of ADC.
8. Test various Power Down modes in MSP430.
9. Generation of Pulse Width Modulation.
10. Use Comparator to compare the signal threshold level.
11. Speed Control of DC Motor
12. Master slave communication between MSPs using SPI.
13. Networking MSPs using Wi-Fi.

#### **REFERENCE BOOKS/LABORATORY MANUALS:**

1. John H Davies, *MSP430 Microcontrollers Basics*, Newnes Publishers, 1<sup>st</sup>Edition, 2008.
2. C P Ravikumar, *MSP430 Microcontrollers in Embedded System Projects*, Elite Publishing House , 1<sup>st</sup>Edition, 2012.

#### **SOFTWARE/Tools used:**

Code Composer Studio Version 6, Energia, MSP430 launch pads, Wi-Fi booster pack.



**MINOR DEGREE IN**  
**POWER SYSTEMS AND DRIVES**

**Offering Department:** ELECTRICAL AND ELECTRONICS ENGINEERING

**Students of Eligible Branches:** CSE, CSSE, IT, ECE, EIE, ME and CE

**COURSE STRUCTURE**

Year & Semester	Course Code	Course Title	Contact Periods per week				Credits (C)	Scheme of Examination Max. Marks		
			L	T	P	Total		Int. Marks	Ext. Marks	Total Marks
III B.Tech. I-Sem  (2 Theory + 1 Lab)	19BM50201	Electrical Engineering Materials	3	-	-	3	3	40	60	100
	19BM50202	Electricity Safety and Practices	3	-	-	3	3	40	60	100
	19BM50203	Sustainable Energy Resources	3	-	-	3	3	40	60	100
	19BM50231	Electrical Workshop Practice	-	-	2	2	1	50	50	100
III B.Tech. II-Sem  (2 Theory + 1 Lab)	19BM60201	Principles of Energy Auditing and Conservation	3	-	-	3	3	40	60	100
	19BM60202	Special Machines and their Controllers	3	-	-	3	3	40	60	100
	19BM60203	Utilization of Electrical Energy	3	-	-	3	3	40	60	100
	19BM60231	Auditing and Conservation Practice lab	-	-	2	2	1	50	50	100
IV B.Tech. I-Sem  (1 Theory + 1 Lab)	19BM70201	Power Electronic Converters	3	-	-	3	3	40	60	100
	19BM70202	Fundamentals of Electric Vehicles	3	-	-	3	3	40	60	100
	19BM70203	Protection of Electrical systems	3	-	-	3	3	40	60	100
	19BM70231	Simulation of Electrical Systems lab	-	-	2	2	1	50	50	100

**Note:** If any student has chosen a course from the above list in their regular curriculum then, he/she is not eligible to opt the same course/s for the Minor degree. It is the responsibility of the student to acquire/complete prerequisite before taking the respective course.

### III B. Tech. – I Semester

#### (19BM50201) ELECTRICAL ENGINEERING MATERIALS

Int. Marks	Ext. Marks	Total Marks	L	T	P	C
40	60	100	3	-	-	3

**PRE-REQUISITES:** A course on Basic Electrical and Electronics Engineering.

**COURSE DESCRIPTION:** Dielectric properties of organic and inorganic materials and their required properties; Dielectric properties of insulators in static fields and alternating fields; Breakdown of dielectric materials in presence of high voltages; polymer insulation materials and their behaviour in presence of High voltages; Applications of various dielectric materials in high voltage equipment.

**COURSE OUTCOMES:** After successful completion of the course, students will be able to

- CO1. understand the dielectric properties of various organic and inorganic materials and their suitability for high voltage applications.
- CO2. realize the behavior of dielectric materials in the presence of static and in alternating fields.
- CO3. understand the breakdown mechanism of various dielectric materials in the presence of high voltages.
- CO4. realize the various polymer type insulation system for high voltage applications and the breakdown mechanism in composite insulation system.
- CO5. understand the suitability of various dielectric materials for various high voltage equipment.

#### **DETAILED SYLLABUS:**

##### **UNIT-I: CONDUCTING AND SEMICONDUCTOR MATERIALS (07 Periods)**

Ohms law and relaxation time of electrons, Electron scattering and resistivity of metals, thermal conductivity of metals, superconductivity; classification of semiconductors, Energy gap, conductivity in intrinsic semiconductors, Hall Effect and carrier density.

##### **UNIT-II: DIELECTRIC PROPERTIES OF INSULATORS IN STATIC FIELDS AND ALTERNATING FIELDS (08 Periods)**

Dielectric Properties of Insulating Materials, Various Types of Polarization in Dielectrics; Static dielectric constant, Polarization and dielectric constant, Internal fields in solids and liquids, static dielectric constant of solids, spontaneous polarization; Frequency dependency of polarization, Ionic polarization, complex dielectric constant, dipolar relaxation, dielectric losses.

##### **UNIT-III: BREAKDOWN PHENOMENA OF DIELECTRIC MATERIALS (12 Periods)**

**BREAKDOWN IN GASES**— Townsend's theory, Streamer's theory, breakdown in electro negative gases, Paschen's law, time lags of breakdown; insulation co-ordination.

**BREAKDOWN IN SOLID DIELECTRICS**— Thermal breakdown and electro mechanical breakdown, treeing and tracking, Internal discharges.

**BREAKDOWN IN LIQUID DIELECTRICS**— Suspended particle theory and stressed oil volume theory.

**UNIT-IV POLYMER AND COMPOSITE INSULATING MATERIALS (09 Periods)**

Polymeric Organic Materials, Thermoplastic Polymers, Thermoset Polymers, Polymer Compounds, Polyvinylchloride (PVC), Polyethylene (PE), Epoxy resins; Composite Insulating System—Impregnated Paper as a Composite Insulation System, Insulating Board Materials, Fiber Reinforced Plastics, Breakdown in composite insulators.

**UNIT-V: APPLICATIONS OF INSULATION MATERIALS (09 Periods)**

Applications in Power Transformers, Applications in Rotating Machines, Applications in Circuit Breakers, Applications in Cables, Applications in Power Capacitors, Applications in Electronic Equipment.

**Total Periods: 45**

***Topics for Self-study are provided in the Lesson Plan***

**TEXT BOOKS:**

1. Dekker, Adrianus J. *Electrical engineering materials*. Prentice-Hall, 1959.
2. Naidu MS. *High voltage engineering*. Tata McGraw-Hill Education; 2013 Jun 16.

**REFERENCE BOOKS:**

1. Arora, Ravindra, and Wolfgang Mosch. *High voltage and electrical insulation engineering*. Vol. 69. John Wiley & Sons, 2011.

### III B. Tech. – I Semester

#### (19BM50202) **ELECTRICITY SAFETY AND SAFE PRACTICES**

Int. Marks	Ext. Marks	Total Marks	L	T	P	C
40	60	100	3	-	-	3

**PRE-REQUISITES:** A course on Basic Electrical and Electronics Engineering.

**COURSE DESCRIPTION:** The course deals with the various aspects of potential risk due to electrical shock; safety precautions to be followed while working in hazardous zones; safe practices while handling various electrical equipment and during maintenance; and relevant electrical safety standards and Indian rules and acts.

**COURSE OUTCOMES:** After successful completion of the course, students will be able to:

- CO1. Understand the Indian electricity rules, regulations and various standards to be maintained for safety of life and equipment.
- CO2. Understand the potential effects of electrical shock and safety measures to protect against such risk.
- CO3. Understand the safety aspects and safe practices to be followed while installing residential, commercial and agricultural appliances.
- CO4. Identify various hazardous working zones and take necessary precautionary measures while working in such areas.
- CO5. Follow safety measures during installation, testing, commissioning and maintenance of electrical equipment/plant.

#### **DETAILED SYLLABUS:**

##### **UNIT-I: INDIAN ELECTRICITY RULES AND ACTS (09 Periods)**

OSHA standards of electrical safety, Basic electrical safety rules as per OSHA; Objectives and scope of IE acts and IE rules; Significance of Equipment earthing, Earthing of equipment bodies, structures and non-current carrying metallic parts, earthing of system neutral; Rules regarding first aid and firefighting facility, Electrical safety general requirements as per IE rules.

##### **UNIT-II: ELECTRICAL SAFETY AND SAFETY MANAGEMENT (10 Periods)**

**ELECTRIC SAFETY:** Terms and definitions, objectives of safety and security measures, Hazards associated with electric current and voltage, Protection against electrical hazards and types, Effect of current on human body, Principles of electrical safety and approach to prevent accidents.

**ELECTRIC SHOCKS AND ITS PREVENTION:** Primary and secondary electrical shocks, possibilities of getting electrical shock and its severity, medical analysis of electric shocks and its effects, shocks due to flash/ Spark over's, prevention of shocks, safety precautions against contact shocks, flash shocks, burns.

##### **UNIT-III: ELECTRICAL SAFETY IN RESIDENTIAL, COMMERCIAL AND AGRICULTURAL INSTALLATIONS (08 Periods)**

Introduction—Wiring and fitting; Domestic appliances—water tap giving shock, shock from wet wall, fan firing shock; Multi-storied building, Temporary installations,

Agricultural pump installation; Do's and Don'ts for safety in the use of domestic electrical appliances; Principles of safety management in electrical plants.

**UNIT-IV: ELECTRICAL SAFETY IN HAZARDOUS AREAS (08 Periods)**

Hazardous zones—class 0, 1 and 2; Sparks, flashovers and corona discharge in electrical plants; equipment for hazardous locations; Equipment/Enclosures for hazardous gases and vapours; Classification of Enclosures for hazardous locations; Explosives and provisions of Explosives Act.

**UNIT-V: SAFETY DURING INSTALLATION, TESTING AND MAINTENANCE (10 Periods)**

**Safety during installations:** Preliminary preparations, preconditions for start of installation work and safe sequence, safety aspects during installations.

**Safety during testing:** Purpose of commissioning checks and tests, equipment tests, high voltage energization tests, performance and acceptance tests, safety aspects during commissioning.

**Safety during maintenance:** Operators safety, Types of safety maintenance, Safety procedures, safety precautions during maintenance, planning of maintenance.

**Total Periods: 45**

**Topics for Self-study are provided in the Lesson Plan**

**TEXT BOOKS:**

1. S.Rao, Prof. H.L.Saluja, "Electrical Safety, Fire Safety Engineering and Safety Management", 2<sup>nd</sup> edition, Khanna Publishers. New Delhi, 2018 Reprint.

**REFERENCE BOOKS:**

1. Cadick, John, Mary Capelli-Schellpfeffer, and Dennis K. Neitzel. *Electrical safety handbook*. McGraw-Hill Education, 2012.

**ADDITIONAL LEARNING RESOURCES:**

**Indian Electricity acts:**

1. <https://cercind.gov.in/Act-with-amendment.pdf>
2. [https://www.indiacode.nic.in/handle/123456789/2058?view\\_type=browse&handle=123456789/1362](https://www.indiacode.nic.in/handle/123456789/2058?view_type=browse&handle=123456789/1362)

### III B. Tech. – I Semester

#### (19BM50203) SUSTAINABLE ENERGY RESOURCES

Int. Marks	Ext. Marks	Total Marks	L	T	P	C
40	60	100	3	-	-	3

**PRE-REQUISITES:** Course on Basic Electrical and Electronic Engineering

**COURSE DESCRIPTION:** Concepts of non-conventional and hybrid energy systems; Operational modes of Co-generation and their economic benefits.

**COURSEOUTCOMES:** After successful completion of the course, students will be able to:

- CO1. Understand the impacts of conventional energy resources on environment and realize various measures to minimize the greenhouse gas effects.
- CO2. Understand the generating principles and operational aspects of energy from solar.
- CO3. Understand the generating principles and operational aspects of wind energy conversion technologies.
- CO4. Understand the generating principles and operational aspects of Ocean energy, Biomass and geothermal energy conversion technologies.
- CO5. Assess the energy harnessing methods and develop a hybrid energy and energy storage systems.

#### **DETAILED SYLLABUS:**

#### **UNIT-I: ENVIRONMENTAL ASPECTS OF POWER GENERATION FROM CONVENTIONAL SOURCES (07 Periods)**

Impact of conventional sources on Environment; Limitation of fossil fuels – effects of hydro-electric projects - Atmospheric pollution – Green House Gases (GHG) emission from various energy sources and its effects – disposal of nuclear waste— need for renewable energy sources.

#### **UNIT-II: ENERGY FROM SOLAR (11 Periods)**

Introduction, solar radiation, measurement of solar radiation—pyranometer; solar energy collectors; flat plate collectors— liquid and air (non-porous) types; Focusing type— parabolic & point types; solar photovoltaic system— PV cell and its types, configuration of solar panel, PV system; Applications: solar pump, solar water heater.

#### **UNIT-III: ENERGY FROM WIND (08 Periods)**

Introduction, power extraction from the wind, Wind turbines— horizontal axis wind turbine—propeller type and vertical axis wind turbine— darrieus rotor type; basic components of wind energy conversion systems, Applications: energy storage, water pumping; environmental impacts.

#### **UNIT-IV: ENERGY FROM OCEAN, BIOMASS AND GEOTHERMAL RESOURCES (11 Periods)**

**Energy from ocean:** Introduction, ocean thermal energy conversion (OTEC): open and closed cycle power plants; tidal energy: schematic diagram of tidal power plant; advantages and disadvantages.

**Energy from Biomass:** Introduction, biomass conversion technologies-direct, thermochemical and biochemical conversions; biogas generation—anaerobic digestion process.

**Geothermal energy:** Introduction, Geothermal resources, geothermal power plants—vapor dominated and liquid dominated; environmental issues.

**UNIT-V: COGENERATION AND HYBRID ENERGY SYSTEMS (08 Periods)**

**Cogeneration-** Electricity generating systems, Economic and Environmental benefits. Operational modes of co-generation.

**Hybrid energy systems:** Need for hybrid systems, configuration and coordination, Block diagram approach of Stand-alone PV-wind system, PV-Diesel and Wind-diesel; energy storage systems — ultra capacitors, SMES.

**Total Periods: 45**

**Topics for Self-study are provided in the Lesson Plan**

**TEXT BOOKS:**

1. Rai, G.D., *Non-conventional Energy Sources*, Khanna Publishers, New Delhi, 2017.
2. S.Rao, Dr.B.B.Parulekar, *Energy Technology*, third edition, Khanna publications, 2013.

**REFERENCE BOOKS:**

1. J K Kaldellis, *Stand-alone and Hybrid Wind Energy Systems*, Wood head, publishing, 1<sup>st</sup> Edition 2010.
2. David Flin, *Cogeneration: A User's Guide*. Renewable energy series, Vol. 11. IET, 2010.
3. D P Kothari, K C Singal and Rakesh Ranjan, 'Renewable Energy Sources and Emerging Technologies' 2nd Edition, 2012.
4. S N Bhadra, D Kastha and S Banerjee, 'Wind Electric Systems', Oxford Publications, 2nd Edition, 2007
5. C S Solanki, 'Solar Photo-voltaics – Fundamentals, Technologies and Applications', PHI Pvt.,Ltd., 2nd Edition, 2011.
6. R. K. Rajput, *A textbook of power system engineering*, Laxmi publications (P) Ltd, 2016.

### III B.Tech. – I Semester

#### (19BM50231) ELECTRICAL WORKSHOP PRACTICE

Int. Marks	Ext. Marks	Total Marks	L	T	P	C
50	50	100	-	-	2	1

**PRE-REQUISITES:** A Course on Basic Electrical and Electronic Engineering

**COURSE DESCRIPTION:** Exercises on assessing of electrical parameters and functionality of electrical apparatus; Design and estimation of electrical systems, and protection system for electrical devices and systems; Troubleshooting of electrical appliances and calibration of measuring instruments.

**COURSE OUTCOMES:** After successful completion of the course, students will be able to:

- CO1 Demonstrate the usage of power tools for installation applications and cable laying with relevant accessories.
- CO2 Install panel boards for domestic/industrial applications, design and estimate wiring requirements following the code of conduct.
- CO3 Practice the measurement of electrical quantities using modern day tools and also calibrate the precession of the measuring instruments.
- CO4 Realize the protection equipment used in domestic/industry and practice protection schemes for a particular application.
- CO5 Demonstrate the practice of using various ancillary equipment for electrical appliances and also troubleshoot in the case of malfunctioning of electrical appliances.
- CO6 Work independently or in teams to solve problems with effective communication.

**List of Exercises/List of Experiments:**

*(Minimum **Ten** experiments are to be conducted)*

1. Identification and usage of hand and power tools, PPE for electrical installation applications.
2. Practice of cable laying and termination using conduits, casings, cable joints and its necessary items.
3. Installation and testing of single/three phase distribution boards for domestic/industrial applications.
4. Design and estimation of wiring for a typical house.
5. Measurement of electrical quantities using analog and digital meters.
6. Practice energy meter for measurement of energy and tariff estimation.
7. Calibration of measuring instruments.
8. Operation and testing of Fuse, MCB and Relays.
9. Measurement of equipment to earth resistance and determine the internal leakage currents.
10. Practicing and testing of DOL starter for Induction Motors.
11. Design of Timers for operation of electrical appliances.
12. Troubleshooting of electrical appliances — Fan, Mixer/grinder, Water heater/Iron box.



**REFERENCE BOOKS/LABORATORY MANUALS:**

1. <http://www.srisaiuniversity.org/downloads/files/n59b79d6117211.pdf>
2. [https://www.gtu.ac.in/syllabus/NEW\\_Diploma/sem-1/Pdf%20Content%20detailing/3312401Electrical%20&%20Electronic%20Workshop.pdf](https://www.gtu.ac.in/syllabus/NEW_Diploma/sem-1/Pdf%20Content%20detailing/3312401Electrical%20&%20Electronic%20Workshop.pdf)

**ADDITIONAL LEARNING RESOURCES:**

1. <https://www.youtube.com/watch?v=ax-KUL17YJ4>
2. <https://www.youtube.com/watch?v=TJpQ3fZIt20>
3. <https://www.youtube.com/watch?v=6RJnsa83xTA>
4. <https://www.youtube.com/watch?v=w2M4tS2OMsU>
5. <https://www.youtube.com/watch?v=DzVJiSQNbew>

### III B. Tech. – II Semester

#### (19BM60201) PRINCIPLES OF ENERGY AUDITING AND CONSERVATION

Int. Marks	Ext. Marks	Total Marks	L	T	P	C
40	60	100	3	-	-	3

**PRE-REQUISITES:** A Course on Basic Electrical and Electronics Engineering.

**COURSE DESCRIPTION:** Principles of energy audit, management and conservation; Energy efficient motors, lighting schemes; Energy measuring instruments and significance of energy economics.

**COURSE OUTCOMES:** After successful completion of this course, student will be able to:

- CO1. Apply the relevant rules, regulations and procedure of energy audit in industries and realize the energy management principles and protocols for effective conservation of energy.
- CO2. Analyze performance of energy efficient motors and illumination system by applying the relevant protocols of energy auditing.
- CO3. Apply appropriate energy auditing instruments for energy auditing in industries and assess their economic benefits.
- CO4. Apply the demand side management techniques and relevant standards for organization of energy conservation awareness programs.

#### DETAILED SYLLABUS:

##### UNIT-I: ENERGY AUDIT AND MANAGEMENT PRINCIPLES (10 periods)

Energy audit – definitions, concept, types of audit, energy index-cost index, pie charts, Sankey diagrams, load profiles, energy saving potential, energy audit of process industry, building energy audit. IE rules and regulations for energy audit.

Energy management – Principles of energy management, organizing energy management program, initiating, planning, controlling, promoting, monitoring, reporting.

##### UNIT-II: ENERGY CONSERVATION PRINCIPLES (08 Periods)

Energy scenario in India and world; Rules for efficient energy conservation; Technologies for energy conservation; Principles of energy conservation, roles and responsibilities of energy managers and auditors in industries.

##### UNIT-III: ENERGY EFFICIENT MOTORS AND LIGHTING (09 Periods)

**Energy efficient motors** - factors affecting efficiency, loss distribution, constructional details, characteristics, variable speed, variable duty cycle systems.

**Lighting** - Good lighting system, lighting control, lighting energy audit.

##### UNIT-IV: ENERGY INSTRUMENTS AND ECONOMIC ANALYSIS (10 periods)

Principles of energy instruments— Infrared thermometer, data loggers, thermo-couples, pyrometers, Lux meters, tongue testers, power quality analyzer, and PLC and pic applications.

Principles of Energy Economic Analysis— The time value of money concept. Cash flow models, payback analysis, depreciation—numerical problems.

## **UNIT-V: PRINCIPLES OF DEMAND SIDE MANAGEMENT (08 periods)**

Introduction to DSM, Principles of DSM, benefits of DSM, different techniques of DSM – time of day pricing; Management and organization of energy conservation awareness programs.

**Total Periods: 45**

**Topics for Self-study are provided in the Lesson Plan**

### **REFERENCE BOOKS:**

1. W.R. Murphy & G. McKay Butter worth, *Energy management*, Butter worth-Heinemann publications, 2<sup>nd</sup> edition, 2016.
2. Albert Thumann, William J. Younger, *Handbook of energy audits*, Taylor & Francis Ltd, 7<sup>th</sup> edition, 2008.
3. UmeshRathore, *Energy management*, S.K. Kataria & Sons, 2<sup>nd</sup> edition, 2014.
4. W.C. Turner, Stevedoty, *Energy management hand book*, CRC press, 6<sup>th</sup> edition, 2006.
5. D.P. Sen, K.R. Padiyar, Indrane Sen, M.A. Pai, *Recent Advances in Control and Management of Energy Systems*, Interline Publisher, Bangalore, 1993.
6. Ashok V. Desai, Wiley Eastern, *Energy Demand - Analysis, Management and Conservation Hand book on energy auditing - TERI (Tata Energy Research Institute)*, 2005.
7. Craig B. Smith, Kelly E. Parmenter, *Energy management principles Applications*, benefits, Savings, Elsevier Inc (Pergamon Press), 1<sup>st</sup> edition, 2016.

### **ADDITIONAL LEARNING RESOURCES:**

1. <https://beeindia.gov.in/sites/default/files/1Ch3.pdf>
2. <https://www.youtube.com/watch?v=M1zijCmeXJg>
3. <https://www.youtube.com/watch?v=FTpMWXMBSyM>
4. [https://www.youtube.com/watch?v=T1Au\\_P5bnQ](https://www.youtube.com/watch?v=T1Au_P5bnQ)
5. <https://www.youtube.com/watch?v=ENLzwTVjxms>
6. <https://www.youtube.com/watch?v=7hDyLuFJ0c8>
7. <https://www.youtube.com/watch?v=lkNIuFkzxBk>

### **USEFUL WEBSITES:**

1. <https://beeindia.gov.in/news-events/energy-conservation-building-code-rules-2018>
2. <https://beeindia.gov.in/content/energy-auditors>
3. <https://nayaenergy.com/difference-between-energy-audit-and-energy-management/>
4. <https://www.sgsgroup.in/en-gb/sustainability/environment/energy-services/energy-audits-and-management/energy-audit>
5. <https://www.consultivo.in/environment-energy/energy-audit-and-management/>
6. <https://www.teriin.org/energy>
7. <http://jnujprdistance.com/assets/lms/LMS%20JNU/Dual%20Degree%20Courses/PGD+MBA%20%20Energy%20Management/Sem%20III/General%20Aspects%20of%20Energy%20Management%20and%20Energy%20Audit.pdf>

### III B. Tech. – II Semester

#### (19BM60202) SPECIAL MACHINES AND THEIR CONTROLLERS

Int. Marks	Ext. Marks	Total Marks	L	T	P	C
40	60	100	3	-	-	3

#### PRE-REQUISITES: -

**COURSE DESCRIPTION:** Construction, Working, Types, control operation, characteristics and applications of Stepper Motors, Switched Reluctance Motors, Synchronous Reluctance Motors, Permanent Magnet Brushless DC Motors and Linear Induction Motors.

**COURSE OUTCOMES:** After successful completion of the course, students will be able to:

- CO1. Analyze the open and closed loop operational characteristics of stepper motor and assess its performance under various scenarios.
- CO2. Analyse the operational aspects of switched reluctance motor to assess the performance and design the constructional features for sustainability.
- CO3. Analyse the operational aspects of synchronous reluctance motor to assess its performance, sustainability and applications.
- CO4. Analyse the sensorless and sensor based operation and control aspects of permanent magnet brushless DC motor and assess the performance under diverse scenarios.
- CO5. Analyze the operational and control aspects of linear induction motor and assess their performance for special applications.

#### DETAILED SYLLABUS:

##### UNIT-I: STEPPER MOTORS (9 Periods)

Constructional features, types, working principle, torque equation, characteristics, open loop and closed loop control of stepper motor, applications.

##### UNIT-II: SWITCHED RELUCTANCE MOTORS (9 Periods)

Construction details, principle of operation, design of stator and rotor pole arcs, torque equation, characteristics, power converters, torque equations, control of switched reluctance motor and applications.

##### UNIT-III: SYNCHRONOUS RELUCTANCE MOTORS (9 Periods)

Constructional features, Types – Axial and Radial flux motors. Principle of operation, characteristics, phasor diagram, control of SyRM, advantages and applications.

##### UNIT-IV: PERMANENT MAGNET BRUSHLESS DC MOTOR (9 Periods)

Constructional details, principle of operation, types of BLDC motor, sensorless and sensor based control of BLDC motors, torque/speed characteristics and applications.

##### UNIT-V: LINEAR INDUCTION MOTOR (9 Periods)

Construction, principle of operation– single sided and double-sided LIM, thrust equations, performance equations based on current sheet concept, equivalent circuit, goodness factor, characteristics and applications.

**Topics for Self-study are provided in the Lesson Plan**

**TEXT BOOKS:**

1. K. VenkataRatnam, *Special Electrical Machines*, University press, New Delhi, 2009.
2. E.G. Janardhanan, *Special Electrical Machines*, PHI learning private limited, 2014.

**REFERENCE BOOKS:**

1. Takashi Kenjo, *Stepping Motors and their Microprocessor controls*, clarendon press, Oxford, 1984.
2. T.J.E. Miller, *Brushless Permanent Magnet and Reluctance Motor Drives*, clarendon press, Oxford 1989.
3. R. Krishnan, *Switched Reluctance Motor Drives – Modeling, Simulation, analysis, Design and Applications*, CRC press, Special Indian Edition, 2015.

### III B. Tech. –I Semester

#### (19BM60203) UTILIZATION OF ELECTRICAL ENERGY

Int. Marks	Ext. Marks	Total Marks	L	T	P	C
40	60	100	3	-	-	3

**PRE-REQUISITES:** A Course on Basic Electrical and Electronics Engineering.

**COURSE DESCRIPTION:** Types and characteristics of electric drives; types of electric heating and welding; Fundamentals and various methods of Illumination; electric traction; electrolysis, Extraction and refining of metals.

**COURSE OUTCOMES:** After successful completion of this course, student will be able to:

- CO1. Understand the operational aspects of various drives and apply an appropriate electric drives for various industrial applications.
- CO2. Understand the different types of heating and welding techniques.
- CO3. Design illumination system for proper lighting system under given circumstances.
- CO4. Understand the basic principle of traction systems and different braking techniques used in electric traction.
- CO5. Understand the basic principle and applications of electrolytic process.

#### **DETAILED SYLLABUS:**

##### **UNIT-I: ELECTRIC DRIVES (8 periods)**

Type of electric drives – rating and choice of motor - starting and running characteristics - particular applications of electric drives - types of industrial loads - Continuous - intermittent and variable loads.

##### **UNIT-II: ELECTRIC HEATING & WELDING (10 periods)**

**Introduction** - Advantages and methods of electric heating - resistance heating - induction heating and dielectric heating.

**Electric welding:** Classification- resistance and arc welding - electric welding equipment - comparison between AC and DC Welding.

##### **UNIT-III: ILLUMINATION (10 periods)**

Introduction - terms used in illumination - laws of illumination - sources of light. Discharge lamps – mercury vapor and sodium vapor lamps – comparison between tungsten filament lamps and fluorescent tubes – compact fluorescent lamp – LED -Basic principles of light control - Types and design of good lighting system and practice - flood lighting.

##### **UNIT-IV: ELECTRIC TRACTION (10 periods)**

Traction systems: System of electric traction and track electrification - Review of existing electric traction systems in India - Special features of traction motor - Speed-time curves for different services - methods of electric braking - plugging - rheostatic braking, regenerative braking.

**UNIT-V: ELECTROLYTIC PROCESS****(7 periods)**

Introduction - Basic principles - Faradays laws of electrolysis - Energy efficiency - Electrodeposition-Factors governing deposition Processes - Deposition of Alloys - Extraction and refining of metals.

**Total Periods: 45**

**Topics for Self-study are provided in the Lesson Plan:**

**TEXT BOOKS:**

1. C.L Wadhwa, *Generation Distribution and Utilization of Electrical Energy*, New age International Publishers,
2. J. B. Gupta, *Utilization of Electrical Power and Electric Traction*, S. K. Kataria and ons, 2002.

**REFERENCE BOOKS:**

1. N. V. Suryanarayana, *Utilization of Electrical Power including Electric drives and Electric traction*, New Age International (P) Limited, Publishers, 1996.
2. Alan.V. Oppenheim, Ronald.W. Schafer, John R Buck, *Discrete Time Signal Processing*, Prentice Hall, 2<sup>nd</sup>edition, 2006. E.Openshaw Taylor, *Utilization of Electric Energy*,Orient Longman,1971.

**ADDITIONAL LEARNING RESOURCES:**

1. <https://www.NPTEL> video lectures.
2. <https://www.opto-e.com/basics/led-pulsing-and-strobing>

### III B. Tech. – II Semester

#### (19BM60231) **AUDITING AND CONSERVATION PRACTICE LAB**

Int. Marks	Ext. Marks	Total Marks	L	T	P	C
50	50	100	-	-	2	1

#### **PRE-REQUISITES: -**

**COURSE DESCRIPTION:** Experimental investigations on behavior of insulators, performance of synchronous and asynchronous machines, relay testing and fault analysis.

**COURSE OUTCOMES:** On successful completion of the course, student will be able to:

- CO1. Demonstrate skill in identifying an appropriate auditing tool for measuring appropriate electrical and non-electrical preliminary quantities for auditing.
- CO2. Demonstrate skills to apply the auditing principles for illumination, house hold utilities and suggest a suitable conservation methods for economic benefits.
- CO3. Demonstrate skills to audit various industrial drives and suggest suitable methods for energy conservation adhering the protocols of auditing.
- CO4. Perform auditing by following the auditing protocols in various commercial, agricultural and domestic class of customers and suggest an appropriate energy conservation practices for economical benefits.
- CO5. Work independently or in teams to solve problems with effective communication.

#### **Practical Exercises/List of Experiments:**

*(Minimum Ten experiments are to be conducted.)*

1. Demonstration of auditing instruments for measuring electrical and non-electrical quantities for auditing purpose.
2. Measurement of active, reactive power and energy for auditing purpose.
3. Assess power quality problems using power quality analyzer and suggest a suitable conservative measures to mitigate.
4. Testing of Electric motor drive for energy conservation.
5. Analyze star labeled electrical apparatus and compare the data sheet of various star ratings.
6. Determine energy consumption by fluorescent/incandescent lamp and evaluate net energy savings and payback period by replacing with energy efficient lamp.
7. Evaluate energy conservation in a ceiling fan with and without an electronic regulator.
8. Conserve the energy consumption in a three phase induction motor by applying an appropriate energy conservation method.
9. Determine the energy conservation in an induction motor operating in star and delta mode of operation.
10. Estimate energy and economic savings by improving power factor for a given class of consumer.
11. Estimate the economic benefits of improving load factor for a domestic consumer.
12. Audit the energy of a commercial consumer and suggest an appropriate energy conservation practice to reduce energy bill.



**ADDITIONAL LEARNING RESOURCES:**

1. <https://sites.google.com/a/venusict.org/energy-conservation-and-management/ntpl-video-links>
2. <https://nptel.ac.in/courses/108/105/108105058/>
3. [https://www.youtube.com/watch?v=Nd\\_EL\\_B3JBQ](https://www.youtube.com/watch?v=Nd_EL_B3JBQ)
4. <https://www.youtube.com/watch?v=lkNIuFkzxBk>
5. <https://www.youtube.com/watch?v=730netBSZKY>
6. [https://www.youtube.com/watch?v=R\\_FdTPbgzTs](https://www.youtube.com/watch?v=R_FdTPbgzTs)

## IV B. Tech. – I Semester

### (19BM70201) POWER ELECTRONIC CONVERTERS

Int. Marks	Ext. Marks	Total Marks	L	T	P	C
40	60	100	3	--	--	3

#### PRE-REQUISITES: -

**COURSE DESCRIPTION:** Switched mode power supplies; Silicon Controlled Rectifier — with and without isolation, single and multiple outputs; Single phase and three phase topologies; DC-DC converter; AC-AC converter and AC-DC converter; DC-AC converter.

**COURSE OUTCOMES:** After successful completion of the course, students will be able to:

- CO1. Demonstrate the knowledge on energy conversion of Switched mode power supplies, Matrix converter and soft switch converters.
- CO2. Analyze closed loop control and regulation of Switched mode dc power supplies based converter.
- CO3. Analyze AC-DC, AC-AC and DC-AC circuit operation and evaluate their output parameters by using different firing pulses.
- CO4. Analyze the Soft switching techniques of AC-DC, DC-DC and DC-AC converter circuits by using ZVS, ZCS and quasi resonance operation.

#### DETAILED SYLLABUS:

##### UNIT-I: SWITCHED MODE POWER SUPPLIES (11 Periods)

DC Power supplies and Classification; Switched mode dc power supplies - with and without isolation, single and multiple outputs; Closed loop control and regulation; Design examples on converter and closed loop performance.

##### UNIT-II: AC-DC CONVERTERS (11 Periods)

Switched mode AC-DC converters. Synchronous rectification - single and three phase topologies - switching techniques - high input power factor . Reduced input current harmonic distortion. improved efficiency with and without input-output isolation; Performance indices design examples.

##### UNIT-III: DC-AC CONVERTERS (07 Periods)

Multi-level Inversion - concept, classification of multilevel inverters, Principle of operation, main features and analysis of Diode clamped, Flying capacitor and cascaded multilevel inverters; Modulation schemes.

##### UNIT-IV: AC-AC CONVERTERS WITH AND WITHOUT DC LINK (07 Periods)

Matrix converters. Basic topology of matrix converter; Commutation – current path; Modulation techniques - scalar modulation, indirect modulation; Matrix converter as only AC-DC converter; AC-AC converter with DC link - topologies and operation - with and without resonance link - converter with dc link converter; Performance comparison with matrix converter with DC link converters.

**UNIT-V: SOFT-SWITCHING POWER CONVERTERS****(09 Periods)**

Elementary principles of Soft switching techniques: ZVS and ZCS; Performance comparison hard switched and soft switched converters— AC-DC converter, DC-DC converter, DC-AC converter; Resonant DC power supplies.

**Total Periods: 45****Topics for Self-study are provided in the Lesson Plan****TEXT BOOKS:**

1. M.H.Rashid, *Power Electronics Handbook*, Academic press, New york, 2000.
2. Fang Lin Luo and Fang Lin Luo, *Advanced DC/DC Converters*, CRC Press, NewYork, 2004.
3. Marian P.Kazmierkowski, R.Krishnan and Frede Blaabjerg, *Control in Power Electronics- Selected Problem*, Academic Press (Elsevier Science), 2002.

**REFERENCE BOOKS:**

1. Issa Batarseh, *Power Electronic Circuits*, John Wiley and Sons, Inc.2004
2. Frede Blaabjerg and Zhe Chen,*Power Electronics for Modern Wind Turbines*, Morgan & Claypool Publishers series, United States of America, 2006.
3. Krein Philip T, *Elements of Power Electronics*, Oxford University press, 2008
4. Agarwal ,*Power Electronics: Converters, Applications, and Design*, 3rd edition, Jai P, Prentice Hall,2000
5. L. Umanand, *Power Electronics: Essentials & Applications*, John Wiley and Sons,2009

**ADDITIONAL LEARNING RESOURCES:**

1. <https://nptel.ac.in/courses/108/102/108102145/>
2. <https://nptel.ac.in/courses/108/101/108101126/>
3. <https://nptel.ac.in/courses/108/101/108101038/>
4. <https://nptel.ac.in/courses/108/107/108107128/>

## IV B. Tech. – I Semester

### (19BM70202) FUNDAMENTALS OF ELECTRIC VEHICLES

Int. Marks	Ext. Marks	Total Marks	L	T	P	C
40	60	100	3	--	--	3

**PRE-REQUISITES:** A Course on Basic Electrical and Electronics Engineering.

**COURSE DESCRIPTION:** Transportation vehicles and their impact in society; Concept, configurations, principle, types and operation of Electric Vehicles (EV); Power Electronic converters in EVs; Different motor drives & energy storage and management technologies in EVs.

**COURSE OUTCOMES:** After successful completion of the course, students will be able to:

- CO1. Understand the principle of operation of electric, hybrid-electric vehicles and various emerging technological challenges while confronting the issues during transportation.
- CO2. Analyze the performance characteristics of various power converters operating in different modes to assess a suitable convertor and its control strategies for sustainability of electric vehicle.
- CO3. Analyze various propulsion motor drives operating in different modes for sustainability and to determine their performance/operational parameters of electric vehicle.
- CO4. Analyze various battery energy storage & management systems and assess their adaptability for sustainable performance of electric vehicle.

#### DETAILED SYLLABUS:

##### UNIT-I: INTRODUCTION TO EVS AND HEVS (10 Periods)

Environmental impact and history of modern transportation, , Electric Vehicles (EVs) – configurations, traction motor characteristics; Hybrid Electric Vehicles (HEVs) – concept and architectures; series and parallel HEVs – configuration, operation, advantages and disadvantages; HEVs – interdisciplinary nature, challenges and key technologies; Plug-in EV – concept and architectures.

##### UNIT-II: POWER ELECTRONICS IN EVs AND HEVs (08 Periods)

Power electronics – semiconductor devices and circuits used for control and distribution of electric power, AC-DC, DC-DC, DC-AC conversion, four quadrant operation of converters, Thermal Management of HEV power electronics.

##### UNIT-III: ELECTRIC PROPULSION SYSTEM (09 Periods)

Introduction, configuration and control – DC motor drives, Induction Motor drives, Permanent Magnet Motor drives and Switched Reluctance Motor drives and drive efficiency.

##### UNIT-IV: ENERGY STORAGE SYSTEMS (09 Periods)

Electrochemical Batteries – terminology, specific energy, specific power, energy efficiency in lead-acid batteries, nickel based batteries, lithium based batteries; Ultra-

capacitors — features, principle of operation and performance; High speed fly-wheels — operating principle, power capacity, fly-wheel technologies and hybrid energy storage systems; Fuel cell — principle of operation and performance.

#### **UNIT-V: ENERGY MANAGEMENT SYSTEM**

**(09 Periods)**

Energy Management Strategies, Concept of State of Charge (SoC) and State of Health (SoH), EV charging standards, concept of V2G, V2V, V2H — principle of operation (Block diagram approach only). Wireless Power Transfer — principle of operation (Block diagram approach only).

**Total Periods: 45**

***Topics for Self-study are provided in the Lesson Plan***

#### **TEXT BOOKS:**

1. K. T. Chau, *Electric Vehicle Machines and Drives, Design, Analysis and Application*, Wiley, 2015.
2. John G. Hayes, *Electric Powertrain*, Wiley, 2018.

#### **REFERENCE BOOKS:**

1. Iqbal Husain, *Electric and Hybrid Vehicles Design Fundamentals*, 2<sup>nd</sup> edition, CRC Press, 2011.
2. Jack Erjavec, *Hybrid, Electric & Fuel-Cell Vehicles*, 2<sup>nd</sup> edition, Delmar Cengage learning, 2013.
3. MehrdadEhsani, Yimin Gao and Ali Emadi, *Modern Electric, Hybrid Electric and Fuel Cell Vehicles*, 2<sup>nd</sup> edition, CRC Press, 2015.
4. Chris Mi, M. AbulMasrur, David WenzhongGao, *Hybrid Electric Vehicles Principles and Applications with Practical Perspectives*, Wiley, 2011.

#### **ADDITIONAL LEARNING RESOURCES:**

1. <https://nptel.ac.in/courses/108/102/108102121/>
2. [https://swayam.gov.in/nd1\\_noc20\\_ee18/preview](https://swayam.gov.in/nd1_noc20_ee18/preview)
3. <https://www.coursera.org/learn/electric-vehicles-mobility?#syllabus>

## IV B. Tech. – I Semester

### (19BM70203) PROTECTION OF ELECTRICAL SYSTEMS

Int. Marks	Ext. Marks	Total Marks	L	T	P	C
40	60	100	3	--	--	3

**PRE-REQUISITES:** A Course on Basic Electrical and Electronics Engineering

**COURSE DESCRIPTION:** Overview of protective schemes; fuses; circuit breakers; electromagnetic relays; protective schemes applied for various components under various operating conditions; different grounding schemes.

**COURSE OUTCOMES:** After successful completion of the course, students will be able to:

- CO1. Apply the conceptual knowledge of various fuses for secured operation of domestic and industrial appliances.
- CO2. Apply the conceptual knowledge of various circuit breakers for secured operation of power system network.
- CO3. Apply the conceptual knowledge of various relays for secured operation of power system network.
- CO4. Analyze various protection schemes for the protection of alternators, transformers and motors.
- CO5. Apply various neutral grounding methods and determine the system parameters for protection in power system.

#### DETAILED SYLLABUS:

##### UNIT-I: FUSES

**(6 periods)**

Necessity of power system protection; Types of fuses — low voltage fuse and high voltage fuse; Advantages and disadvantages; Important terms — Current rating of fuse element, fusing current, fusing factor, cut-off current, pre-arcing time, arcing time, breaking capacity; Application of fuse in residential and commercial loads.

##### UNIT-II: ELECTRICAL SWITCHGEAR

**(9 periods)**

Essential features of switchgear, switchgear components; Phenomenon of arc, arc voltage, recovery voltage, restriking voltage; Types of circuit breakers; Construction and principle of operation — minimum oil circuit breaker, air blast circuit breaker, vacuum circuit breaker and SF<sub>6</sub> circuit breaker, and their comparisons, advantages and disadvantages; Applications of circuit breakers, importance of rating of circuit breakers.

##### UNIT-III: PROTECTIVE RELAYS

**(8 periods)**

Fundamental requirements of protective relaying, classification of relays — electromagnetic attraction and induction type relays; Construction and working principle of induction type over current relays, differential relays and biased differential relays; Universal torque equation; Characteristics of overcurrent, differential relays; Importance of primary and backup protection, elementary principles of static relays and microprocessor based relays.

## **UNIT-IV: PROTECTION OF ALTERNATORS, TRANSFORMERS AND MOTORS**

**(11 periods)**

**Protection of alternators:** Various faults in alternators — failure of prime-mover, failure of field, overcurrent, overvoltage, unbalanced loading, stator winding faults, rotor winding faults; Rotor protection; Stator protection — restricted earth fault protection and internal fault protection.

**Transformer protection:** Internal and external faults; Percentage differential protection, Protection against internal faults – Buchholtz relay.

**Motor protection:** Various faults & abnormal operating conditions, protection in motors, thermal relays and protection of small and large induction motors.

## **UNIT-V: SUBSTATION PROTECTION**

**(11 periods)**

**Protection of feeders:** Protection of radial and ring main feeders using over current relays.

**Protection against over-voltages:** Causes of over voltages in power systems, protection against lightning over voltages — surge diverters and absorbers; Working and applications of sphere gap, horn gap and valve type of lightning arrestors.

**Neutral grounding:** Necessity of neutral grounding, effects of ungrounded neutral on system performance; Methods of neutral grounding — solid, resistance and reactance grounding—merits and demerits.

**Total Periods: 45**

**Topics for Self-study are provided in the Lesson Plan**

### **TEXT BOOKS:**

1. Sunil S. Rao, *Switchgear Protection and Power Systems (Theory, practice and Solved Problems)*, 13<sup>th</sup> edition, Khanna Publishers, New Delhi, 2013.
2. Rohit Mehta and V.K. Mehta *Principles of Power System*, 24<sup>th</sup> edition, S. Chand Publishing, 2010.

### **REFERENCE BOOKS:**

1. Badri Ram, D. N. Viswakarma, *Power system Protection and Switchgear*, 2<sup>nd</sup> edition, McGraw Hill education (India) Private Limited, New Delhi, 2011.
2. C. L. Wadhwa, *Electrical Power systems*, 7<sup>th</sup> edition, New Age International (P) Limited, Publishers, New Delhi, 2017.

### **ADDITIONAL LEARNING RESOURCES:**

1. <https://nptel.ac.in/courses/108/101/108101039/>
2. <https://lsin.panasonic.com/blog/understand-importance-switchgear-protection-devices/>
3. <https://www.eit.edu.au/courses/professional-certificate-of-competency-electrical-power-system-fundamentals/>
4. <https://electrical-engineering-portal.com/download-center/books-and-guides/relays/protection-fundamentals>
5. [https://www.youtube.com/watch?v=LAiBuu\\_nICI](https://www.youtube.com/watch?v=LAiBuu_nICI)

## IV B. Tech. – I Semester

### (19BM70231) SIMULATION OF ELECTRICAL SYSTEMS LAB

Int. Marks	Ext. Marks	Total Marks	L	T	P	C
40	60	100	3	--	--	3

**PRE-REQUISITES:** Course on Basic Electric and Electronics Engineering.

**COURSE DESCRIPTION:** Investigation of behavior/operational aspects of various electrical systems using simulation tools.

**COURSE OUTCOMES:** After successful completion of the course, students will be able to:

- CO1. Demonstrate generation of signals and perform basic operations on the signals
- CO2. Analyze various electric circuits operating under different scenarios.
- CO3. Investigate the time domain specifications of a electrical system and develop a controller to control the dynamics.
- CO4. Determine the operational aspects of various electrical machines
- CO5. Analyze the operation of power electronic circuits for different operating conditions
- CO6. Estimate the tariff for domestic load and also forecast the load from the time series data.
- CO7. Work independently or in teams to solve problems with effective communication.

#### **Practical Exercises/List of Experiments:**

*(Minimum Ten experiments are to be conducted.)*

1. Generation of continuous and discrete time signals.
2. Basic operations on continuous and discrete time signals — Time scaling and amplitude scaling.
3. Simulate Locus diagram for RL and RC circuits.
4. Determine maximum power transfer using Maximum power transfer theorem.
5. Determine time domain specifications of a transfer function.
6. PID controller for controlling time domain response.
7. Load characteristics of asynchronous machine.
8. Determination of transformer efficiency.
9. Simulation of Single-phase half and full controlled bridge converter with R and RL loads.
10. Simulation of step-down and step-up choppers.
11. Load forecasting using statistical methods.
12. Estimating load consumption and tariff for the domestic load profile.



## **MINOR DEGREE IN INSTRUMENTATION AND CONTROL ENGINEERING**

**Offering Department:** ELECTRONICS AND INSTRUMENTATION ENGINEERING

**Students of Eligible Branches:** CSE, CSSE, IT, ECE, EEE, ME and CE

### **COURSE STRUCTURE**

Year & Semester	Course code	Course title	Contact Periods per week				Scheme of Examination Max. Marks		
			L	T	P	C	Int. Marks	Ext. Marks	Total Marks
III B.Tech. I-Sem (2 Theory+ 1 Lab)	19BM51001	Electrical and Electronic Measurements	3	-	-	3	40	60	100
	19BM51002	Industrial Instrumentation	3	-	-	3	40	60	100
	19BM51003	Computer Control of Process	3	-	-	3	40	60	100
	19BM51031	Industrial Instrumentation lab	-	-	2	1	50	50	100
III B.Tech. II-Sem (2 Theory+ 1 Lab)	19BM61001	Aircraft Instrumentation	3	-	-	3	40	60	100
	19BM61002	Process Control Instrumentation	3	-	-	3	40	60	100
	19BM61003	Smart Sensors	3	-	-	3	40	60	100
	19BM61031	Process Control Lab	-	-	2	1	50	50	100
IV B.Tech. I-Sem (1 Theory+ 1 Lab)	19BM71001	Biomedical Instrumentation	3	-	-	3	40	60	100
	19BM71002	Programmable Logic Controllers	3	-	-	3	40	60	100
	19BM71031	Biomedical Instrumentation Lab	-	-	2	1	50	50	100

**Note:** If any student has chosen a course from the above list in their regular curriculum then, he/she is not eligible to opt the same course/s for the Minor degree. It is the responsibility of the student to acquire/complete prerequisite before taking the respective course.

### III B. Tech. – I Semester

#### (19BM51001) ELECTRICAL AND ELECTRONIC MEASUREMENTS

Int. Marks	Ext. Marks	Total Marks	L	T	P	C
40	60	100	3	-	-	3

#### PRE-REQUISITES: -

**COURSE DESCRIPTION:** Science of measurement; construction and principle of operation of ammeters, voltmeters, ohmmeters; potentiometers; power meter; power factor meter; energy meter; design of AC and DC bridges; frequency and time measurements.

**COURSE OUTCOMES:** After successful completion of the course, students will be able to:

- CO1. Select suitable measuring instrument for measurement of voltage, current, resistance, power and energy by applying the fundamental concepts of measuring instruments.
- CO2. Calibrate the DC and AC potentiometers and apply the concepts for calibration of ammeter & voltmeter and measurement of resistance & inductance.
- CO3. Design AC and DC bridges for measurement of resistance, capacitance and Inductance.
- CO4. Demonstrate the digital measuring instrument used for measurement of frequency and time period.

#### DETAILED SYLLABUS:

##### UNIT-I: AMMETERS AND VOLTMETERS

(11 Periods)

Classification of analog instruments, Principle of operation of analog instruments, operating forces of electromechanical indicating instruments: deflecting, control and damping; Permanent Magnet Moving Coil (PMMC): Construction, working principle, Expression of torque equation, Errors in PMMC Instruments, Advantage and Disadvantages of PMMC Instruments; Moving Iron Instruments: Classification of Moving Iron Instruments, Construction, working principle and Expression of torque equation; Ammeter: Ammeter shunt, Effect of Temperature Change in Ammeter, Multi-range Ammeters; Voltmeter: Voltmeter Multipliers, Effect of Temperature Change in Voltmeters, Multi-range Voltmeter Analog voltmeter, AC voltmeter using rectifiers, true RMS Voltmeter

##### UNIT-II: OHMMETERS AND POTENTIOMETERS

(9 Periods)

Ohmmeters: Series type ohmmeter, shunt type ohmmeter, Multimeter.

DC Potentiometers: Basic potentiometer circuit, standardization, Compton's Potentiometers, Multiple-range potentiometer, applications: Calibration of Voltmeter, Calibration of Ammeter, Measurement of Resistance.

AC Potentiometers: Standardization, Types of A.C Potentiometers: Polar types, Coordinate types, applications: Voltmeter Calibration, Ammeter Calibration, Measurement of Self reactance of a coil.

**UNIT-III: POWER & ENERGY METERS****(8 Periods)**

Power in D.C Circuits, Power in A.C Circuits, Electrodynamometer wattmeter: Construction, working principle, Torque equation, Errors in Electrodynamometer wattmeter, Three Phase Wattmeter. Electrodynamometer Power Factor Meter: Single Phase, Three Phase. Energy Meter: Single Phase Induction Type Energy Meter: Construction, Working Principle, Errors in Single Phase energy meter; Polyphase energy meters: Two element energy meter

**UNIT-IV: BRIDGES****(8 Periods)**

Measurement of Resistance: Medium Resistance Measurement: Wheatstone bridge, Kelvin Bridge; Low Resistance Measurement: Kelvin double bridge; High Resistance Measurement: Direct deflection methods.

Measurement of Inductance: Maxwell Bridge, Hay's Bridge and Anderson Bridge.

Measurement of capacitance: De Sauty's Bridge and Schering bridge, Q-meter.

**UNIT-V:FREQUENCY AND TIME MEASUREMENTS****(9 Periods)**

Digital Frequency Meter - Basic Circuit, Time Base Selector, Start and Stop gate; Circuit for Measurement of Frequency; Simplified Composite Circuit for a Digital Frequency Meter; High Frequency Measurement, Frequency synthesizer; Period Measurement; Ratio and Multiple Ratio Measurements; Time Interval Measurements; Universal Counter Timer.

**Total Periods: 45**

**Topics for self-study are provided in the lesson plan**

**TEXT BOOK:**

1. A.K.Sawhney, *A Course in Electrical and Electronics Measurements and Instrumentation*, Dhanpat Rai and Sons, New Delhi, 19<sup>th</sup> Revised edition, 2013.
2. H S Kalsi, *Electronic Instrumentation and Measurements*, McGraw-Hill, 4<sup>th</sup> edition, 2019.

**REFERENCE BOOKS:**

1. E.W. Golding & F.C. Widdis, *Electrical Measurements and Measuring Instruments*, 5<sup>th</sup> edition, Wheeler Publishing.
2. Doebelin, E.O., *Measurement Systems: Applications and Design*, McGraw-Hill, 4<sup>th</sup> edition 2003.

**ADDITIONAL LEARNING RESOURCES:**

1. <https://nptel.ac.in/courses/108/105/108105153/>
2. [https://swayam.gov.in/nd1\\_noc19\\_ee44/preview](https://swayam.gov.in/nd1_noc19_ee44/preview)

## IIIB. Tech. – I Semester

### (19BM51002)INDUSTRIAL INSTRUMENTATION

Int. Marks	Ext. Marks	Total Marks	L	T	P	C
40	60	100	3	-	-	3

#### **PRE-REQUISITES: -**

**COURSE DESCRIPTION:** Measurement of humidity, Viscosity, Density, Pressure, Level and Flow parameters; Signal Conditioning & Safety Instruments.

**COURSE OUTCOMES:** After successful completion of the course, students will be able to:

- CO1. Analyze and identify the appropriate transducer to measure density, viscosity, humidity and pressure based on applications.
- CO2. Analyze and identify the appropriate transducer to measure level and flow based on applications.
- CO3. Design signal conditioning circuit for amplifiers, range extension and conversion of V to I & I to V.
- CO4. Demonstrate the safety instruments, requirements for safety and standards.

#### **DETAILED SYLLABUS:**

#### **UNIT - I: DENSITY, VISCOSITY & HUMIDITY MEASUREMENT (11 Periods)**

Density: Introduction, Pressure head type, Displace type, Float type, Buoyancy effect densitometer method, Hot-wire gas bridge type, Vibration type, Radioactive method. Viscosity: Introduction, Friction tube viscometer, Saybolt's viscometer, Rotameter viscometer, Searle's rotating cylinder, Cone and Plate viscometer. Consistency meter – Rotating vane type and oscillating type. Humidity: Psychrometer, hygrometer & Types, Dew point device. Analysis and selection of Density, Viscosity and Humidity sensors.

#### **UNIT - II: PRESSURE MEASUREMENT (8 Periods)**

Dead weight gauges, Manometer and its Types, Elastic transducers – Bourdon tube, Diaphragm, Bellows, Electrical Types, Resistive, Inductive and Capacitive, Force balance & Vibrating Cylinder, High pressure measurement – Very high pressure transducer (Bulk modulus Gage), Low Pressure (Vacuum) measurement – McLeod Gage, Knudsen Gage, Momentum transfer gage, Thermal conductivity gage, Ionization gage, Sound level meter, Microphone. Analysis and selection of pressure sensors.

#### **UNIT – III: LEVEL MEASUREMENT (7 Periods)**

Introduction, Gauge Glass technique, Float Types – Float-and- tape method, Float-and-shaft method, Magnetic float types. Displacer types, Hydrostatic types – Air-Purge type, Bubbler type. Thermal effect types, Electrical types – Resistance switch type, Inductive and Capacitance type. Ultrasonic Methods, bellow element type level transmitters, Fibre - optic type, Analysis and selection of level sensors.

#### **UNIT – IV: FLOW MEASUREMENT**

**(10 Periods)**

Introduction, Head types – Orifice, Venturi, Flow Nozzle, Dahl Tube, Pitot tube, Area Flow meter - Rotameter & types, Mass flow meters – Turbine Mass flow meter, Coriolis flow meter, Gyroscopic flow meter, Liquid bridge mass flow meter, Calorimetric flow meter. Positive Displacement type flow meters - Nutating Disc, Rotary Vane, Lobed Impeller, Reciprocating Piston type, Fluted Rotor. Electrical type flow meter – Turbo magnetic flow meter, Electromagnetic flow meter, Ultrasonic flow meter, Hotwire anemometer type, Vertex Shedding type. Analysis and selection of Flow sensors.

#### **UNIT-V: SIGNAL CONDITIONING & SAFETY INSTRUMENTS**

**(9 Periods)**

Wheatstone bridge: Compensation & Sensitivity. Design of I to V, V to I converters, Range conversion of current, voltage, Design application of Instrumentation amplifier, Signal conditioning for Self-generating sensors: Chopper and low drift amplifiers Composite amplifier, charge amplifier and electrometer amplifier.

Proximity Sensors, Limit switches, Electrical & Intrinsic Safety: NEMA types, Fuses & Circuit breakers. Explosion hazards & intrinsic safety – Protection methods, Purging, pressurization, ventilation.

**Total Periods: 45**

***Topics for self-study are provided in the lesson plan***

#### **TEXT BOOKS:**

1. Patranabis, *Principles of Industrial Instrumentation*, TMH, 3rd Edition, 2010.
2. K. Sawhney, *A Course in Electrical and Electronics Measurements and Instrumentation*, Dhanpat Rai and Sons, 19th edition, 2011.

#### **REFERENCE BOOKS:**

1. Bela G Liptak, *Instrument Engineers' Handbook: Process Measurement and Analysis*, CRC Press - Butterworth Heinemann, 4th Edition, 2003.
2. Ramon PallásAreny, John G. Webster, *Sensors and Signal Conditioning*, John Wiley and Sons, 2nd Edition, 2000.
3. Ernest Doebelin, Dhanesh Manik, *Measurement Systems*, McGraw-Hill International, 6th Edition, 2011.

#### **ADDITIONAL LEARNING RESOURCES:**

1. <https://nptel.ac.in/courses/108105064/>
2. [https://nptel.ac.in/content/storage2/nptel\\_data3/html/mhrd/ict/text/108105064/lec1.pdf](https://nptel.ac.in/content/storage2/nptel_data3/html/mhrd/ict/text/108105064/lec1.pdf)
3. <https://www.ibiblio.org/kuphaldt/socratic/sinst/book/liii.pdf>

### III B. Tech. – I Semester

#### (19BM51003) COMPUTER CONTROL OF PROCESS

Int. Marks	Ext. Marks	Total Marks	L	T	P	C
40	60	100	3	-	-	3

#### PRE-REQUISITES: -

**COURSE DESCRIPTION:** Analysis of discrete state variable system identification techniques, direct discrete design techniques, advanced control strategies used in industries, Adaptive Control.

**COURSE OUTCOMES:** After successful completion of the course the student will be able to

- CO1. Demonstrate knowledge on discrete data systems, Z –Transform and modified Z - Transform of Sampled Data system.
- CO2. Design of controllers based on discrete time models are used in Industries.
- CO3. Analyze various control strategies and identify mathematical model for various systems.
- CO4. Asses the information to provide effective solution for real time problems using adaptive control methods.

#### DETAILED SYLLABUS:

##### UNIT-I: DISCRETE STATE-VARIABLE TECHNIQUE (11 Periods)

State equation of discrete data system with sample and hold, State transition equation, Methods Of computing the state transition matrix, Decomposition of discrete data transfer functions, State Diagrams of discrete data systems, System with zero-order hold, Controllability and observability of linear time invariant discrete data system, Stability tests of discrete-data system.

##### UNIT-II: SYSTEM IDENTIFICATION (8 Periods)

System Theory, Mathematical models, Model properties, Structural model representation, System identification procedure. Modified Z – Transform, First order system with time delay.

##### UNIT-III: DESIGN OF CONTROLLERS (9 Periods)

Computer control loop, Converting continuous time controller to discrete time domain, Design of controllers based on discrete time model beat and Dahlin's algorithms. Design of Feed Forward Controller: Block Diagram.

##### UNIT-IV: ADVANCED PROCESS CONTROL STRATEGIES (9 Periods)

Cascade Control- Dynamic response, Types, Implementation, Predictive Control- Model based and Multivariable System, Statistical Process Control. Algorithms for Processes with Dead Time – Smith Predictor, Analytical Predictor.

**UNIT-V: ADAPTIVE CONTROL****(8 Periods)**

Self-Tuning Regulators, Adaptive Control Adjustment, Indirect Adaptive Control, Direct Adaptive Control, Model Reference Adaptive Control, Relationship between MRAC and STR, Inertial Control with examples.

**Total Periods: 45****TEXT BOOKS:**

1. S.K.Singh, *Computer Aided Process Control*, PHI, 2009.
2. Gopal, M., *Digital Control and State Variable Methods*, Tata McGraw Hill, 2003.

**REFERENCE BOOKS:**

1. M. Chidambaram, *Computer Control of Processes*, Narosa Publications, 2nd Edition, 2003.
2. Karel J. Keesman, *System Identification: An Introduction*, Springer, 2011.
3. Pradeep B. Deshpande and Raymond H Ash, *Elements of Computer Process Control with Advanced Applications*, 2nd Edition, Instrument Society of America, 1981.
4. Krishna Kant, *Computer-based Industrial Control*, 2nd Edition, PHI, Delhi, 2010.

**ADDITIONAL LEARNING RESOURCES:**

1. <http://nptel.ac.in/courses/112103174/4>
2. <http://nptel.ac.in/courses/112103174/3>
3. [www.freevideolectures.com /Course/3126/Process-Control-and-Instrumentation](http://www.freevideolectures.com/Course/3126/Process-Control-and-Instrumentation)
4. [www.nptel.ac.in/courses/103105064/](http://www.nptel.ac.in/courses/103105064/)

## IIIB. Tech. – I Semester

### (19BM51031) INDUSTRIAL INSTRUMENTATION LAB

Int. Marks	Ext. Marks	Total Marks	L	T	P	C
50	50	100	-	-	2	1

**PRE-REQUISITES:** Course on Industrial Instrumentation

**COURSE DESCRIPTION:** LabVIEW basics; Circuit design and simulation in Multisim; Measurement of Torque, Temperature, Viscosity, Humidity, Pressure, Level and Flow.

**COURSE OUTCOMES:** After successful completion of the course, students will be able to:

- CO1. Apply the LabVIEW functions in programming.
- CO2. Simulate electrical circuits using Multisim.
- CO3. Analyze the characteristics of measuring instruments by applying the fundamental concepts.
- CO4. Develop PC based data logger systems by interfacing hardware devices like myRIO, ELVIS and required sensors for measurement.
- CO5. Design and solve problems in the measurement of parameters for required specifications.
- CO6. Work independently and in teams to solve problems with effective communication.

#### **LIST OF EXPERIMENTS:**

*(Minimum ELEVEN experiments are to be conducted)*

1. LabVIEW Basics : Practice of Virtual Instrumentation Course content  
Numeric, Boolean, Strings, For, While, Case Structures, Arrays, Clusters, Sequence: Flat, Stacked, Formula Node, SubVI's, Local/Global Variables.
2. Data Acquisition and analysis using Graphs, Charts, myRio/ELVIS and LabVIEW.
3. Data Logging and analysis of simulated or acquired signals using File I/O.
4. Design and verification of converters using op-amps in Multisim.
  - a) I to V
  - b) V to I
5. Design and verification of resistance measurement, conversion in Multisim using
  - a) Op-Amp
  - b) Wheatstone bridge for improving sensitivity, compensation and linearity.
6. Measurement of Pressure.



7. Measurement of Humidity.
8. Measurement of Flow.
9. Measurement of Torque.
10. Measurement of Viscosity.
11. Design and verification of level measurement.
12. Design and verification of Speed measurement.
13. Design and verification of temperature measurement using LabVIEW & ELVIS.

**REFERENCE BOOKS/LABORATORY MANUALS:**

1. Travis Jeffrey, Jim Kring, *LabVIEW for Everyone*, Pearson Education, 2009.
2. Johnson Jennings, *LabVIEW Graphical Programming*, McGraw Hill, 4<sup>th</sup> Edition, 2014.
3. D. Roy Chowdhury, *Linear Integrated Circuits*, New Age International Pvt. Ltd., 4th Edition, 2010.
4. D. Patranabis, *Principles of Industrial Instrumentation*, TMH, 3rd Edition, 2010.
5. Ramon PallásAreny, John G. Webster, *Sensors and Signal Conditioning*, John Wileyand Sons, 2nd Edition, 2000.
6. A. K. Sawhney, *A Course in Electrical and Electronics Measurements and Instrumentation*, Dhanpat Rai and Sons, 19th edition, 2011.

**SOFTWARE/Tools used:**

1. NI Labview 2018
2. NI Circuit Design Suite – Multisim 2019
3. NI myRIO
4. NI ELVIS

**ADDITIONAL LEARNING RESOURCES:**

1. <https://www.ni.com/pdf/manuals/320999e.pdf>
2. <https://ieeexplore.ieee.org/document/8960023/>  
A Different way of Level measurement for PBL in Education of Students using NI-LabVIEW, Multisim and MyRIO
3. <http://www.ni.com/pdf/manuals/376047c.pdf>
4. [https://www.clemson.edu/cecas/departments/ece/document\\_resource/undergrad/lab\\_manuals/NI\\_ELIVS\\_II\\_Orientation\\_Manual.pdf](https://www.clemson.edu/cecas/departments/ece/document_resource/undergrad/lab_manuals/NI_ELIVS_II_Orientation_Manual.pdf)
5. <http://www.ni.com/pdf/manuals/374629c.pdf>
6. <http://www.ni.com/pdf/manuals/373363f.pdf>

## IIIB. Tech. – II Semester

### (19BM61001) AIRCRAFT INSTRUMENTATION

Int. Marks	Ext. Marks	Total Marks	L	T	P	C
40	60	100	3	-	-	3

#### PRE-REQUISITES: -

**COURSE DESCRIPTION:** Aircraft Instruments; Air Data Instruments; Gyroscopic Instruments; Engine Instruments and Flight Control and Navigational Aids, EFIS, Electronic warfare and Aircraft safety.

**COURSE OUTCOMES:** After successful completion of the course, students will be able to:

- CO1: Demonstrate knowledge on aircraft system.
- CO2: Select suitable instrument for specific parameter measurement in an aircraft.
- CO3: Design control schemes for Auto pilot and Auto-throttle system in an aircraft.
- CO4: Select navigation aids for appropriate communication in an aircraft.
- CO5: Demonstrate knowledge on aircraft safety systems and electronic warfare.

#### DETAILED SYLLABUS:

##### UNIT-I: INTRODUCTION TO AIRCRAFT

(10 Periods)

Control Surfaces, Forces, Moments and Angle of Attack, Modern Aircraft System, Aircraft Instruments and their Layout, Aircraft Display Types: Quantitative Displays, Display Color and Markings, Glass Cockpits of Modern Aircraft: Attitude Director Indicator, Electronic Attitude Director Indicator, Horizontal Situation Indicator, EFIS, Command bars, HSI, ADP.

##### UNIT-II: COCKPIT INSTRUMENTS

(10 Periods)

Introduction to Air Data Instruments, Air Data Computer, Combined Pitot and Static Probe, Position Error, ASI, ALTI, VSI, Introduction to Gyro, Vibrating Gyros, Ring Laser Gyroscope, Fibre Optic Gyros, Directional Gyro, Gyro Horizon.

##### UNIT-III: ENGINE INSTRUMENTS

(10 Periods)

Introduction, Engine Speed Measurement: Electrical TachoGenerator/Indicator, Non-Contact type TachoProbe, Torque Measurement, Electronic Torque Meter, Pressure Measurement, Engine vibration Measurement and Monitoring, Fuel Flow Rate Indicator, Engine Fuel Quantity Indicator

**UNIT-IV: FLIGHT CONTROL AND NAVIGATIONAL AIDS****(8 Periods)**

Introduction to AFCS, Auto pilot, Auto-throttle, IFCS, Fundamentals of Radio Navigation Aids, VOR, DME, Instrument Landing system, GPS.

**UNIT-V: ELECTRONIC WARFARE AND AIRCRAFT SAFETY****(7 Periods)**

Introduction to Electronic warfare, Electronic support, EP, EA, Jamming and Spoofing, DEW, Air data warning systems, Stall warning systems, GPWS, TCAS

**Total Periods: 45**

**Topics for self-study are provided in the lesson plan**

**TEXT BOOK:**

1. S.Nagabhushana, L.K.Sudha, *Aircraft Instrumentation and Systems*, I K International Publishing House Pvt. Ltd, 2010

**REFERENCE BOOK:**

1. Pallett, E.H.J, *Aircraft Instruments and Integrated Systems*, Pearson higher Education, 1992.

**ADDITIONAL LEARNING RESOURCES:**

1. <https://nptel.ac.in/courses/101/104/101104069/>
2. <https://nptel.ac.in/courses/112/103/112103281/>
3. <http://www.nptelvideos.in/2012/11/space-flight-mechanics.html>

### III B. Tech. – II Semester

#### (19BM61002) PROCESS CONTROL INSTRUMENTATION

Int. Marks	Ext. Marks	Total Marks	L	T	P	C
40	60	100	3	-	-	3

#### PRE-REQUISITES: -

**COURSE DESCRIPTION:** Mathematical modeling of processes, Different types of controllers, characteristics of controllers, design of controllers, Tuning of controllers, characteristics of control valves, multi loop controllers.

**COURSE OUTCOMES:** After successful completion of the course, students will be able to:

- CO1. Develop mathematical model of various process by applying fundamental laws.
- CO2. Design controller by applying fundamental concepts of control schemes and tuning methods.
- CO3. Demonstrate knowledge on various final control elements used in process Industries
- CO4. Apply the Multi loop control concepts of real time industrial and domestic applications.

#### DETAILED SYLLABUS:

##### UNIT - I: PROCESS CHARACTERISTICS

(10 Periods)

Elements of process control, Process variables, Degree of freedom, Characteristics of electric system, liquid system, gas system and thermal system, Elements of process dynamics, Mathematical model of liquid process, gas process and thermal processes, Servo operation, Regulatory operation, Self-regulation.

##### UNIT - II: CONTROL SCHEMES AND CONTROLLERS

(10 Periods)

Discontinuous controller modes: Two position, Multi-position, Floating control modes; Continuous controller modes: Proportional, Integral, Derivative; Composite controller modes: PI, PD, PID; Electronic controllers: Design of discontinuous, continuous and composite controller modes. Pneumatic controllers (displacement type).

**UNIT – III: CONTROLLER TUNING****(8 Periods)**

One-Quarter decay ratio criteria, Time integral performance criteria, Process loop tuning: open-loop transient response method, Ziegler-Nichol's method, Cohen- Coon method, Direct synthesis method, Frequency response method.

**UNIT - IV: FINAL CONTROL ELEMENTS****(9 Periods)**

Pneumatic actuators: Spring actuator, Hydraulic actuators: Piston actuator, Electrical actuators: Solenoid, Electro-pneumatic actuators, Control valves: Types of control valves and its characteristics, Sliding-stem control valves, Rotating-shaft control valves, Selection of control valves, Control-valve sizing, Pneumatic valve positioner.

**UNIT - V: MULTI LOOP CONTROL SCHEMES****(8 Periods)**

Cascade control, Ratio control, Feed forward control, Over-ride, Split range, Case study on distillation column: Principle control scheme- constant top product, constant bottom product and reflux rate, constant reflux rate and steam rate.

**Total Periods: 45**

***Topics for self-study are provided in the lesson plan***

**TEXT BOOKS:**

1. Donald P. Eckman, *Automatic Process Control*, Wiley Eastern Ltd., 1993.
2. Curtis D. Johnson, *Process Control Instrumentation Technology*, Pearson Education, New Delhi, 7<sup>th</sup> Edition, 2002.
3. G. Stephanopoulos, *Chemical Process Control*, PrenticeHall, 1990.

**REFERENCE BOOKS:**

1. Patranabis, *Principles of Process Control*, TMH., 1981.
2. Peter Harriot, *Process Control*, TMH.
3. K. Krishnaswamy, *Process Control*, New Age International, 2<sup>nd</sup> Edition, 2009.

**ADDITIONAL LEARNING RESOURCES:**

1. <https://nptel.ac.in>
2. <https://www.amtekcompany.com> > Amatrol
3. <https://wiki.metakgp.org> > H31011:Instrumentation and Process Control

**III B. Tech. – II Semester**  
**(19BM61003) SMART SENSORS**

Int. Marks	Ext. Marks	Total Marks	L	T	P	C
40	60	100	3	-	-	3

**PRE-REQUISITES: -**

**COURSE DESCRIPTION:** Smart sensors for physical variables, Different smart materials and technologies, getting sensor information to MCU, Communication protocols and different standards for smart sensors.

**COURSE OUTCOMES:** After successful completion of the course, students will be able to:

- CO1. Apply suitable smart sensor for measurement of physical parameters.
- CO2. Demonstrate knowledge on smart materials and its fabrication techniques.
- CO3. Design signal conditioning circuits for various smart sensors.
- CO4. Select appropriate protocol for real time applications.
- CO5. Demonstrate knowledge on IEEE standards for smart sensors.

**DETAILED SYLLABUS:**

**UNIT-I: SMART SENSORS FOR ELECTRICAL AND NON-ELECTRICAL, PHYSICAL AND CHEMICAL VARIABLES: TENDENCIES AND PERSPECTIVES (8 Periods)**

Introduction, Temperature IC and Smart Sensors, Pressure IC and Smart Sensors and Accelerometers, Rotation Speed Sensors, Intelligent Opto Sensors, Humidity Frequency Output Sensors, Chemical and Gas Smart Sensors.

**UNIT-II: MATERIALS AND TECHNOLOGIES (9 Periods)**

Materials: Silicon as a Sensing Material, Plastics, Metals, Ceramics, Structural Glasses, Optical Glasses, Nano-materials, Surface Processing: Spin-Casting, Vacuum Deposition, Sputtering, Chemical Vapor Deposition, Electroplating, MEMS Technologies: Photolithography, Silicon Micromachining, Micromachining of Bridges and Cantilevers, Wafer Bonding.

**UNIT-III: GETTING SENSOR INFORMATION INTO THE MCU (10 Periods)**

Introduction, Amplification and Signal Conditioning: Instrumentation Amplifiers, SLEEP MODE Operational Amplifier, Rail-to-Rail Operational Simplifiers, Switched-Capacitor Amplifier, 4- to 20-mA Signal Transmitter, Inherent Power-Supply Rejection, Separate Versus Integrated Signal Conditioning: Integrated Passive

Elements, Integrated Active Elements, Digital Conversion: A/D Converters, Performance of A/D Converters, Implications of A/D Accuracy and Errors.

#### **UNIT-IV: COMMUNICATIONS FOR SMART SENSORS (9 Periods)**

Introduction, Sources (Organizations) and Standards, Automotive Protocols: CAN Protocol, LIN Protocol, Media Oriented Systems Transport, FlexRay, Industrial Networks, Protocols in Silicon: MCU with Integrated CAN, LIN Implementation, Ethernet Controller, Transitioning Between Protocols, Application Example.

#### **UNIT-V: STANDARDS FOR SMART SENSING (9 Periods)**

Introduction, Setting the Standards for Smart Sensors and Systems, IEEE 1451.1, IEEE 1451.2, IEEE 1451.3, IEEE 1451.4, IEEE 1451.5, IEEE 1451.6, IEEE 1451.7, Application Example.

**Total Periods: 45**

**Topics for Self Study are provided in the Lesson Plan**

#### **TEXT BOOKS:**

1. Nikolay Kirianaki, Sergey Yurish, Nestor Shpak, Vadim Deynaga , "*Data Acquisition and Signal Processing for Smart Sensors*", John Wiley & Sons Ltd, 1<sup>st</sup> edition, 2002.
2. Jacob Fraden , "*Handbook of Modern Sensors: Physics, Designs, And Applications*", Springer, 5<sup>th</sup> edition, 2016.
3. Randy Frank, "*Understanding Smart Sensors*", Artech House, 3<sup>rd</sup> Edition, 2013.

#### **REFERENCE BOOKS:**

1. Sergio Franco, "*Design with Operational Amplifiers and Analog Integrated Circuits*", McGraw-Hill Education, 4<sup>th</sup> edition, 2015.
2. G.K. Ananthasuresh K.J. Vinoy S. Gopala krishnan K.N. Bhat V.K. Aatre, "*Micro and Smart Systems: Technology and Modeling*", John Wiley & Sons, Inc., 1<sup>st</sup> edition, 2012.

#### **ADDITIONAL LEARNING RESOURCES:**

##### **1. Smart sensors:**

[https://www.electrochem.org/dl/interface/wtr/wtr10/wtr10\\_p029-034.pdf](https://www.electrochem.org/dl/interface/wtr/wtr10/wtr10_p029-034.pdf)

[https://www.ee.iitb.ac.in/~esgroup/es\\_mtech02\\_sem/es02\\_sem\\_rep\\_dubey.pdf](https://www.ee.iitb.ac.in/~esgroup/es_mtech02_sem/es02_sem_rep_dubey.pdf)

##### **2. MEMS Technologies: Photolithography**

[https://nanoscale.unl.edu/pdf/Photolithography\\_Participant\\_Guide.pdf](https://nanoscale.unl.edu/pdf/Photolithography_Participant_Guide.pdf)

##### **3. Standards for smart sensors- ieee-1451:**

<https://www.electronicdesign.com/technologies/components/article/21787128/smart-sensors-ieee-1451>.

### III B. Tech. – II Semester

#### (19BM61031) PROCESS CONTROL LAB

Int. Marks	Ext. Marks	Total Marks	L	T	P	C
50	50	100	-	-	2	1

**PRE-REQUISITES:** Course on Process Control Instrumentation.

**COURSE DESCRIPTION:** Tuning methods, Characteristics of control valve, Response of controllers for different processes like flow, level, pressure etc., Design of controllers.

**COURSE OUTCOMES:** After completion of the course the student will be able to

- CO1. Demonstrate knowledge on process equipments.
- CO2. Develop the transfer function of the process and analyze the performance of the process in terms of time domain specifications.
- CO3. Design electronic PID controller and tune its controller parameters using various tuning methods.
- CO4. Analyze the response of flow, level and pressure process.
- CO5. Work independently and in teams to solve problems with effective communication.

**LIST OF EXPERIMENTS:**

*(Minimum 10 experiments to be conducted)*

1. Analyze the behavior of Flow process with and without controller.
2. Obtain the performance for liquid level process with and without controller.
3. Response of Pressure Process using controller.
4. Obtain the transfer function model for Interacting Systems.
5. Obtain the transfer function model for Non-Interacting Systems.
6. Analyze the servo and regulatory response for pressure control process.
7. Obtain the characteristics of electro-pneumatic converter.
8. Obtain the controller parameters using Process reaction curve method.
9. Obtain the controller parameters using continuous oscillation method.
10. Study the response of ratio controller.
11. Study the closed loop performance of cascade controller.
12. Obtain the valve flow-lift characteristics of Linear, On-OFF and equal percentage control valve.



13. Realization of control actions- Electronic PID controller.

**REFERENCE BOOKS/LABORATORY MANUALS:**

1. Donald P. Eckman, *Automatic Process Control*, Wiley Eastern Ltd., 1993.
2. Curtis D. Johnson, *Process Control Instrumentation Technology*, Pearson Education, New Delhi, 7<sup>th</sup> Edition, 2002.

**ADDITIONAL LEARNING RESOURCES:**

1. [http://www.vlab.co.in/lab\\_ready\\_for\\_use.php](http://www.vlab.co.in/lab_ready_for_use.php)
2. <https://www.pidlab.com/en/>
3. <http://www.eiecouncil.com/process-control-lab.html>

## IV B. Tech. – I Semester

### (19BM71001) BIOMEDICAL INSTRUMENTATION

Int. Marks	Ext. Marks	Total Marks	L	T	P	C
40	60	100	3	-	-	3

#### PRE-REQUISITES: -

**COURSE DESCRIPTION:** Human Anatomy & Physiology; Bio-signals; Cardiovascular and Neuro-muscular Instrumentation; Therapeutic Equipment; Advanced Imaging techniques.

**COURSE OUTCOMES:** On successful completion of the course the students will be able to

- CO1 Demonstrate knowledge on Bioelectric Potentials and various electrodes for measuring Potentials.
- CO2 Analyze ECG signals and measure various cardiovascular parameters.
- CO3 Analyze EEG and EMG signals and measure various parameters in neuro muscular and respiratory systems.
- CO4 Demonstrate the working of various theraptic instruments.
- CO5 Demonstrate the working of imaging instruments used for diagnosis by following ethical values.

#### UNIT-I: BIO ELECTRIC POTENTIALS AND ELECTRODES (9 Periods)

Block diagram of biomedical instrumentation, Problems encountered in measuring a living system, system, Structure of cell, Resting and Action Potentials, Propagation of Action Potentials, sources of Bioelectric Potentials, Electrode theory, Bio potential electrodes, Bio chemical transducers.

#### UNIT-II: CARDIOVASCULAR INSTRUMENTATION (9 Periods)

Physiology of cardiovascular system, electrical conduction system of the heart, interpretation of ECG waveform, standard 12-lead configurations, Einthoven triangle, specifications of ECG Machine; Blood pressure, blood flow and heart sound measurements; Relation between electrical and mechanical activities of the heart.

#### UNIT-III:NEURO-MUSCULAR AND RESPIRATORY INSTRUMENTATION (9 Periods)

Physiology of nervous system, electrode placement for EEG and EMG recording, Specification of EEG and EMG machines, Interpretation of EEG and EMG.

Respiratory Instrumentation: Mechanism of respiration, Spirometry, Pnemuotachograph Ventilators.

**UNIT – IV: THERAPEUTIC EQUIPMENT****(9 Periods)**

Pacemakers: Need for Cardiac pacemakers, pacing modes, Ventricular asynchronous Pacemaker (Fixed rate Pacemaker), Ventricular inhibited Pacemaker (demand Pacemaker), Atrial Synchronous pacemaker, Comparison between internal & external Pacemakers; Defibrillators: AC Defibrillator, DC Defibrillator, Synchronised DC Defibrillator; Diathermy: Shortwave and microwave, Dialysis: Hemo Dialysis, Peritoneal Dialysis.

**UNIT – V: MEDICAL IMAGING SYSTEM****(9 Periods)**

Ultrasonic Imaging: Doppler principle, Modes of Display: A-Mode, B-Mode and Echocardiography. Computed Tomography: Block diagram of CT scanner, Applications of Computed Tomography. MRI Imaging System, Cine angiogram, Endoscope.

**Total Periods: 45****TEXTBOOKS:**

1. Leslie Cromwell, Fred. J. Weibell and Erich. A. Pfeiffer, "*Biomedical Instrumentation and Measurements*", 2nd Edition, PHI, 2003.
2. R.S. Khandpur, "*Hand Book of Biomedical Instrumentation*", Tata McGraw Hill, 2nd Edition, 2002.

**REFERENCE BOOKS:**

1. John G. Webster, "*Medical Instrumentation Application and Design*", 3<sup>rd</sup> Edition, Wiley India Pvt. Ltd., 2004
2. M. Arumugam, "*Biomedical Instrumentation*", Anuradha Publications, 1992.

**ADDITIONAL LEARNING RESOURCES:**

- <https://www.nibib.nih.gov/science-education/students-resource>
- [https://www.who.int/medical\\_devices/support](https://www.who.int/medical_devices/support)
- <https://nptel.ac.in>

**IV B. Tech. – I Semester**  
**(19BM71002) PROGRAMMABLE LOGIC CONTROLLERS**

Int. Marks	Ext. Marks	Total Marks	L	T	P	C
40	60	100	3	-	-	3

**PRE-REQUISITES: -**

**COURSE DESCRIPTION:** Introduction to PLC, PLC ladder diagrams, programming PLC, timers, counters and sequences used in PLC, data handling functions, bit Patterns, advanced PLC functions.

**COURSE OUTCOMES:** After successful completion of the course, students will be able to:

- CO1. Demonstrate knowledge on programmable logic controllers, various functions of PLCs.
- CO2. Analyse the process of automation using PLC functions.
- CO3. Develop programs for industrial applications to automate the process using PLC functions.
- CO4. Solve real time problems in industries using PLCs.

**DETAILED SYLLABUS:**

**UNIT-I: PLC BASICS AND PROGRAMMING (9 Periods)**

Introduction, PLC advantages, disadvantages, PLC system, CPU,I/O modules and interfacing, power supplies, Programming equipment, Programming formats, Construction of PLC ladder diagrams, Devices connected to I/O modules. Input instructions, outputs, Operational procedures, Programming examples using contacts and coils, Fail-Safe Circuits, Drill press operation.

**UNIT-II: LADDER DIAGRAMS, REGISTERS AND TIMER FUNCTIONS**

**(9 Periods)**

Digital logic gates, Boolean algebra PLC programming, Conversion examples. Ladder Diagrams for process control: Ladder diagrams & sequence listings, ladder diagram construction and flowchart for spray process system. Characteristics of Registers, module addressing, holding registers, Input Registers, Output Registers. Timer function & Industrial applications, Counter functions & industrial applications.

**UNIT-III: INTERMEDIATE AND DATA HANDLING FUNCTIONS (9 Periods)**

Intermediate functions: Arithmetic functions, Number comparison functions, Number conversion functions. Skip, Master control relay, Jump functions. PLC data move systems: Move function, FIFO, FAL, & Sweep functions and their applications.

**UNIT-IV: PLC FUNCTIONS WORKING WITH BITS****(8 Periods)**

Bit Pattern, Changing a register bit status, Shift register functions and applications, Sequencer functions and applications, Controlling of two-axis & three axis Robots with PLC, Matrix functions.

**UNIT-V: ADVANCED PLC FUNCTIONS****(10 Periods)**

Analog modules & systems, Analog signal processing, Multi-bit Data Processing, Analog output application examples, PID principle, position indicator with PID control, PID Modules, PID tuning, PID functions, Networking of PLCs, Alternative Programming languages.

**Total Periods: 45**

*Topics for self-study are provided in the lesson plan*

**TEXT BOOK:**

1. John W. Webb & Ronald A. Reiss, *Programmable Logic Controllers Principles and Applications*, 5<sup>th</sup> edition, PHI 2009.

**REFERENCE BOOKS:**

1. Frank D. Petruzella, *Programmable Logic Controller*, 3<sup>rd</sup> edition, Tata Mc-Graw Hill, 2010.
2. M. Chidambaram, *Computer Control of Process*, Narosa 2003.

**ADDITIONAL LEARNING RESOURCES**

1. <https://openautomationsoftware.com/use-cases/allenbradleywpcfscada/>
2. <https://new.siemens.com/global/en/products/automation/industrysoftware/automationsoftware/scada.html>
3. <https://ab.rockwellautomation.com/Programmable-Controllers>

## IV B. Tech. – I Semester

### (19BM71031) BIOMEDICAL INSTRUMENTATION LAB

Int. Marks	Ext. Marks	Total Marks	L	T	P	C
50	50	100	-	-	2	1

**PRE-REQUISITES:** Course on Biomedical Instrumentation.

**COURSE DESCRIPTION:** Measurements of parameters: pH, Dissolved Oxygen, Conductivity blood pressure, respiration rate and heart sounds; Analysis of Bio-Signals; Compression of Bio-Signals.

**COURSE OUTCOMES:** After successful completion of the course, students will be able to:

- CO1 Select suitable biomedical instrument for specific measurement of physiological parameters.
- CO2 parameters.
- CO3 Design signal conditioning circuit for various biosensors.
- CO4 Analyze the response of various biosignals to detect abnormalities.
- CO5 Work independently and in teams to solve problems with effective communication.

#### LIST OF EXPERIMENTS:

##### Minimum of TEN experiments to be conducted

1. Calibration and measurement of pH value, Dissolved Oxygen and Thermal Conductivity of a given sample.
2. Blood pressure measurement.
3. Analysis of ECG for different lead configurations.
4. Analysis of EEG Signals.
5. Analysis of EMG Signals.
6. Design of Instrumentation Amplifier for bioelectrical Signals.
7. Measurement of Heart Sounds.
8. Real time EPR System.
9. Electrical Safety analyzer for biomedical equipments.
10. Analysis of Bio-Signals using Lab View.
11. Compression of Bio-Signals using Lab View.
12. Flame photometer for biomedical applications.
13. Study and analyze the performance of UV-VIS Spectrophotometer.

**REFERENCE BOOKS/LABORATORY MANUALS:**

1. Leslie Cromwell, Fred. J. Weibell and Erich. A. Pfeiffer, "*Biomedical Instrumentation and Measurements*", 2nd Edition, PHI, 2003.
2. R.S. Khandpur, "*Hand Book of Biomedical Instrumentation*", Tata McGraw Hill, 2nd Edition, 2002.
3. John G. Webster, "*Medical Instrumentation Application and Design*", 3<sup>rd</sup> Edition, Wiley India Pvt. Ltd., 2004

**ADDITIONAL LEARNING RESOURCES:**

1. Lab view 2013 biomedical toolkit.
2. <http://www.vlab.co.in/ba-nptel-labs-biotechnology-and-biomedical-engineering>
3. <https://physionet.org/>

## **MINOR DEGREE IN ROBOTICS**

**Offering Department:** MECHANICAL ENGINEERING

**Students of Eligible Branches:** CSE, CSSE, IT, ECE, EEE, EIE and CE

### **COURSE STRUCTURE**

Semester	Course Code	Course Title	Contact Periods per week				Credits	Scheme of Examination Max. Marks		
			L	T	P	Total		Int. Marks	Ext. Marks	Total Marks
III B.Tech. I-Sem (2 Theory)	19BM50301	Computer Integrated Manufacturing	3	-	-	3	3	40	60	100
	19BM50302	CNC Programming	3	-	-	3	3	40	60	100
	19BM50303	Introduction to Mechanical systems *	3	-	-	3	3	40	60	100
III B.Tech. II-Sem (2 Theory)	19BM60301	Principles of Industrial Automation	3	-	-	3	3	40	60	100
	19BM60302	Principles of Robotics*	3	-	-	3	3	40	60	100
	19BM60303	Robot Kinematics and Dynamics	3	-	-	3	3	40	60	100
IV B.Tech. I-Sem (2 Theory)	19BM70301	Applied and Industrial Robotics	3	-	-	3	3	40	60	100
	19BM70302	Robotic Programming	3	-	-	3	3	40	60	100
	19BM70303	Sensors and Machine Vision Systems	3	-	-	3	3	40	60	100

\*Compulsory Course if not studied in major degree

**Note:** If any student has chosen a course from the above list in their regular curriculum then, he/she is not eligible to opt the same course/s for the Minor degree. It is the responsibility of the student to acquire/complete prerequisite before taking the respective course.



### III B. Tech. – I Semester

#### (19BM50301) COMPUTER INTEGRATED MANUFACTURING

Int. Marks	Ext.Marks	TotalMarks	L	T	P	C
40	60	100	3	-	-	3

**PRE-REQUISITES:** -

**COURSE DESCRIPTION:** Introduction to CIM, CAD/CAM, product life cycle, Fundamentals of NC and CNC, Group Technology AND FMS, Computer Aided Planning Systems, Adaptive control systems

**COURSE OUTCOMES:** On successful completion of this course, students will be able to:

- CO1. Apply the principles of Computer integrated manufacturing to control and foster the production process.
- CO2. Analyze the architecture of numerical control and apply the Numerical control programming techniques for machining process.
- CO3. Analyze different part families through grouping and construe different machine cell designs and flexible manufacturing systems.
- CO4. Demonstrate different approaches and techniques for computer aided process planning in automation.
- CO5. Demonstrate the knowledge on Adaptive control systems for different applications.

**DETAILED SYLLABUS:**

**UNIT - I: FUNDAMENTALS OF CIM (9 Periods)**

Introduction to Manufacturing; CIM -Types, Manufacturing Systems, CIM Definition, CIM wheel, CIM components, Evolution of CIM - Development of computers, needs of CIM, Benefits of CIM, CIM Hardware & Software, Fundamentals of CAD / CAM, Product cycle.

**UNIT-II: FUNDAMENTALS OF NC AND CNC (9Periods)**

**Numerical control machines:** Introduction, basic components of an NC system, the NC procedure, NC coordinate system, NC motion control system, application of numerical control and Economics of Numerical control.

**Computer controls in NC:** Principle of CNC, types of CNC machine tools, programming and applications of CNC machine tools, Direct Numerical control (DNC), Database and DBMS- requirement, features and architecture of DBMS.

**UNIT - III: GROUP TECHNOLOGY AND FMS (9 Periods)**

**Group Technology:** Group Technology - Part families, Parts classification and coding,

Production flow analysis, Composite part concept, Machine cell design and Benefits of GT.

**Flexible Manufacturing Systems:** FMS - Components of FMS, FMS Work stations, Material Handling Systems, Computer Control system, FMS layout configurations and Benefits of FMS.

**UNIT-IV: COMPUTER AIDED PLANNING SYSTEMS (9 Periods)**

Computer aided planning systems - Approaches to Computer aided Process Planning (CAPP), Generative and Retrieval CAPP systems, Benefits of CAPP, Material Requirement Planning (MRP), Mechanism of MRP, Benefits of Capacity Planning.

**UNIT - V: ADAPTIVE CONTROL SYSTEMS: (9 Periods)**

Adaptive control machining system - Adaptive control optimization system, Adaptive control constraint system, Applications to machining processes, Computer process monitoring, Hierarchical structure of computers in manufacturing, and computer process control.

**Total Periods: 45**

***Topics for self-study are provided in the lesson plan***

**TEXT BOOKS:**

1. Mikel.P.Groover, *Automation, Production systems and Computer Integrated Manufacturing Systems*, Pearson Education; 4th Edition,2016.
2. P.N.Rao, *CAD/CAM: Principles and Applications*, McGraw Hill Education, 3rd edition, 2017.

**REFERENCE BOOKS:**

1. Radhakrishnan and Subramanian, *CAD/CAM/CIM*, New Age International Pvt Ltd, 4<sup>th</sup> Edition, 2018.
2. M. Groover, *CAD/CAM*, Pearson Education; 1<sup>st</sup> Edition, 2003.

**III B. Tech. – I Semester**  
**(19BM50302) CNC PROGRAMMING**

Int. Marks	Ext. Marks	Total Marks	L	T	P	C
40	60	100	3	-	-	3

**PRE-REQUISITES: -**

**COURSE DESCRIPTION:**

Fundamentals of NC And CNC Machines, CNC Machine Elements, CNC Machine Structure and Machining Centers, Machining Centers, Adaptive Control Systems and Drives, DNC Systems and Adaptive Control, Feedback Devices, Fundamentals of CNC Programming, CNC Part Programming, CNC Turning and Milling Programming, CNC Turning, CNC Milling.

**COURSE OUTCOMES:** After successful completion of this course, the students will be able to:

- CO1.** Demonstrate the knowledge of numerical controls & computerized numerical control of a manufacturing system.
- CO2.** Demonstrate the knowledge of constructional and functional features of machines and its support systems.
- CO3.** Analyze CNC machines with the knowledge of Adaptive control systems and drive systems considering societal needs.
- CO4.** Apply CNC coding used in CNC programming for a given operation.
- CO5.** Apply CNC programming for basic Turning and Milling Operations.

**DETAILED SYLLABUS:**

**UNIT- I: FUNDAMENTALS OF NC and CNC MACHINES (9 Periods)**

**NC machines:** Fundamentals of numerical control, advantage of NC systems, classification of NC systems, point to point, NC and CNC, incremental and absolute, open and closed loop systems, features of NC Machine tools, interpolations.

**CNC Machines:** CNC machine elements, principle of operation of CNC, features of CNC, classification of CNC systems, Advantages of CNC system, Application of CNC systems.

**UNIT- II: CNC MACHINE STRUCTURE AND MACHINING CENTERS (9 Periods)**

**CNC Machine Structure:** Guide ways, feed drives, spindles, spindle bearings, slide ways - Friction, Antifriction and types of guide ways; Recirculating ball screw; Torque transmission elements - gears, timing belts, flexible couplings and bearings.

**Machining centers:** Features, Auto Tool Changer (ATC) & Automatic Pallet Changer (APC).

**UNIT- III: ADAPTIVE CONTROL SYSTEMS AND DRIVES (9 Periods)**

**DNC Systems and Adaptive Control:** Introduction, type of DNC systems, advantages and disadvantages of DNC, adaptive control with optimization, adaptive control with constraints. **Feedback devices** – Open loop and closed loop control systems, positional feedback, velocity feedback devices.

**Drives:** spindle drives-DC shunt motor, 3 phase induction motor, Feed drives-stepper motors, servo principle, DC and AC servomotors.

**UNIT- IV: CNC PROGRAMMING****(9 Periods)**

**CNC PART PROGRAMMING:** Coordinate systems- structure of part program, Types of interpolation, Methods of CNC part programming, Part Program Terminology-G and M Codes, Machine and work piece datum, absolute and incremental programming, tool offset and tool nose radius compensation, fixed cycles, subroutines in part programming, computer-aided part programming, CNC controllers (FANUC and SINUMERIC),

**UNIT- V: CNC TURNING AND MILLING PROGRAMMING****(9 Periods)**

**CNC Turning:** Basic programs on Turning, Facing, Drilling, Threading, Taper Turning, Boring, reaming, and tapping

**CNC Milling:** Basic programs on Face Milling, End Milling, Drilling, Chamfering, Boring, Reaming, Tapping, Sinking.

Features of typical CAM packages: Master CAM, Edge CAM, Siemens NX CAM.

**Total Periods: 45**

**Topics for self-study are provided in the lesson plan**

**TEXT BOOKS:**

1. Mike Mattson, *CNC Programming: Principles & Applications: Principles and Applications*, Delmar; 1st edition, 2013.
2. Yorem Koren, *Computer Control of Manufacturing Systems*, Mc Graw Hill Book Co, 2017.
3. P. Radhakrishnan, *Computer Numerical Control (CNC) Machines*, New Central Book Agency; 1st edition, 2013

**REFERENCE BOOKS:**

1. M. Adithan and B.S. Pable, *CNC Machines*, New Age, Third edition, 2018.
2. Mikell P. Groover, *Automation, Production Systems and Computer-Integrated Manufacturing*, Pearson Education; Fourth edition, 2016.
3. J.S. Narang, *CNC Machines And Automation*, Dhanpat Rai & Co. (P) Limited, 2016.

### III B.Tech. – I Semester

#### (19BM50303) INTRODUCTION TO MECHANICAL SYSTEMS

Int. Marks	Ext. Marks	Total Marks	L	T	P	C
40	60	100	3	-	-	3

#### PRE-REQUISITES: -

#### COURSE DESCRIPTION:

Statics of rigid bodies; Laws of mechanics; Force couple system; Equilibrium of rigid bodies; Supports and reactions forces; Moment and couple and their representation; Dynamics of rigid bodies; Motion of a rigid bodies; Energy equations; Frictional forces; Robotics and automation; Configuration and anatomy of robots; End effectors; Robotic drive and control systems; Actuators.

**COURSE OUTCOMES:** After successful completion of this course, the students will be able to:

- CO1. Analyze the mechanical behavior of a rigid body and components of forces involved in it.
- CO2. Analyze conditions of equilibrium applied over a rigid body in different dimensions and compute its moments and couples.
- CO3. Analyze the dynamic behavior of a rigid body and its condition of motion.
- CO4. Demonstrate knowledge of robots and its components.
- CO5. Analyze the functional characteristics of robot drives, actuators and controls for a configurations.

#### DETAILED SYLLABUS:

#### UNIT- I: STATICS (9 Periods)

Introduction, Units and Dimensions, Laws of Mechanics, Force Characteristics, System of forces, Lami's theorem, Parallelogram and triangular Law of forces, Statics of rigid bodies in two dimensions, force couple system.

#### UNIT- II: EQUILIBRIUM OF RIGID BODIES (9 Periods)

Free body diagram, Types of supports, Action and reaction forces, Moments and Couples, Moment of a force about a point and about an axis, Vectorial representation of moments and couples, Varignon's theorem, Equilibrium of Rigid bodies in two dimensions.

#### UNIT- III: RIGID BODY DYNAMICS (9 Periods)

Displacements, Velocity and acceleration, their relationship, Relative motion, Curvilinear motion, Newton's laws of motion, Work Energy Equation; Friction force – Laws of sliding friction, Equilibrium analysis of simple systems with sliding friction.

#### UNIT- IV: ROBOTICS (9 Periods)

Robotics and programmable automation, Law of robotics, Anatomy, Configuration of robots, Robot end effectors-classification, force analysis, active and passive grippers.

**UNIT-V: ROBOTIC DRIVES, ACTUATORS & CONTROLS (9 Periods)**

Functions of Drive Systems, General Types of Fluids, Classification of fluid power systems, Components of hydraulic fluid power systems, components of pneumatic systems, Pump Classification, Introduction to Pneumatic Systems, Electrical Drives, D.C. Motors and Transfer Functions, A.C. Motors, Piezoelectric Actuators, Stepper Motor, Drive Mechanisms.

**Total Periods: 45**

**Topics for self-study are provided in the lesson plan**

**TEXT BOOKS:**

1. Beer F.P, Johnston Jr.E.R, *Vector Mechanics for Engineers Statics and Dynamics*, McGraw Hill Education, 11th Edition, 2017.
2. Mikell P Groover, Mitchell Weiss, Roger N Nagel, Nicholas Odrey, Ashish Dutta *"Industrial Robotics (SIE): Technology, Programming and Applications*, McGraw Hill Education India, 2012
3. S.R. Deb and S.Deb *"Robotic Technology and Flexible Automation"* McGraw Hill Education India. Second Edition, 2012.
4. Khushdeep goyal, Deepak Bhandari, *Industrial automation and robotics*, Katson books, 2013.

**REFERENCE BOOKS:**

1. Hibbeler R.C, Ashok Gupta *"Engineering Mechanics Statics and Dynamics"*, Pearson Education, 11th Edition, 2009.
2. Bhavikatti S.S *"Engineering Mechanics"*, 7th Edition, New Age International (P) Limited Publishers, 2019.
3. Young D H, Timashenko S *"Engineering Mechanics"*, Tata McGraw-Hill., 2006
4. S K Saha *"Introduction to Robotics"*, 2nd Edition, McGraw Hill Education India, 2014.

### III B. Tech. – II Semester

#### (19BM60301) PRINCIPLES OF INDUSTRIAL AUTOMATION

Int. Marks	Ext. Marks	Total Marks	L	T	P	C
40	60	100	3	-	-	3

**PRE-REQUISITES: -**

**COURSE DESCRIPTION:** Introduction to automation, Types of automation systems, Fluid power and fluid power systems, Assembly automation equipment, Material handling, transfer and assembly equipment, Types of automated assembly machines, Programmable Logic Controllers, PLC hardware components, Microprocessors and Microcontrollers, Feedback devices.

**COURSE OUTCOMES:** On successful completion of this course, students will be able to:

- CO1: Demonstrate the knowledge on automation and its different applications.
- CO2: Analyze functional characteristics of power systems for industrial applications.
- CO3: Demonstrate the knowledge on assembly automation equipment and its related components.
- CO4: Demonstrate the knowledge of programming logic controller unit for industrial applications.
- CO5: Demonstrate the knowledge of microprocessors and microcontrollers in integrating mechanical systems with computer and electronic systems.

**DETAILED SYLLABUS:**

**UNIT-I: INTRODUCTION TO AUTOMATION (9 Periods)**

History, Elements of Automation, Types of Automation systems, Applications of Automation, Goals of Automation, Low cost automation, Hierarchical levels in industrial Automation systems.

**UNIT-II: FLUID POWER AND FLUID POWER SYSTEMS (9 Periods)**

Introduction to fluid power- Classification of fluid power systems, comparison of electrical, hydraulic and Pneumatic systems; Basic circuit diagram of Hydraulic fluid power and pneumatic power systems, Components of Hydraulic fluid power systems, Components of Pneumatic power system, Logic Gates, Truth tables and Boolean algebra.

**UNIT-III: ASSEMBLY AUTOMATION EQUIPMENT (9 Periods)**

**Material Handling :** Principles of Material handling, Material handling equipment- Wheel conveyor, Gravity Roller conveyor, Chain conveyor, Flat belt conveyor, Magnetic belt conveyor, bucket conveyor, Vibrating conveyor, screw conveyor, vertical lift conveyor, trolley conveyor, sortation conveyor, cranes and Hoists, storage equipment, AS/RS,

AGV.

**Transfer and assembly equipment:** Introduction to feeder units, Cycled transfer equipment and non-cycled transfer equipment.

**Automated assembly machines:** Dial indexing machine, In-line machine, and floating work platform machines.

#### **UNIT-IV: PROGRAMMABLE LOGIC CONTROLLERS (9 Periods)**

**Programmable Logic Controllers (PLC):** Parts of a PLC, Principles of Operation, Modifying the Operation, PLCs versus Computers, PLC Size and Applications.

**PLC hardware Components:** The I/O Section, Discrete I/O Modules, Analog I/O Modules, Special I/O Modules, I/O Specifications, Typical Discrete I/O Module Specifications, Typical Analog I/O Module Specifications, The Central Processing Unit (CPU), Memory Types, Programming Terminal Devices, Recording and Retrieving Data, Human Machine Interfaces (HMIs).

#### **UNIT-V: MICROPROCESSORS AND MICROCONTROLLERS (9 Periods)**

Evolution of microprocessors and microcontrollers; Architectures of microprocessors and microcontrollers; Integration of mechanical systems with computer and electronic systems (Mechatronic systems).

**Feedback devices:** LVDT, Linear/Rotary encoders, absolute encoders, resolvers and potentiometers, Fundamentals of SCADA and Data Acquisition Systems.

**Total Periods: 45**

***Topics for self-study are provided in the lesson plan***

#### **TEXT BOOKS:**

1. Khushdeep Goyal, *Industrial Automation and Robotics*, S.K.Kataria & Sons, 4<sup>th</sup> Edition, 2013.
2. Frank. D. Petruzella, *Programmable Logic Controllers*, Tata McGraw-Hill Education, 4<sup>th</sup> Edition, 2011.

#### **REFERENCE BOOKS:**

1. M.P. Groover, *Automation, Production systems and Computer Integrated Manufacturing*, Fourth edition, PHI Learning, 2016.
2. Geoffrey Boothroyd, *Assembly Automation and Product design*, Taylor and Francis Publishers, Second edition 2005.



### III B.Tech. II-Semester

#### (19BM60302) PRINCIPLES OF ROBOTICS

Int. Marks	Ext. Marks	Total Marks	L	T	P	C
40	60	100	3	-	-	3

#### PRE-REQUISITES: -

**COURSE DESCRIPTION:** Brief history - Robot – Definition, Various robot manipulators – Linear and angular velocities, tactile, proximity and range sensors, End Effectors and robot economics

**COURSE OUTCOMES:** On successful completion of this course, the students will be able to:

- CO1. Demonstrate knowledge of robotics, its specifications, functions and different applications.
- CO2. Demonstrate knowledge on various robot manipulators
- CO3. Demonstrate knowledge on sensors, work cells and programming languages.
- CO4. Analyze functional characteristics of robot end effectors through design considerations.
- CO5. Analyze economic aspects of robots by considering different safety parameters.

#### DETAILED SYLLABUS:

##### UNIT-I: BASIC CONCEPTS

(9 Periods)

Brief history, Robot - Definition, Anatomy; Co-ordinate Systems, Work Envelope types and Classification, Robotic Specifications, Pitch, Yaw, Roll, Joint Notations, Speed of Motion, Pay Load, Robot Parts and their Function; Need for Robots, Applications.

##### UNIT-II: ROBOT MANIPULATORS

(9 Periods)

Various robot manipulators, Linear and angular velocities, Manipulator Jacobian, Prismatic and rotary joints, Robotic Inverse, Wrist and arm singularity.

##### UNIT-III: ROBOT SENSORS

(9 periods)

Desirable features of Sensors; Tactile, proximity and range sensors; Uses of sensors in robotics; work cell; Introduction to Programming languages.

##### UNIT-IV: ROBOT END EFFECTORS

(9 periods)

End Effectors-Grippers-Mechanical Grippers, Pneumatic and Hydraulic Grippers, Magnetic Grippers, Vacuum Grippers; Two Fingered and Three Fingered Grippers; Internal Grippers and External Grippers; Selection and Design Considerations.

##### UNIT-V:IMPLEMENTATION AND ROBOT ECONOMICS

(9 periods)

RGV, AGV; Implementation of Robots in Industries-Variou Steps; Safety Considerations for Robot Operations - Economic Analysis of Robots.

**Total Periods: 45**

**Topics for self-study are provided in the lesson plan**

#### TEXT BOOKS:

1. R.K.Mittal and I.J.Nagrath, *Robotics and Control*, Tata McGraw Hill, New Delhi,4th Reprint, 2005.

2. M.P.Groover, M.Weiss, R.N. Nageland N. G.Odrej, *Industrial Robotics*, McGraw-Hill Singapore, 1996.

**REFERENCE BOOKS:**

1. JohnJ.Craig ,*Introduction to Robotics Mechanics and Control*, Pearson Education, Third edition, 2009.
2. Ashitava Ghoshal, *Robotics-Fundamental Concepts and Analysis*, Oxford University Press, Sixth impression, 2010.

### III B. Tech. – II Semester

#### (19BM60303) ROBOT KINEMATICS AND DYNAMICS

Int. Marks	Ext. Marks	Total Marks	L	T	P	C
40	60	100	3	-	-	3

#### PRE-REQUISITES: -

**COURSE DESCRIPTION:** Robot Manipulation, Robot Classification, Robot Specifications, Direct Kinematics, Inverse Kinematics, Manipulator Differential Motion and Statics, Manipulator Jacobian, Dynamic Modeling,

**COURSE OUTCOMES:** On successful completion of this course, students will be able to:

- CO1. Demonstrate the knowledge on robot manipulation and control for industrial applications
- CO2. Analyze forward and Inverse kinematics for different robot schemes.
- CO3. Analyze manipulator differential motion and statics for different robot schemes
- CO4. Develop dynamic models for robots using Langrangian mechanics, Lagrange–Euler formulation, Newton–Euler formulation and other techniques.

#### DETAILED SYLLABUS:

##### UNIT-I: ROBOT MANIPULATION (9 Periods)

Automation and robots; Robot anatomy; Robot Classification; Manipulation and control; Applications; Robot Specifications–Number of axes, Capacity and speed, Reach and stroke, Tool orientation, Repeatability, precision and accuracy, Operating environment.

##### UNIT-II: DIRECT KINEMATICS (9 Periods)

Dot and cross products; coordinate frames; Rotations; Homogeneous coordinates; link coordinates; D-H Representation; The ARM equation; Schematic diagram of four, five and six axis articulated robot.

##### UNIT-III: INVERSE KINEMATICS (9 Periods)

Manipulator workspace; Solvability of inverse kinematic model; Existence of solutions; Multiple solutions, Solution techniques; Closed form solution; The inverse kinematics problem; General properties of solutions; Tool configuration; Inverse kinematics of four axis SCARA robot and six axis articulated robot.

##### UNIT-IV: MANIPULATOR DIFFERENTIAL MOTION AND STATICS (9 Periods)

Linear and angular velocity of a rigid body; Relationships between transformation; Mapping, Velocity vector; Velocity propagation along links; Manipulator Jacobian;

Jacobian inverse; Jacobian singularities; Static analysis.

**UNIT V: DYNAMIC MODELING:**

**(9 Periods)**

Langrangian mechanics; Two degree of freedom manipulator–Dynamic model, Lagrange –Euler formulation, Newton–Euler formulation; Comparison of Lagrange–Euler formulation and Newton–Euler formulation; Inverse dynamics.

**Total Periods: 45**

***Topics for self-study are provided in the lesson plan***

**TEXT BOOKS:**

1. Robert J. Schilling, *Fundamentals of Robotics Analysis and Control*, PHI Learning 2011.
2. R.K.Mittal and Nagrath, *Robotics and Control*, TMH, 2017.

**REFERENCE BOOKS:**

1. Niku S B, *Introduction to Robotics, Analysis, Systems, Applications*, Prentice Hall, Second edition 2006.
2. Geoffrey Boothroyd, *Assembly Automation and Product design*, Taylor and Francis Publishers, Second edition 2005.

## IV B.Tech I Semester

### (19BM70301) APPLIED AND INDUSTRIAL ROBOTICS

Int. Marks	Ext. Marks	Total Marks	L	T	P	C
40	60	100	3	-	-	3

#### PRE-REQUISITES: -

**COURSE DESCRIPTION:** General considerations in Robot material handling, material transfer application, machine loading and unloading, CNC machine tool loading; repeatability, maximum working envelop, kinematic and state values. Robot safety Considerations, Factors affecting robot safety measures; Cooperative manipulation; field robots and robots in health care

**COURSE OUTCOMES:** On successful completion of this course, the student will be able to:

- CO1. Demonstrate the knowledge on robotic material handling and assembly systems.
- CO2. Demonstrate the knowledge of expert systems in robotic performance testing and safety
- CO3. Demonstrate the knowledge on various cooperative and SWARM robots and its applications.
- CO4. Analyze robotic configurations and specifications for field and service applications.
- CO5. Demonstrate the core concepts of robots in medical applications.

#### DETAILED SYLLABUS:

##### UNIT- I: ROBOT MATERIAL HANDLING (10 periods)

General considerations in Robot material handling, material transfer application, machine loading and unloading, CNC machine tool loading, Robot centered cell Assembly and parts presentation methods, Assembly operation, Compliance and the Remote center compliance (RCC) Device, Assembly system configurations, Adaptable programmable assembly system, Designing for robotic assembly, Inspection automations - vision inspection system, robot - manipulated inspection.

##### UNIT- II: EXPERT SYSTEMS (9 periods)

Factors influencing the choice of a robot, Robot performance testing - Path/point accuracy and repeatability, Maximum working envelop, Kinematic and State values. Robot safety Considerations, Factors affecting robot safety measures, Safety features built into industrial robot, Safety barriers and other devices.

##### UNIT-III: COOPERATIVE AND SWARM ROBOTS (7 periods)

Cooperative manipulation, Challenges in cooperative manipulation- Case studies for Cooperative manipulation for Industrial and Service applications; Introduction to swarm Robots, Comparison with other multi-agent systems, challenges and benefits of swarm systems- Algorithms for swarm Robots, application, case study of swarm Robots.

**UNIT-IV: FIELD ROBOTS****(10 periods)**

Forestry, Robot locomotion, Forestry automation, Broad acre Applications- Automatic guidance, sowing, weeding, spraying and broad-acre harvesting; Horticulture, Picking of fruits, Robot milking, Sheep shearing, Slaughtering, livestock inspection, Robots in construction, Future directions; Robots for hazardous applications, Enabling technologies- Search and Rescue robotics: Disaster characteristics-Impact on Robots, Robots actually used at disaster, Promising robots, open issues – Case studies; Cleaning Robots, lawn moving Robots- Smart appliances and smart homes.

**UNIT-V: ROBOTS IN HEALTH CARE****(9 periods)**

Medical robotics, Core concepts, Technology- Medical robotic systems, Research areas and applications; Rehabilitation and Health care robotics- Overview, physical therapy and training Robots; Robotic aid for people with disabilities- Smart prostheses and orthoses, diagnosis and monitoring.

**Total Periods: 45**

**Topics for self-study are provided in the lesson plan**

**TEXT BOOKS:**

1. Mikell P. Groover, Mitchell Weiss, Roger N. Nagel and Nicholas G. Odrey, *Industrial Robotics Technology, Programming and Applications*, Mc Graw Hill Book company, 4<sup>th</sup> edition, 2016.
2. Bernard Hodges, *Industrial Robotics*, Second Edition, Jaico Publishing House, 1993.

**REFERENCE BOOKS:**

1. Yangsheng Xu Huihuan Qian Xinyu Wu, *Household and Service Robots*, ElsevierLtd,2015.
2. Aleksandar Lazinica, *-MobileRobotsTowards NewApplications*, Advanced Robotic SystemsInternational, 2006.
3. LMarques, Ade Almeida, Mo Tokhi,GSVirk, *-Advancesin MobileRobotics*, World Scientific PublishingCo. Pte.Ltd. 2008.
4. Bruno Siciliano, OussamaKhatib, *-Springer Handbook of Robotics*, Springer-Verlag BerlinHeidelberg, 2008.

## IV B.Tech. – I Semester

### (19BM70302) ROBOTIC PROGRAMMING

Int. Marks	Ext. Marks	Total Marks	L	T	P	C
40	60	100	3	-	-	3

#### PRE-REQUISITES: -

**COURSE DESCRIPTION:** Robotic programming; Robotic software functions; Program planning; Modes of programming; Commands for motion control; Lead through robotic programming; Textual robotic programming; End effectors and sensors commands; Program control and subroutines; VAL II Programming; AML Programming;

**COURSE OUTCOMES:** After successful completion of this course, the students will be able to:

- CO1. Demonstrate the knowledge of basic planning schemes involved in development of robotic programming.
- CO2. Develop Programmes for robots based on the techniques of pendant and command control.
- CO3. Demonstrate the knowledge of robotic languages for operations and control.
- CO4. Develop Programs for robots on VAL II platform with a complete command-based control.
- CO5: Develop Programs for robots on AML platform with a complete command-based control.

#### DETAILED SYLLABUS:

##### UNIT- I: FUNDAMENTALS OF ROBOT PROGRAMMING (9 Periods)

Robot software functions - coordinate systems, Position control, Other control functions, sub-routines, Planning of robotic programming using flow charting - examples.

##### UNIT-II: METHODS OF ROBOT PROGRAMMING (9 Periods)

Online programming, off-line programming advantages of off-line programming; lead through methods - powered lead through, manual lead through, Teach pendant; Robot program as a path in space, defining position in space, motion interpolation, WAIT, SIGNAL and DELAY commands, Branching capabilities and Limitations of lead through methods.

##### UNIT-III: ROBOT LANGUAGES (9 Periods)

Textual robot Languages, first generation and Second-generation languages, Structure of a robot language - Operating Systems, Elements and Functions, Constants, Variables and Other data objects, Motion commands, Points in workspace, End effectors and sensor commands, Computations and operations, Program control and subroutines, Communications and Data processing.

##### UNIT-IV: VARIABLE ASSEMBLY LANGUAGE (9 Periods)

Variable Assembly Language II - Introduction, Monitor commands, motion command, Hand Control, Configuration control, interlock commands, INPUT/OUTPUT Controls, Program Control, Examples

**UNIT- V: A MANUFACTURING LANGUAGE****(9 Periods)**

A Manufacturing Language(AML) - Introduction, AML statements, Constant and variables, Program control statements, motion commands, Sensor commands; Grip sensing capabilities, Data processing, Examples.

**Total Periods: 45**

***Topics for self-study are provided in the lesson plan***

**TEXT BOOKS:**

1. Mikell P. Groover, Mitchell Weiss, Roger N. Nagel and Nicholas G. Odrey, *Industrial Robotics Technology, Programming and Applications*, McGraw Hill Book company, 1986
2. Bernard Hodges, *Industrial Robotic*, Jaico Publishing House, 2<sup>nd</sup> Edition, 1993.
3. S.R. Deb and S.Deb *Robotic Technology and Flexible Automation*, Second Edition McGraw Hill Education India., 2012

**REFERENCES:**

1. JJ Craig, *Introduction to Robotic Mechanics and Control*, Pearson, 3<sup>rd</sup> edition, 2004.
2. Fu, Lee and Gonzalez, *Robotics, control vision and intelligence*, McGraw Hill International, 2nd edition, 1987.



## IV B.Tech. – I Semester

### (19BM70303) SENSORS AND MACHINE VISION SYSTEMS

Int. Marks	Ext. Marks	Total Marks	L	T	P	C
40	60	100	3	-	-	3

#### PRE-REQUISITES: -

**COURSE DESCRIPTION:** Vision systems; Components of vision systems; Elements of visual perception; Low level vision; Filters; Higher level visions; Boundary and regional description; Sensors in robots; Different sensing variables; Robotic control; Robotic operating System; Open CV.

**COURSE OUTCOMES:** After successful completion of this course, the students will be able to:

CO1. Demonstrate the knowledge of vision system components and image interfaces.

CO2. Demonstrate the knowledge of image representations and filters for low level vision system.

CO3. Demonstrate the knowledge of higher level vision for industrial applications.

CO4. Analyze functional characteristics of sensors incorporated in a robot system.

CO5. Demonstrate the knowledge on robotic operating system and vision system for robotic simulation.

#### DETAILED SYLLABUS:

##### UNIT-I: VISION SYSTEM

(9 Periods)

Basic Components, Elements of visual perception: structure of human eye, Image formation in the eye – pinhole cameras - color cameras – Image formation model – Imaging components and illumination techniques-Picture coding–Basic relationship between pixels -Camera-Computer interfaces.

##### UNIT-II: LOW-LEVEL VISION

(9 Periods)

Image representation–Gray level transformations, Histogram, Image subtraction, Image averaging – Filters: Smoothing spatial filters, sharpening spatial filters, smoothing frequency domain filters, sharpening frequency domain filters-Edge detection.

##### UNIT-III: HIGHER LEVELVISION:

(9 Periods)

Segmentation-Edge linking and Boundary Detection, Thresholding, Region-oriented segmentation, the use of motion Description: Boundary Descriptors, Regional Descriptors, Recognition: Decision-Theoretic methods, structural methods.

##### UNIT-IV: SENSORS IN ROBOTICS

(9 Periods)

Position sensors - optical, non-optical, Velocity sensors, Accelerometers, Proximity Sensors - Contact, non-contact, Range Sensing, touch and Slip Sensors, Force and Torque Sensors. Different sensing variables - smell, Heat or Temperature, Humidity, Light, Speech or Voice recognition Systems, Telepresence and related technologies, robot control through vision

**UNIT-V:ROBOT VISION****(9 Periods)**

Robotic operating System (ROS) -Introduction, Real and Simulated Robots; Introduction to OpenCV, Open NI and PCL, installing and testing ROS camera Drivers, ROS to OpenCV – The CV\_bridge Package.

**Total Periods: 45**

**Topics for self-study are provided in the lesson plan**

**TEXTBOOKS:**

1. K.S.Fu, R.C.Gonzalez, CSG.Lee, *-Robotics control, sensing, vision and Intelligencell*, McGraw Hill EducationPvt.Ltd.,2017.
2. Richard D. Klafter, Thomas A. Chmielewski, Michael Negin,*Robotics Engineering: An Integrated Approach*, PHI Learning, New Delhi, 2009.

**REFERENCEBOOKS:**

1. Damian M.Lyons,*Cluster Computing for Robotics and Computer Vision*,World Scientific, Singapore, 2011.
2. Rafael C.Gonzalez, Richard E.Woods, StevenL. Eddins, *Digital Image Processing using MATLAB* ,2<sup>nd</sup> edition, Tata McGrawHill, 2010.
3. Carsten Steger, Markus Ulrich, Christian Wiedemann, *-Machine Vision algorithms and Applications*, WILEY-VCH, Weinheim, 2008.
4. Kenneth Dawson-Howe, *-A Practical Introduction to Computer Vision with OpenCV*, Wiley, Singapore, 2<sup>nd</sup> edition, 2013.

## **MINOR DEGREE IN SUSTAINABLE ENGINEERING**

**Offering Department:** CIVIL ENGINEERING

**Students of Eligible Branches:** CSE, CSSE, IT,ECE, EEE, EIE and ME

### **COURSE STRUCTURE**

Year & Semester	Course Code	Course Title	Contact Periods per week				C	Scheme of Examination Max. Marks		
			L	T	P	Total		Int. Marks	Ext. Marks	Total Marks
III B.Tech. I-Sem (2 Theory)	19BM50101	Sustainable Engineering*	3	-	-	3	3	40	60	100
	19BM50102	Ecology and Environmental Impact	3	-	-	3	3	40	60	100
	19BM50103	Waste to Energy	3	-	-	3	3	40	60	100
III B.Tech. II-Sem (2 Theory)	19BM60101	Environmental Sustainability	3	-	-	3	3	40	60	100
	19BM60102	Sustainable Energy Systems	3	-	-	3	3	40	60	100
	19BM60103	Sustainability in The Built Environment	3	-	-	3	3	40	60	100
IV B.Tech. I-Sem (2 Theory)	19BM70101	Environmental Economics	3	-	-	3	3	40	60	100
	19BM70102	Sustainable Cities	3	-	-	3	3	40	60	100
	19BM70103	Sustainable Design of Technology Systems	3	-	-	3	3	40	60	100

\*Compulsory Course if not studied in major degree

**Note:** If any student has chosen a course from the above list in their regular curriculum then, he/she is not eligible to opt the same course/s for the Minor degree. It is the responsibility of the student to acquire/complete prerequisite before taking the respective course.

### III B.Tech. - I Semester

#### (19BM50101) SUSTAINABLE ENGINEERING

Int. Marks	Ext. Marks	Total Marks	L	T	P	C
40	60	100	3	-	-	3

#### PRE-REQUISITES: -

**COURSE DESCRIPTION:** Principles of sustainability; Sustainability metrics and assessment tools; Sustainable engineering practices; Sustainable engineering applications; Sustainable urbanization and industrialization.

**COURSE OUTCOMES:** *After successful completion of the course, students will be able to:*

- CO1. Analyze the principles of sustainability to solve complex environmental problems following relevant standards/protocols considering society, health, safety and environment.
- CO2. Analyze sustainability metrics and assessment tools to solve complex environmental problems following relevant standards and emerging trends considering society, health, safety, environment and economics besides communicating effectively in graphical form.
- CO3. Analyze sustainable engineering practices to solve complex environmental problems using appropriate tools and techniques following relevant standards considering society, health, safety, environment, economics and management besides communicating effectively in graphical form.
- CO4. Design sustainable engineering applications to solve complex environmental problems using appropriate tools and techniques following relevant standards considering society, health, safety, environment, economics and management besides communicating effectively in graphical form.
- CO5. Analyze sustainable urbanization and industrialization principles to solve complex environmental problems using appropriate tools and techniques following relevant standards considering society, health, safety, environment, economics and management besides communicating effectively in graphical form.

#### DETAILED SYLLABUS:

##### UNIT - I: PRINCIPLES OF SUSTAINABILITY

(09 Periods)

Emerging challenges, Sustainability and sustainable engineering; Environmental concerns; Social, economic and legal issues; Availability and depletion of natural resources, Disaster resiliency; Multilateral environmental agreements – Basel convention, Clean development mechanism (CDM), Montreal and Kyoto protocols.

##### UNIT – II: SUSTAINABILITY METRICS AND ASSESSMENT TOOLS (09 Periods)

Sustainability indicators, metrics and assessment tools, Material flow analysis and material budget, Carbon footprint analysis, Life cycle assessment, Streamlined life-cycle assessment (SLCA), Economic input output-life cycle analysis, Environmental health risk assessment, Other emerging assessment tools.

**UNIT - III: SUSTAINABLE ENGINEERING PRACTICES (09 Periods)**

Sustainable energy engineering, Sustainable waste management, Green and sustainable buildings and infrastructure, Sustainable civil infrastructure, Sustainable remediation of contaminated sites, Climate geoengineering.

**UNIT - IV: SUSTAINABLE ENGINEERING APPLICATIONS (09 Periods)**

Environmental and chemical engineering projects, Materials engineering projects, Infrastructure engineering projects – Background, Methodology, Goal and Scope, Study area, Technical design, Environmental sustainability, Life cycle assessment, Economic sustainability, Social sustainability, Rating systems – ENVISION, LEED, GRIHA, IGBC; Conclusions.

**UNIT – V: SUSTAINABLE URBANIZATION AND INDUSTRIALIZATION (09 Periods)**

Sustainable urbanization and industrialization, United Nations sustainable development goals – Right to education, Poverty eradication, Social and technological changes; Industrial Processes - Material selection, Energy efficiency, Pollution prevention and control techniques, Industrial Ecology, Industrial symbiosis.

**Total Periods: 45**

**Topics for self-study are provided in the lesson plan.**

**TEXT BOOKS:**

1. Reddy, K. R., Cameselle, C., and Adams, J. A., *Sustainable Engineering: Drivers, Metrics, Tools, and Applications*, John Wiley & Sons, Inc., Hoboken, New Jersey, 2019,
2. Allen, D. T. and Shonnard, D. R., *Sustainability Engineering: Concepts, Design and Case Studies*, Pearson Education, 1<sup>st</sup> Edition, 2012.

**REFERENCE BOOKS:**

1. Bradley. A. S; Adebayo, A. O., Maria, P., *Engineering Applications in Sustainable Design and Development*, Cengage Learning, 1<sup>st</sup> Edition, 2016.
2. Purohit, S. S., *Green Technology: An Approach for Sustainable Environment*, Agrobios Publication, 1<sup>st</sup> Edition, 2016.
3. *Energy Conservation Building Code (ECBC) 2007*, Bureau of Energy Efficiency, Govt. of India, New Delhi.
4. Twidell, J. W. and Weir, A. D., *Renewable Energy Resources*, Routledge, Taylor & Francis Group, 3<sup>rd</sup> Edition, 2015.

**ADDITIONAL LEARNING RESOURCES:**

1. Daniel A. Vallero and Chris Brasier, *Sustainable Design: The Science of Sustainability and Green Engineering*, Wiley-Blackwell, 1<sup>st</sup> Edition, 2008.
2. Jorge A. Vanegas, *Sustainable Engineering Practice: An Introduction*, Committee on Sustainability, American Society of Civil Engineers, <https://doi.org/10.1061/9780784407509>, 2004.
3. Mackenthun, K. M., *Basic Concepts in Environmental Management*, CRC Press, Taylor & Francis Group, 1<sup>st</sup> Edition, 1999.
4. *Environment Impact Assessment Guidelines*, Notification of Government of India, 2006.

### III B.Tech. - I Semester

#### (19BM50102) **ECOLOGY AND ENVIRONMENTAL IMPACT**

Int. Marks	Ext. Marks	Total Marks	L	T	P	C
40	60	100	3	-	-	3

**PREREQUISITES:** Course on Environmental Science

**COURSE DESCRIPTION:** Ecology; Ecosystem; Ecological impact assessment, Ecotoxicology and bio-monitoring, Restoration ecology.

**COURSE OUTCOMES:** *On successful completion of this course, the students will be able to:*

- CO1 Demonstrate the basic knowledge on ecology to provide solutions to environmental problems using appropriate tools and techniques considering society, health, environment and sustainability besides communicating effectively in graphical form.
- CO2 Analyze the ecosystems to solve environmental problems using appropriate tools and techniques considering society, health, safety, environment and sustainability besides communicating effectively in graphical form.
- CO3 Analyze the ecological impact assessment to solve complex environmental problems using appropriate tools and techniques following relevant standards and norms considering society, health, safety, environment, sustainability and economics besides communicating effectively in graphical form.
- CO4 Analyze the eco-toxicology effects and bio-monitoring of ecosystems to solve complex environmental problems using appropriate tools and techniques following relevant standards and norms considering society, health, safety, environment, sustainability and project management besides communicating effectively in graphical form.
- CO5 Analyze ecology of disturbed ecosystems, reconstructions and restoration of natural ecosystems to solve complex environmental problems following relevant standards and latest developments considering society, health, safety, environment, sustainability and project management besides communicating effectively in graphical form.

#### **DETAILED SYLLABUS:**

##### **UNIT - I: ECOLOGY**

**(10 Periods)**

Scope, concept and multidisciplinary nature of ecology; Organizational level of ecological systems, Abiotic and biotic environment, Limiting factors, Adaptation, Habitat and niche, Holocoenotic nature of environment, Concept of biosphere; Landscape, population and community ecology; Synecological principles, Species area relations, Methods of sampling and describing plant community, Ecological succession, Succession models, Concept of climax.

##### **UNIT - II: ECOSYSTEM**

**(8 Periods)**

Structure and function of ecosystems, Productivity, Decomposition, Energy flow, Ecological efficiencies, Ecological pyramids, Global pattern of productivity, Nutrient cycling (Carbon, Nitrogen and Phosphorus), Ecosystem stability – Inertia, Resilience; Fragile ecosystem, Hot spots, Ecosystem services, Net Present Value (NPV) of ecosystems, Major biomes of India and the world.

**UNIT - III: ECOLOGICAL IMPACT ASSESSMENT (09 Periods)**

Principles and practices of ecological assessment, Carrying capacity of environment and earth, Environmental quality, Ecological and social impact of man, Resource depletion, Loss of biological diversity, Land degradation and deforestation, Impact assessment methods through case studies at organism, Community and ecosystem levels, Detailed criteria, Survey methods and evaluation, Cost benefit analysis, Prediction of impacts on physical environment and biotic communities through modelling, Developing impact statement.

**UNIT - IV: ECOTOXICOLOGY AND BIO-MONITORING (08 Periods)**

**Ecotoxicology:** Ecotoxicology - Background, importance and measurement; LC50, EC50, NOEC, LOEC, Toxic units, Ecosystem response to de-oxygenation; Eutrophication - Kinetics, Lake phosphorous model, Pesticides.

**Bio-monitoring:** Bio-monitoring, Active and passive monitoring, Concept of bioaccumulation, Bio-indicator parameters, Bio-air conditioning and bio-purifiers, Pollution tolerance index of plants, Green belt development, Plant protection and protective substances to pollution stress, Data-gathering techniques, Organization of the survey and data analysis.

**UNIT - V: RESTORATION ECOLOGY (10 Periods)**

Ecological theories and principles that guide restoration practices in a variety of ecosystems, Causes of ecosystem degradation, Motivations for restoration, Factors that influence success in restoration; Ecology of disturbed ecosystems - Disturbance and its impact on the structure and functioning of terrestrial and aquatic ecosystems; Aims and strategies of restoration - Concepts of restoration, Single vs. multiple end-points, Ecosystem reconstructions, Physical, chemical, biological and biotechnological tools of restoration; Restoration of biological diversity - Acceleration of ecological succession, Reintroduction of biota; Degradation and restoration of natural ecosystems - Rivers, Wetlands, Forests, Grassland, Savanna, Aquatic; Restoration of degraded soils - Restoration of contaminated soils and soil fertility, Mine spoil restoration.

**Total Periods: 45**

**Topics for self-study are provided in the lesson plan.**

**TEXT BOOKS:**

1. Saha, T. K., *Ecology and Environmental Biology*, Books and Allied (P) Ltd., Kolkata, 1<sup>st</sup> Edition, 2010.
2. Walker, C. H., Hopkin, S. P., Sibly R. M. and Peakall, D. B., *Principles of Ecotoxicology*, Taylor and Francis Group, London, 2<sup>nd</sup> Edition, 2004.
3. Palmer, M. A., Zedler, J. B. and Falk, D. A., *Foundations of Restoration Ecology*, Island Press, USA, 2016.

**REFERENCE BOOKS:**

1. Dash, M. C. and Dash, S. P., *Fundamentals of Ecology*, Tata - McGraw Hill, New Delhi, 3<sup>rd</sup> Edition, 2001.
2. Smith, T. M. and Smith, R. L., *Elements of Ecology*, Pearson Education Ltd., England, 9<sup>th</sup> Edition, 2015.
3. Hughes, W., *Essentials of Environmental Toxicology*, Taylor & Francis Press, USA, 2005.
4. Wathern, P., and Hynman, U., *Impact Assessment and Sustainable Resource Management-Theory and Practice*, Routledge Press, 2014.
5. Westman, W. E., *Ecology, Impact Assessment and Environmental Planning*, John Wiley, New York, 1985.

**ADDITIONAL LEARNING RESOURCES:**

1. Rajgopalan, R., *Environment and Ecology - A Complete Guide*, OakBridge Publishing, 2<sup>nd</sup> Edition, 2019.
2. Charles J. Krebs, *Ecology: The Experimental Analysis of Distribution and Abundance*, Pearson Education India, 6<sup>th</sup> Edition, 2008.
3. Mani, M., Ganesh, L.S. and Varghese, K., *Sustainability and Human Settlements*, Sage Publications, New Delhi, 1<sup>st</sup> Edition, 2005.



### III B.Tech. - I Semester

#### (19BM50103) WASTE TO ENERGY

Int. Marks	Ext. Marks	Total Marks	L	T	P	C
40	60	100	3	-	-	3

**PRE-REQUISITES:** Course on Environmental Science.

**COURSE DESCRIPTION:**Waste to energy concept; Municipal solid waste; Thermochemical waste to energy technologies; Biological waste to energy technologies; Waste to energy plants and the environment.

**COURSE OUTCOMES:** On successful completion of this course, the students will able to:

- CO1 Analyze waste to energy process to solve waste management challenges using appropriate tools and techniques, following relevant codes, regulations and latest developments considering society, environment, sustainability and economics besides communicating effectively in graphical form.
- CO2 Analyze municipal solid waste characteristics and sampling techniques to solve solid waste management challenges using appropriate tools and techniques, following relevant codes, regulations and latest developments considering society, environment, sustainability and economics besides communicating effectively in graphical form.
- CO3 Analyze thermochemical waste to energy technologies to solve solid waste management challenges using appropriate tools and techniques, following relevant codes, regulations and latest developments considering society, environment, sustainability and economics besides communicating effectively in graphical form.
- CO4 Analyze traditional and advanced biological technologies for converting waste to energy using appropriate tools and techniques, following relevant codes, regulations and latest developments considering society, environment, sustainability and economics besides communicating effectively in graphical form.
- CO5 Analyze energy plants and the environment to solve waste to energy challenges using appropriate tools and techniques, following relevant codes, regulations and latest developments considering society, environment, sustainability and economics besides communicating effectively in graphical form.

#### **DETAILED SYLLABUS:**

##### **UNIT - I: WASTE TO ENERGY CONCEPT (09 Periods)**

Waste to energy- A historical prospective, Waste as a renewable resource, Global production of power from waste; The politics of waste - Waste management hierarchy, Circular economy/zero Waste, Energy from waste with the circular economy concept.

##### **UNIT - II: MUNICIPAL SOLID WASTE (08 Periods)**

Sources and types of solid waste, Quantity, Factors affecting generation of solid waste, Characteristics, Waste classification, Methods of sampling and characterization, Energy content of the waste.

##### **UNIT - III: THERMOCHEMICAL WASTE TO ENERGY TECHNOLOGIES (10 Periods)**

Traditional waste combustion technologies - Waste processing and treatment facility, Rotary combustors, Fluidized bed combustors; Energy production from waste through advanced thermochemical techniques - Incineration, Gasification and Pyrolysis.

**UNIT - IV: BIOLOGICAL WASTE TO ENERGY TECHNOLOGIES (10 Periods)**

Energy production from waste through biological techniques - Anaerobic digestion, Fermentation, Transesterification, Advanced microbial fuel cells; Cultivation of algal biomass from wastewater and energy production from algae.

**UNIT - V: WASTE TO ENERGY PLANTS AND THE ENVIRONMENT (08 periods)**

Emission limits for waste combustion, Environmental politics and science, Waste to energy plant cost, Latest developments in waste to energy, Case Studies.

**Total Periods: 45**

***Topics for self-study are provided in the lesson plan.***

**TEXT BOOKS:**

1. Breeze, Paul, *Energy from Waste*, Academic Press, 1<sup>st</sup> Edition, 2017.
2. Singh, R. P., Prasad, V. and Vaish, B., *Advances in Waste-to-Energy Technologies*, CRC Press, 1<sup>st</sup> Edition, 2019.

**REFERENCE BOOKS:**

1. Maczulak, A. E., *Environmental Engineering: Designing a Sustainable Future*, Infobase Publishing, 4<sup>th</sup> Edition, 2010.
2. Kalogirou, E. N., *Waste-to-Energy Technologies and Global Applications*, CRC Press, 1<sup>st</sup> Edition, 2017.
3. Klinghoffer, N. B., & Castaldi, M. J., *Waste to Energy Conversion Technology*, Elsevier, 3<sup>rd</sup> Edition, 2013.

**ADDITIONAL LEARNING RESOURCES:**

1. Rogoff, M. J., & Screve, F., *Waste-to-energy: Technologies and Project Implementation*, Academic Press, 1<sup>st</sup> Edition, 2019.
2. Trabold, T., and Babbitt, C. W., *Sustainable Food Waste-to-Energy Systems*, Academic Press, 1<sup>st</sup> Edition, 2018.

### III B.Tech. - II Semester

#### (19BM60101) ENVIRONMENTAL SUSTAINABILITY

Int. Marks	Ext. Marks	Total	L	T	P	C
40	60	100	3	-	-	3

**PREREQUISITES:** Course on Environmental Science, Sustainable Engineering

**COURSE DESCRIPTION:** Environmental measurements from different disciplines and sustainability concepts; Environmental chemistry and physical process in environment; Environmental risk assessments with concepts of EIA and LCA; Sustainability assessment of water and wastewater treatment; Sustainability assessment of solid waste management and air pollution issues.

**COURSE OUTCOMES:** On successful completion of this course, the students will be able to:

- CO1 Analyze environmental measurements and sustainability concepts to solve environmental sustainability challenges using appropriate tools and techniques, following relevant codes, regulations and latest developments considering society, environment, sustainability and economics besides communicating effectively in graphical form.
- CO2 Analyze environmental chemistry and physical processes to solve environmental sustainability challenges using appropriate tools and techniques, following relevant codes, regulations and latest developments considering society, environment, sustainability and economics besides communicating effectively in graphical form.
- CO3 Analyze environmental risk assessment with concepts of EIA and LCA to solve environmental sustainability problems using appropriate tools and techniques following relevant codes and latest developments considering society, environment, sustainability and economics besides communicating effectively in graphical form.
- CO4 Analyze water and wastewater treatment to solve environmental sustainability problems using appropriate tools and techniques, following relevant codes, regulations and latest developments considering health, society, environment, sustainability and economics besides communicating effectively in graphical form.
- CO5 Analyze sustainable assessment of solid waste management and air pollution issue to solve complex problems using appropriate tools and techniques, following relevant codes, regulations and latest developments considering health, society, environment, sustainability and economics besides communicating effectively in graphical form.

#### **DETAILED SYLLABUS:**

#### **UNIT – I: ENVIRONMENTAL MEASUREMENTS FROM DIFFERENT DISCIPLINES AND SUSTAINABILITY CONCEPTS (09 Periods)**

Environmental measurements - Mass concentration units, Partial pressure units, Other types of units, Qualitative and quantitative measurements; Sustainability concepts and evolution, Engineering for sustainability.

**UNIT – II: ENVIRONMENTAL CHEMISTRY AND PHYSICAL PROCESS IN ENVIRONMENT (09 Periods)**

Environmental chemistry, Mass balance and reactor systems; Mass balance in continuous reactor, continuous stirred tank reactor (CSTR) and Plug flow reactor; Plug flow reactor and energy flow, Energy balance and earth overshoot day, Mass transport processes.

**UNIT – III: ENVIRONMENTAL RISK ASSESSMENT WITH CONCEPTS OF EIA AND LCA (09 Periods)**

Life Cycle Assessment (LCA); Environmental Impact Assessment (EIA) - Fundamentals, Evolution of EIA (Global and Indian Scenario), Elements of EIA– Screening, Scoping, Public consultation, Environmental clearance process in India - Key elements in 2006 EIA (Govt. of India) notification; Environmental risk, Environmental impact calculation by using LCA technique, Risk assessments with concepts of EIA and LCA, Case studies.

**UNIT – IV: SUSTAINABILITY ASSESSMENT OF WATER AND WASTEWATER TREATMENT (08 Periods)**

Sustainability assessment in Water purification – Processes, Engineered systems – Aeration, Solids separation, Settling operations, Coagulation, Softening, Filtration, Disinfection; Sustainability assessment in wastewater treatment process and disposal – Primary, Secondary and Tertiary.

**UNIT – V: SUSTAINABILITY ASSESSMENT OF SOLID WASTE MANAGEMENT AND AIR POLLUTION ISSUES (10 Periods)**

Sustainability assessment of solid waste management –Need and scope; Municipal solid waste – Types, Composition and characteristics; Methods of collection and transportation; Methods of disposal – Open dumping, Sanitary landfill, Composting and Incineration; Utilization - 6R Concept; Sustainability assessment of air pollution issues – Need and scope, Classification, Sources – Line, Area, Stationary, Mobile; Effects of air pollutants on man, Material and vegetation; Global effects of air pollution.

**Total Periods: 45**

**Topics for self-study are included in the lesson plan.**

**TEXT BOOKS:**

1. Davis, M. L. and Cornwell, D. A., *Introduction to Environmental Engineering*, McGraw-Hill, 5<sup>th</sup> Edition, 2008.
2. Keong, Choy Yee, *Global Environmental Sustainability: Case Studies and Analysis of the United Nations' Journey toward Sustainable Development*, Elsevier, 2020.

**REFERENCE BOOKS:**

1. Singh, Ritu, and Sanjeev Kumar, *Green Technologies and Environmental Sustainability*, Springer, 2<sup>nd</sup> Edition, 2017.
2. Joumard, Robert, and Henrik Gudmundsson, *Indicators of Environmental Sustainability in Transport: An Interdisciplinary Approach to Methods*, European Commission, 2<sup>nd</sup> Edition, 2010.
3. Smith, Fraser, *Environmental Sustainability: Practical Global Applications*, CRC Press, 1<sup>st</sup> Edition, 2020.

**ADDITIONAL LEARNING RESOURCES:**

1. Burke, G., Singh, B. R. and Theodore, L., *Handbook of Environmental Management and Technology*, John Wiley & Sons, 2nd Edition, 2000.
2. Peavy, Howard S., Donald R. Rowe, and George Tchobanoglous, *Environmental Engineering*, McGraw-Hill, Indian Edition, 1st Edition, 2017.

### III B.Tech. - II Semester

#### (19BM60102) SUSTAINABLE ENERGY SYSTEMS

Int. Marks	Ext. Marks	Total Marks	L	T	P	C
40	60	100	3	-	-	3

**PREREQUISITES:** Courses on Environmental Science, Sustainable Engineering

**COURSE DESCRIPTION:** The energy landscape and sustainability; Solar and wind energy; Biomass, geothermal, tidal and wave energies; Electricity storage technologies; Grid integration of renewable energy.

**COURSE OUTCOMES:** On successful completion of this course, the students will be able to:

- CO1 Analyze the energy landscape and sustainability to provide solutions to energy problems using appropriate tools and techniques following relevant standards considering society, health and environment besides communicating effectively in graphical form.
- CO2 Analyze solar and wind energy systems to solve the complex energy problems using appropriate tools and techniques following relevant standards considering society, health, environment, sustainability and economics besides communicating effectively in graphical form.
- CO3 Analyze biomass, geothermal, tidal and wave energy systems to solve the complex energy problems using appropriate tools and techniques following relevant standards considering society, health, environment, sustainability and economics besides communicating effectively in graphical form.
- CO4 Analyze electric storage technology systems to solve the complex energy problems using appropriate tools and techniques following relevant standards and latest developments considering society, health, environment, sustainability and economics besides communicating effectively in graphical form.
- CO5 Analyze grid integration of renewable energy to solve the complex energy problems using appropriate tools and techniques following relevant standards considering society, health, environment, sustainability and economics besides communicating effectively in graphical form.

#### DETAILED SYLLABUS:

##### UNIT - I: THE ENERGY LANDSCAPE AND SUSTAINABILITY (09 Periods)

Current global energy use, National and international energy consumption and related greenhouse gas emissions, Lifetime of fossil fuels, Sustainability and energy use, Energy conversion technologies, Energy forms and conversion, First and second laws of thermodynamics and efficiencies; Devices - Heat engines, Refrigerators, Heat pumps; Instantaneous and average power.

##### UNIT - II: SOLAR AND WIND ENERGY (09 Periods)

Principles of solar radiation, Resource foundations, Technology challenges, Sustainability, Solar energy industry and economics, Net Metering; Origin of the wind, Power in the wind, Wind resource basics, Wind energy technologies, Challenges, Sustainability, Wind energy Industry.

##### UNIT - III: BIOMASS, GEOTHERMAL, TIDAL AND WAVE ENERGIES (09 Periods)

Sources of feedstocks; Biofuels - Bioethanol, Biodiesel, Algal, Jatropha and Biogas; Conversion technology, Diesel and ethanol, Biogas, Electricity production, Transportation, Challenges, Sustainability, Economics; Geothermal energy - Principles, Geothermal potential and technology, Electricity production, Conversion technology,

Challenges, Economics; Tidal and wave energies, Conversion technologies, Sustainability.

**UNIT - IV: ELECTRICITY STORAGE TECHNOLOGIES (09 Periods)**

Introduction, Battery energy storage technologies - Lithium-ion batteries, Full cells, Nickel-based batteries, Lead-acid batteries, Sodium-sulfur batteries; Hydro energy storage - Applications of pump hydro energy storage plant, Site selection for pump hydro energy storage plant; Thermal energy storage, Capacitors and applications, Latest developments.

**UNIT - V: GRID INTEGRATION OF RENEWABLE ENERGY (09 Periods)**

Variability, Intermittency and dispatchability, Electric grid infrastructure, Integrating renewable energy into the grid, Growing a more efficient grid, The smart grid, Secure communication in the smart grid; Cogeneration plant and power distribution in industry, Micro grids.

**Total Periods: 45**

**Topics for self-study are provided in the lesson plan.**

**TEXT BOOKS:**

1. Boyle, Godfrey, *Renewable Energy: Power for a Sustainable Future*, Oxford University Press, 3<sup>rd</sup> Edition, 2012.
2. Jefferson W. Tester, Elisabeth M. Drake, Michael J. Driscoll, Michael W. Golay, William A. Peters, *Sustainable Energy (Choosing Among Options)*, MIT Press, 2<sup>nd</sup> Edition, 2012.

**REFERENCE BOOKS:**

1. Gilbert M. Masters, *Renewable and Efficient Electric Power Systems*, John Wiley & Sons, Inc., Hoboken, New Jersey, 2<sup>nd</sup> Edition, 2013.
2. Vanek, F.M., Albright, L.D., *Energy Systems Engineering - Evaluation and Implementation*, McGraw-Hill, 2<sup>nd</sup> Edition, 2008.
3. David MacKay, *Sustainable Energy: Without the Hot Air*, UIT Cambridge Ltd., Cambridge, England, 2009.
4. Frank Kreith, *Principles of Sustainable Energy Systems*, , CRC Press, Taylor and Francis group, 2<sup>nd</sup> Edition, 2014.

**ADDITIONAL LEARNING RESOURCES:**

1. Richter Burton, *Beyond Smoke and Mirrors: Climate Change and Energy in the 21<sup>st</sup> Century*, Cambridge University Press, New York, 2010.

### III B.Tech. - II Semester

#### (19BM60103) SUSTAINABILITY IN THE BUILT ENVIRONMENT

Int. Marks	Ext. Marks	Total Marks	L	T	P	C
40	60	100	3	-	-	3

**PRE-REQUISITES:** Courses on Environmental Science, Sustainable Engineering.

**COURSE DESCRIPTION:** Sustainable urban development; Sustainable site planning and analysis; Sustainable buildings; Building envelope and services; Management of sustainable built environment.

**COURSE OUTCOMES:** On successful completion of this course, the students will be able to:

- CO1 Analyze sustainable urban development to solve problems associated with the built environment using appropriate tools and techniques following relevant standards considering society, health and environment besides communicating effectively in graphical form.
- CO2 Analyze sustainable site planning to solve complex problems associated with the built environment using appropriate tools and techniques following relevant standards considering society, health and environment besides communicating effectively in graphical form.
- CO3 Analyze sustainable buildings to solve complex problems associated with the built environment using appropriate tools and techniques following relevant standards considering society, health and environment besides communicating effectively in graphical form.
- CO4 Analyze building envelope and services to solve complex problems associated with the built environment using appropriate tools and techniques following relevant standards considering society, health and environment besides communicating effectively in graphical form.
- CO5 Analyze management of sustainable built environment to solve complex problems using appropriate tools and techniques following relevant standards considering society, health and environment besides communicating effectively in graphical form.

#### **DETAILED SYLLABUS:**

##### **UNIT-I: SUSTAINABLE URBAN DEVELOPMENT (09 Periods)**

Urban development - Human activities and their effects; Carbon cycle; Role of construction material such as concrete and steel; CO<sub>2</sub> contribution from cement and other construction materials; GHG emissions - Global climate change; Efforts in sustainable development and construction - Universal efforts, International organizations involved.

##### **UNIT - II: SUSTAINABLE SITE PLANNING AND ANALYSIS (09 Periods)**

Sustainable site planning, Principles of site analysis, Improving sustainability of a site – Stormwater, Reducing site disturbance, Vegetation; Site analysis - Examples of site analysis; Introduction to alternative energy - Solar, Wind, Hydro, Biofuel etc.

##### **UNIT - III: SUSTAINABLE BUILDINGS (09 Periods)**

Introduction to sustainable buildings and standards, Green buildings, Energy efficiency and sustainability; Passive House; Net Zero Energy Buildings (NZEB), Examples of different types of NZEB.

**UNIT - IV: BUILDING ENVELOPE AND SERVICES (09 Periods)**

Building envelope effect and energy efficiency measures, Renewable energy integration, Sustainable building services, Sustainable construction and materials, Integrated design, Energy use and CO<sub>2</sub>, Built environment - Aging and susceptibility to natural disasters.

**UNIT – V: MANAGEMENT OF SUSTAINABLE BUILT ENVIRONMENT (09 Periods)**

Life cycle planning, Measuring sustainability; Facilities management - Waste management, Improved amenities, Improved transport infrastructure, Social mix, Accessibility issues, Cultural and historical issues.

**Total Periods: 45**

**Topics for self-study are provided in the lesson plan.**

**TEXT BOOKS:**

1. Alison Cotgrave and Mike Riley, *Total Sustainability in the Built Environment*, Macmillan Education, 1<sup>st</sup> Edition, 2012.
2. Kevin Lynch and Gary Hack, *Site Planning*, MIT Press, 3<sup>rd</sup> Edition, 1984.

**REFERENCE BOOKS:**

1. William McLean and Pete Silver, *Environmental Design Source Book: Innovative Ideas for a Sustainable Built Environment*, RIBA Publishing, 1<sup>st</sup> Edition, 2021.
2. Tim Dixon, John Connaughton, Stuart Green, *Sustainable Futures in the Built Environment to 2050: A Foresight Approach to Construction and Development*, John Wiley & Sons Ltd., 2018.
3. Rob Fleming, Saglinda H Roberts, *Sustainable Design for the Built Environment*, Routledge Press, London, 1<sup>st</sup> Edition, 2019.
4. Charles J. Kibert, *Sustainable Construction: Green Building Design and Delivery*, Wiley, 4<sup>th</sup> Edition, 2021.

**ADDITIONAL LEARNING RESOURCES:**

1. Mani, M., Ganesh, L.S. and Varghese, K., *Sustainability and Human Settlements*, Sage Publications, 1<sup>st</sup> Edition, 2005.
2. Barton, H., Grant, M., Guise, R., *Shaping Neighbourhoods: For Local Health and Global Sustainability*, Routledge Press, 2<sup>nd</sup> Edition, 2020.
3. <https://nptel.ac.in/courses/105/102/105102195/>
4. <https://nptel.ac.in/courses/124/107/124107011/>



## IV B.Tech. - I Semester

### (19BM70101) ENVIRONMENTAL ECONOMICS

Int. Marks	Ext. Marks	Total	L	T	P	C
40	60	100	3	-	-	3

**PREREQUISITES:** Courses on Environmental Science, Sustainable Engineering.

**COURSE DESCRIPTION:** Fundamentals of environmental economics; Economy and the natural environment interaction; Economic development and environment; Valuation of environmental goods and services; Sustainable economic development.

**COURSE OUTCOMES:** On successful completion of this course, the students will able to:

- CO1 Analyze fundamentals of environmental economics to solve environmental economics challenges associated with sustainable design of technology systems considering latest developments, society, environment, economic, and sustainability besides communicating effectively in graphical form.
- CO2 Analyze economy and the natural environment interaction to solve ecological limits and scarcity of eco-services approaches using different tools and techniques considering latest developments, relevant guidelines, environment and sustainability besides communicating effectively in graphical form.
- CO3 Analyze economic development and environment to solve environmental cost-benefit challenges using different tools and techniques considering latest developments, relevant guidelines, environment and sustainability besides communicating effectively in graphical form.
- CO4 Analyze valuation of environmental goods and services to solve methodical challenges using different tools and techniques considering latest developments, relevant guidelines, environment and sustainability besides communicating effectively in graphical form.
- CO5 Analyze sustainable economic development to solve environmental economics challenges using different tools and techniques considering latest developments, relevant guidelines, environment and sustainability besides communicating effectively in graphical form.

#### DETAILED SYLLABUS:

#### UNIT – I: FUNDAMENTALS OF ENVIRONMENTAL ECONOMICS (10 Periods)

Fundamentals of environmental economics, Review of microeconomics and welfare economics, Ecology-economy interaction, Perspective of economic modeling- the concept and conditions of sustainability of the human economy, Classification and characterization of resources and pollution as a public good or bad, Role of Externalities as the fundamental determinants, Property Rights, Market, Spatial-temporal dimensions of externality- command and control, Market approaches, Green tax, Taxes in controlling externalities

#### UNIT - II: ECONOMY AND THE NATURAL ENVIRONMENT INTERACTION

(08 Periods)

An overview of the economy and the natural environment; Interaction using an input-output based general equilibrium approach to show how ecological limits and scarcity of eco-services would affect the resource allocation and prices; Regimes of natural resources, Types of goods, Provision of public goods.

**UNIT – III: ECONOMIC DEVELOPMENT AND ENVIRONMENT (09 Periods)**

The relation between development environmental Quality - Environmental Kuznets curve; Development vs conservation of environmental resources - Ecosystem flips and irreversibility - Krutilla-Fisher equation; Environmental cost-benefit analysis under strong and weak conditions of sustainability; Choice of time discount rate for evaluation - Sustainability premium.

**UNIT – IV: VALUATION OF ENVIRONMENTAL GOODS AND SERVICES (10 Periods)**

Theory of environmental valuation and conceptual basis of its methods - Compensating variations and surplus, Equivalent variations and surplus, Willingness to pay or accept for improvement or loss of environmental goods and services; Empirical approaches in environmental valuation; Indirect methods of environmental valuation, Non-demand function methods of valuation, Revealed preference methods - (a) Hedonic Pricing, (b) Household production function approach, Defensive cost, Health cost and travel cost methods; The direct method of environmental valuation - Stated preference - Contingent valuation method.

**UNIT – V: SUSTAINABLE ECONOMIC DEVELOPMENT (08 Periods)**

Capital theoretic basis of the notion of sustainable development - Sustainable Development as non-declining intertemporal utility or that of the value of the wealth. Concepts of Genuine investment or savings, Green National Income, Natural capital stock and sustainable resource accounting, Strong and weak sustainability, Environmental adjustment of national income.

**Total Periods: 45**

**Topics for self-study are included in the lesson plan.**

**TEXT BOOKS:**

1. Siebert, H. and Siebert, H., *Economics of the Environment*. Massachusetts: Lexington Books, 9<sup>th</sup> Edition, 1981.
2. Pearce, David W., and Kerry Turner R., *Economics of Natural Resources and The Environment*, JHU Press, Revised and Enlarged Edition, 1990.

**REFERENCE BOOKS:**

1. Nick Hanley, Jason F Shorgen and Ben White, *Environmental Economics Theory and Practice*, MacMillan, 2<sup>nd</sup> Edition, 2006.
2. Tietenberg, Tom and Lynne Lewis, *Environmental and Natural Resource Economics*, Routledge, 11<sup>th</sup> Edition, 2018.
3. Kumar, P., *The Economics of Ecosystems and Biodiversity: Ecological and Economic Foundations*, Routledge, 2012.

**ADDITIONAL LEARNING RESOURCES:**

1. Field, C., *Environmental Economics: An Introduction*, McGraw-Hill Book Company (UK) Ltd, 8<sup>th</sup> Edition, 2021.
2. Sengupta, R., *Ecological Limits and Economic Development*, OUP Catalogue, 2013.

## IV B.Tech. - I Semester

### (19BM70102) SUSTAINABLE CITIES

Int. Marks	Ext. Marks	Total Marks	L	T	P	C
40	60	100	3	-	-	3

**PRE-REQUISITES:** Courses on Environmental Science, Sustainable Engineering.

**COURSE DESCRIPTION:** Sustainability and urban development; Functions of cities; Inclusive, Safe and productive cities; Sustainable urban services and infrastructure; Governing sustainable cities.

**COURSE OUTCOMES:** On successful completion of this course, the students will able to:

- CO1 Analyze sustainability and urban development to solve problems associated with cities using appropriate tools and techniques following relevant codes, regulations and latest developments considering society, environment, sustainability and economics besides communicating effectively in graphical form.
- CO2 Analyze city functioning for sustainability to solve problems associated with cities using appropriate tools and techniques, following relevant codes, regulations and latest developments considering society, environment, sustainability and economics besides communicating effectively in graphical form.
- CO3 Analyze inclusiveness, safety and productivity in cities to solve problems associated with cities using appropriate tools and techniques, following relevant codes, regulations and latest developments considering society, environment, sustainability and economics besides communicating effectively in graphical form.
- CO4 Analyze sustainable urban services and infrastructure to solve problems associated with cities using appropriate tools and techniques, following relevant codes, regulations and latest developments considering society, environment, sustainability and economics besides communicating effectively in graphical form.
- CO5 Analyze governance for sustainable cities to solve problems associated with cities using different tools and techniques considering latest developments, relevant guidelines, environment and sustainability besides communicating effectively in graphical form.

#### DETAILED SYLLABUS:

#### UNIT - I: SUSTAINABILITY AND URBAN DEVELOPMENT (08 Periods)

The urban opportunity; Cities - Cultural and social transformation; Challenge of urban politics, Planning and governance, Urban research methods, Urban theory and history, Urban development and the environment, Urban growth and the environment - Why cities grow?, Externalities and the environment, Urban economic restructuring, City size and settlement planning.

#### UNIT - II: FUNCTIONS OF CITIES (09 Periods)

Understanding urban systems, Municipal, Regional and national governance, Urban utilities, Urban public finance and taxation; Law, order and conflict; Land management and planning, Lessons from London and Mumbai.

#### UNIT - III: INCLUSIVE, SAFE AND PRODUCTIVE CITIES (10 Periods)

What is urban poverty?, Measuring urban poverty, Poverty reduction in cities, Affordable and adequate housing, Who can deliver the housing we need?, Safety and violence, Urban vulnerabilities; Making cities productive and reduce inequality- City production and consumption, Women in the informal economy, Migration, mobility and the urban-rural continuum Wealth and inequality, Case: SEWA, India, Migration and the refugee crisis; Improving human development in cities – Addressing the challenges of urban

public health, Solutions for improving urban health, Education and skills, Higher education in cities, Gender in the city, Human rights and justice, Law and equality, Apartheid in South African cities.

**UNIT - IV: SUSTAINABLE URBAN SERVICES AND INFRASTRUCTURE (08 Periods)**

Sustainable environmental services and infrastructure, Sustainable transport planning, ICT, Sustainable urban energy systems, Sustainable transport: Bangkok; How can cities be resilient -Air, water, food and natural resources; City risk exposure; Climate impacts, adaptation and mitigation; Building urban resilience, Environmental planning and the politics of change.

**UNIT - V: GOVERNING SUSTAINABLE CITIES (10 periods)**

Sustainable environmental practices, Urban disaster risk management, Post-disaster recovery, SDGs and other global processes, New institutions and governance, Public participation and democracy, Financing sustainable development, Measuring and monitoring the SDGs, Opportunities of secondary cities.

**Total Periods: 45**

**Topics for self-study are included in the lesson plan.**

**TEXT BOOKS:**

1. Al-Zu'bi, Maha, and Vesela Radovic, *SDG11-Sustainable Cities and Communities: Towards Inclusive, Safe, and Resilient Settlements*, Emerald Group Publishing, 1<sup>st</sup> Edition, 2019.
2. Rydin, Yvonne, *Governing for Sustainable Urban Development*, Earthscan, 2012.
3. Evans, Bob, Marko Joas, Susan Sundback, and Kate Theobald, *Governing Sustainable Cities*, Routledge, 2013.

**REFERENCE BOOKS:**

1. Register, R., *EcoCities: Rebuilding Cities in Balance with Nature*, New Society Publishers, Revised Edition, 2006.
2. Yigitcanlar, T, *Sustainable Urban and Regional Infrastructure Development: Technologies, Applications and Management: Technologies, Applications and Management*, IGI Global, 2007.

**ADDITIONAL LEARNING RESOURCES:**

1. Flint J. and Raco M., *The Future of Sustainable Cities: Critical Reflections*, Policy Press, 2<sup>nd</sup> Edition, 2012.
2. Corburn, J., *Toward the Healthy City: People, Places and the Politics of Urban Planning*, MIT Press, 3<sup>rd</sup> Edition, 2009.

## IV B.Tech. - I Semester

### (19BM70103) SUSTAINABLE DESIGN OF TECHNOLOGY SYSTEMS

Int. Marks	Ext. Marks	Total Marks	L	T	P	C
40	60	100	3	--	--	3

**PRE-REQUISITES:** Courses on Environmental Science, Sustainable Engineering.

**COURSE DESCRIPTION:** Sustainability and sustainable development; Product life cycle design – Methods and strategies; Product life cycle design – Software tools; Designing for sustainable product-service system – Methods and tools; Design for sustainability – Engineering design criteria and guidelines.

**COURSE OUTCOMES:** On successful completion of this course, the students will able to:

- CO1 Analyze sustainability and sustainable development to solve complex problems associated with sustainable design of technology systems using appropriate tools and techniques, following relevant codes, regulations and latest developments considering society, environment and economics besides communicating effectively in graphical form.
- CO2 Analyze product life cycle design methods and strategies to solve complex problems associated with sustainable design of technology systems using appropriate tools and techniques, following relevant codes, regulations and latest developments considering society, environment and economics besides communicating effectively in graphical form.
- CO3 Analyze product life cycle design software tools to solve complex problems associated with sustainable design of technology systems using appropriate tools and techniques, following relevant codes, regulations and latest developments considering society, environment and economics besides communicating effectively in graphical form.
- CO4 Design sustainable product-service systems to solve complex problems associated with sustainable design of technology systems using appropriate tools and techniques, following relevant codes, regulations and latest developments considering society, environment and economics besides communicating effectively in graphical form.
- CO5 Design engineering criteria and guidelines to solve complex problems associated with sustainable design of technology systems using appropriate tools and techniques, following relevant codes, regulations and latest developments considering society, environment and economics besides communicating effectively in graphical form.

#### **DETAILED SYLLABUS:**

#### **UNIT - I: SUSTAINABILITY AND SUSTAINABLE DEVELOPMENT (09 Periods)**

Sustainability and sustainable development - Understanding un-sustainability and need for Sustainability, Definitions, Pathway, Systems approach to design; Evolution of sustainability within design - Diverse approaches to design for sustainability, Relationship between approaches to design for sustainability and the application context.

#### **UNIT - II: PRODUCT LIFE CYCLE DESIGN – METHODS AND STRATEGIES**

**(08 Periods)**

Life Cycle Assessment (LCA) - Product Life Cycle Assessment, LCA introduction, LCA methodology, LCA goal, LCA scope, Inventory analysis, Impact assessment, Interpretation; Environmental risk, Environmental impacts calculation by using LCA technique, Risk assessment with concepts of LCA.

**UNIT - III: PRODUCT LIFE CYCLE DESIGN – SOFTWARE TOOLS (08 Periods)**  
History of product design by LCA with examples; ISO 14000, Life cycle analysis, SIMA PRO, LCA software and other software for LCA, LCA methodical challenges - Allocation and uncertainty, Sensitivity analysis.

**UNIT - IV: DESIGNING FOR SUSTAINABLE PRODUCT-SERVICE SYSTEM – METHODS AND TOOLS (10 Periods)**  
Sustainable product service system design – Definition, Types and examples; Sustainable product service system – Transition path and challenges, Sufficiency economy philosophy applied to sustainable product-service system (PSS) thinking, Khadi movement as a precursor to PSS thinking.

**UNIT - V: DESIGN FOR SUSTAINABILITY – ENGINEERING DESIGN CRITERIA AND GUIDELINES (09 periods)**  
Sustainable product-service system design applied to distributed economy, Other design for sustainability tools and approaches – Agriculture, Cities and communities, Carbon footprint, Green buildings, Green materials, Green energy, Sustainable development, Zero waste, Circular economy.

**Total Periods: 45**

***Topics for self-study are provided in the lesson plan.***

**TEXT BOOKS:**

1. Horne, Ralph, Tim Grant, and Karli Verghese, *Life Cycle Assessment: Principles, Practice and Prospects*, Csiro Publishing, 2009.
2. Bhamra, Tracy, and Vicky Lofthouse, *Design For Sustainability: A Practical Approach*. Routledge, 1<sup>st</sup> Edition, 2016.

**REFERENCE BOOKS:**

1. Vezzoli, C., Kohtala, C., Srinivasan, A., Diehl, J. C, Fusakul, S. M., Xin, L. and Sateesh, D., *Product-service System Design for Sustainability*, Routledge, 1<sup>st</sup> Edition, 2017.
2. Curran, Mary Ann, *Life Cycle Assessment Student Handbook*, John Wiley & Sons, 1<sup>st</sup> Edition, 2015.
3. Hauschild, Michael Z., Ralph K. Rosenbaum and Stig Irvin Olsen, *Life Cycle Assessment*, Springer International Publishing, 2018.
4. Hendrickson, Chris T., Lester B. Lave, and H. Scott Matthews, *Environmental Life Cycle Assessment of Goods and Services: An Input-Output Approach*. Routledge, 2010.

**ADDITIONAL LEARNING RESOURCES:**

1. Sharmistha Banerjee, *System Design for Sustainability*, IIT Guwahati, <https://nptel.ac.in/courses/107/103/107103081/>.
2. Curran, Mary Ann, *Life Cycle Assessment Handbook: A Guide for Environmentally Sustainable Products*, John Wiley & Sons, 3<sup>rd</sup> Edition, 2012.