



SREE VIDYANIKETHAN ENGINEERING COLLEGE
(AUTONOMOUS)

Sree Sainath Nagar, Tirupati

Department of Computer Science and Engineering

Supporting Document for 1.1.3

Courses having focus on
Employability/ Entrepreneurship/ skill Development

Program: B.Tech.- Computer Science and Engineering

Regulations : SVEC-19

The Courses (with course outcomes) under SVEC-19 Regulations which focus on ***employability/ entrepreneurship/ skill development*** are highlighted with the following colours.

Skill

Employability

Entrepreneurship

I B. Tech. - I Semester

(19BT1BS01) DIFFERENTIAL EQUATIONS AND MULTIVARIABLE CALCULUS

(Common to CE, ME, EEE, ECE, EIE, CSE, CSSE, IT, CSE (AI) and CSE (DS))

Int. Marks	Ext. Marks	Total Marks	L	T	P	C
40	60	100	3	1	-	4

PRE-REQUISITES: -

COURSE DESCRIPTION: Ordinary Differential Equations; Partial Differential Equations; Multivariable Calculus (Differentiation); Multivariable Calculus (Integration); Multivariable Calculus (Vector Calculus).

COURSE OUTCOMES: After successful completion of the course, students will be able to:

CO1: Formulate and solve differential equations by applying knowledge of calculus for engineering problems.

CO2: Demonstrate knowledge in multivariable calculus for evaluating multiple integrals through techniques of integration.

CO3: Identify scalar and vector valued functions and evaluate vector integrals through knowledge of vector integral theorems and techniques.

DETAILED SYLLABUS:

Unit I: Ordinary Differential Equations (9 Periods)

Second and higher order linear differential equations with constant coefficients: Non-Homogeneous equations with R.H.S terms of the type e^{ax} , $\sin ax$, $\cos ax$, polynomials in x , $e^{ax}V(x)$ and $xV(x)$; method of variation of parameters; Equations reducible to linear differential equations with constant coefficients: Cauchy's and Legendre's linear equations; Application to L-C-R Circuit problems.

Unit II: Partial Differential Equations (9 Periods)

Formation of PDE, solutions of first order linear and non-linear PDEs, Solution to homogenous and non-homogenous linear partial differential equations of second and higher order by complimentary function and particular integral method, method of separation of variables in Cartesian coordinates.

Unit III: Multivariable Calculus (Differentiation) (9 Periods)

Partial derivatives, Chain rule, Total derivative, Jacobian, Maxima and Minima of functions of two variables, Lagrange's method of undetermined multipliers.

Unit IV: Multivariable Calculus (Integration) (9 Periods)

Evaluation of Double integrals (Cartesian and polar coordinates), Change of order of integration (Cartesian form only); Evaluation of Triple integrals; Change of variables: double integration from Cartesian to polar coordinates, Triple integration from Cartesian to spherical and cylindrical polar coordinates; Areas enclosed by plane curves.

Unit V: Multivariable Calculus (Vector Calculus)**(9 Periods)**

Vector Differentiation: Scalar and Vector fields: Gradient of a scalar field, directional derivative, divergence of a vector field, solenoidal vector, curl of a vector field, irrotational vector, Laplacian operator. **Vector Integration:** Line integral-circulation-work done, Surface integral-flux and Volume integral; Vector integral theorems: Theorems of Green, Gauss and Stokes (without proofs).

Total Periods: 45

Topics for self-study are provided in the lesson plan

TEXT BOOKS:

1. T. K.V. Iyengar, B. Krishna Gandhi, S. Ranganatham and M.V.S.S.N. Prasad, *Engineering Mathematics, vol-1*, S. Chand and Company, 13th edition, 2014.
2. B. S. Grewal, *Higher Engineering Mathematics*, Khanna publishers, 44th edition, 2017.

REFERENCE BOOKS:

1. Dennis G. Zill and Warren S. Wright, *Advanced Engineering Mathematics*, Jones and Bartlett, 6th edition, 2011.
2. R. K. Jain and S. R. K. Iyengar, *Advanced Engineering Mathematics*, Alpha Science International Ltd., 6th edition, 2017.

I B. Tech. - I Semester

(19BT1BS04) ENGINEERING CHEMISTRY

(Common to CE, ME, CSE, CSSE and IT)

Int. Marks	Ext. Marks	Total Marks	L	T	P	C
40	60	100	3	-	-	3

PRE-REQUISITES: -

COURSE DESCRIPTION: Atomic Structure and Bonding Theories; Water Treatment; Electrochemistry and Applications; Corrosion; Instrumental Methods and Applications; Fuel chemistry and Lubricants.

COURSE OUTCOMES: After successful completion of the course, students will be able to:

- CO1. Apply the basic knowledge of quantum mechanical approach to atomic structure and bonding theories to identify shapes of different orbitals and molecules.
- CO2. Analyze and solve problems associated with hardness of water, boiler troubles and address the societal, health and safety issues related to quality of water.
- CO3. Apply the basic knowledge of corrosion phenomenon to identify solutions for control of corrosion and demonstrate competency in the basic concepts of electrochemical cells.
- CO4. Demonstrate the basic knowledge of instrumental methods and their applications in the structural analysis of materials.
- CO5. Apply the basic knowledge of fuel chemistry and lubricants to identify the quality of fuels and lubricants.

DETAILED SYLLABUS:

Unit I: Atomic Structure and Bonding Theories

(9Periods)

Quantum-mechanical model of atom, Schrodinger wave equation, significance of Ψ and Ψ^2 , applications to particle in a box and hydrogen atom; Molecular orbital theory – bonding in homo and hetero nuclear diatomic molecules – energy level diagrams of N_2 , O_2 , NO and CO; π -molecular orbitals of butadiene and benzene; VSEPR theory and molecular shapes.

Unit II: Water Treatment

(9Periods)

Introduction, types of water, Impurities in water and their consequences. Hardness of water, units of hardness, disadvantages of hardness, measurement of hardness by EDTA method, numerical problems on measurement of hardness of water, boiler troubles-priming & foaming, scales & sludge, caustic embrittlement, boiler corrosion, softening of water– Ion exchange process, zeolite process, desalination of brackish water by reverse osmosis, Drinking water treatment- Ozonisation& chlorination, specifications of potable water as per WHO and BIS standards. Fluoride in ground water: Effects on human health, defluoridation method – Nalgonda method; merits and demerits of various defluoridation methods.

Unit III: Electrochemistry and Applications

(10 Periods)

Electrode potential, Nernst equation, reference electrodes (Calomel electrode and glass electrode), electrochemical cell, cell potential calculations. Primary cells – dry cell, alkali

metal sulphide batteries, Secondary cells – lead acid, lithium ion batteries, Fuel cells - Hydrogen-oxygen fuel cell, Methanol-oxygen fuel cell, Solid-oxide fuel cell.

Corrosion: Introduction, Definition, types of corrosion- wet (galvanic corrosion, concentration cell corrosion) and dry corrosion, Factors influencing corrosion, control of corrosion- sacrificial anodic protection, Impressed current cathodic protection, electroplating method (Nickel).

Unit IV: Instrumental Methods and Applications (9 Periods)

Introduction to spectroscopy–types of energy present in molecules, types of spectra, UV-Vis spectroscopy – principle, types of electronic transitions, chromophore, auxochrome, Bathochromic shift, Hypsochromic shift, Instrumentation of UV-Vis spectrophotometer, applications; Infrared spectroscopy – principle, types of vibrational modes, group frequencies, Instrumentation of IR spectrophotometer, applications. principle and applications of physicochemical methods (SEM, TEM, X-ray diffraction).

Unit V: Fuel chemistry and Lubricants (8 Periods)

Fuel chemistry: Types of fuels, calorific value, numerical problems based on calorific value; Liquid fuels, cracking of oils (Thermal and Fixed-bed catalytic cracking), knocking and anti-knock agents, Octane and Cetane values, Synthetic petrol: Fischer-Tropsch method and Bergius process.

Lubricants: Definition, functions of lubricants, mechanism of lubrication, classification of lubricants, properties of lubricants – viscosity and viscosity index, flash and fire points, cloud and pour points, Aniline points, neutralization number and mechanical strength.

Total Periods: 45

Topics for self-study are provided in the lesson plan

TEXT BOOKS:

1. P. C. Jain & Monika Jain, *Engineering Chemistry*, Dhanpat Rai Publishing Company (P) Ltd, New Delhi, 16th edition, 2013.
2. K.N. Jayaveera, G.V. Subba Reddy and C. Ramachandriah, *Engineering Chemistry*, McGraw Hill Publishers, New Delhi.

REFERENCE BOOKS:

1. J. D. Lee, *Concise Inorganic Chemistry*, Oxford University Press, 5th edition 2010.
2. Skoog and West, *Principles of Instrumental Analysis*, Thomson, 6th edition, 2007.
3. Peter Atkins, Julio de Paula and James Keelar, *Atkins' Physical Chemistry*, Oxford University Press, 10th edition, 2010.

I B. Tech. – I Semester

(19BT1HS01) COMMUNICATIVE ENGLISH

(Common to CE, ME, CSE, CSSE, IT and CSBS)

Int. Marks	Ext. Marks	Total Marks	L	T	P	C
40	60	100	3	-	-	3

PRE-REQUISITES: -

COURSE DESCRIPTION: Introduction to communication; Active listening; Effective speaking; Reading; Technical writing.

COURSE OUTCOMES: After successful completion of the course, students will be able to:

CO1. Demonstrate knowledge of English language, examining and applying the aspects of Process of communication, Paralinguistic features, Skimming, Scanning, and Elements of style in writing.

CO2. Analyze the modes and techniques of listening, speaking, reading, writing and apply appropriately to communicate effectively with the engineering community and society.

CO3. Apply reading and writing techniques in preparing documents by examining SQ3R Technique, Writer's Block, and Précis Writing.

CO4. Communicate effectively applying appropriate speaking techniques by examining and applying the communication styles in Conferences, Symposia, Seminars and Persuasive Speaking.

DETAILED SYLLABUS:

UNIT I - INTRODUCTION TO COMMUNICATION

(9 periods)

Introduction – Language as a Tool of Communication – Communicative Skills (Listening, Speaking, Reading and Writing) – Effective Communication – Modes of Communication– Barriers to Communication (classification) - Case study.

UNIT II - ACTIVE LISTENING

(9 periods)

Introduction – Traits of a Good Listener – Listening Modes – Types of Listening – Barriers to Effective Listening – Listening for General Content and Specific Information - Case study.

UNIT III - EFFECTIVE SPEAKING

(9 periods)

Introduction – Achieving Confidence, Clarity and Fluency – Paralinguistic Features – Barriers to Speaking – Types of Speaking – Conferences; significance, planning and preparation and procedure – Symposia and Seminars - Persuasive Speaking - Case study.

UNIT IV - READING

(9 periods)

Introduction – Reading and Interpretation – Intensive and Extensive Reading – Critical Reading --Techniques for Good Comprehension- SQ3R Reading Technique –Study Skills - Case study.

UNIT V – TECHNICAL WRITING

(9 periods)

Introduction – Language – Elements of Style – Techniques for Good Technical Writing – Paragraphs Construction – Essays: types, Steps to Essay Writing and Checklist – Précis Writing - Case study.

Total Periods: 45

Topics for self-study are provided in the lesson plan

TEXT BOOKS:

1. Meenakshi Raman & Sangeetha Sharma, *Technical Communication*, Oxford University Press, New Delhi, 2012.
2. Ashraf Rizvi, *Effective Technical Communication*, McGraw-Hill Education (India) Pvt. Ltd., New Delhi, 2018.

REFERENCE BOOKS:

1. Sanjay Kumar & Pushp Lata, *Communication Skills*, Oxford University Press, New Delhi, 2013.
2. Rajendra Pal and J. S. Korlahalli, *Essentials of Business Communication*, Sultan Chand and Son, New Delhi, 2010.

ADDITIONAL LEARNING RESOURCES

1. <https://www.skillsyouneed.com/ips/active-listening.html>: A useful summary of what active listening skills are.
2. https://en.wikipedia.org/wiki/Active_listening: Wikipedia entry about active listening.
3. <https://www.forbes.com/sites/womensmedia/2012/11/09/10-steps-to-effective-listening/#4b27a2503891>: Ten steps to Active Listening (by Forbes magazine).
4. <https://goo.gl/t1Uqrt>: 20 tips for organizing a conference.
5. <https://goo.gl/kPMr9u>: 10 important issues for speakers at a conference.
6. <https://goo.gl/C5bDvv>: Wikihow guide to organizing a conference.

I B. Tech. – I Semester

(19BT10501) PROGRAMMING FOR PROBLEM SOLVING

(Common to CE, ME, CSE, CSSE, IT, CSE (AI) and CSE (DS))

Int. Marks	Ext. Marks	Total Marks	L	T	P	C
40	60	100	3	1	-	4

PRE-REQUISITES: A course on Basic Mathematics

COURSE DESCRIPTION: Introduction to problem solving approach, Introduction to Python programming, control structures, sequences, sets, Dictionaries, Implementation of Data structures using Python, Modular programming, file handling, Data representation and Visualization.

COURSE OUTCOMES: After successful completion of the course, students will be able to:

CO1. Demonstrate knowledge on Python constructs to solve basic problems.

CO2. Develop and use Python modules to provide solutions to problems.

DETAILED SYLLABUS:

UNIT-I: INTRODUCTION TO PROBLEM SOLVING AND PYTHON PROGRAMMING

(10 Periods)

Problem Solving Aspect: top-down design, implementation of algorithms, building blocks of flow charts, program verification and efficiency of algorithms.

Python Programming: tokens, literals, identifiers, keywords, special symbols and operators; fundamental data types, expressions, type conversions, handling Input and output in Python.

UNIT-II: CONTROL STRUCTURES

(8 Periods)

Selection Statements: if statement, if-else statement, if-elif-else statement, nested-if statement.

Iterative Statements: while loop, for loop, break statement, continue statement, pass and else statements used with loops.

UNIT-III: SEQUENCES, SETS, DICTIONARIES AND DATA STRUCTURES

(9 Periods)

Sequences: Lists and operations - creating, inserting elements, updating elements, deleting elements, searching and sorting, list comprehensions, nested lists; **tuples** - creating, searching and sorting, nested tuples; **strings** - Initializing a string and string operations, string handling methods, string formatting; **sets** - set creation and operations; **dictionaries** - operations on dictionaries, dictionary methods, sorting elements using lambdas.

Data structures: Stacks - push, pop, peek and display operations on stack, applications of stack; **Queues** – enqueue, dequeue and display operations on queue, applications of queues.

UNIT-IV: MODULAR PROGRAMMING AND FILE HANDLING (10 Periods)

Modular Programming: need for functions, function definition, function call, variable scope and lifetime, return statement, positional arguments, keyword arguments, default arguments and variable-length arguments, recursive functions; Modules - math, NumPy, date and time.

File Handling: types of files, opening and closing files, reading and writing data.

UNIT-V: DATA REPRESENTATION AND VISUALIZATION (8 Periods)

Pandas: creating data frame, reading data from CSV files, indexing and selecting data, dealing with rows and columns; Visualization - bar plots, histogram, Scatter Plot.

Total Periods: 45

Topics for self-study are provided in the lesson plan

TEXT BOOKS:

1. R. Nageswara Rao, *Core Python Programming*, 2nd edition, Dreamtech Press, 2018.
2. R. G. Dromey, *How to solve it by Computer*, Pearson, 2006.

REFERENCE BOOKS:

1. Reema Thareja, *Python Programming using Problem Solving Approach*, 1st edition, Oxford University Press, 2017.
2. Charles Dierbach, *Introduction to Computer Science using Python: A Computational Problem-Solving Focus*, Wiley India, 2016.

I B.Tech. - I Semester

(19BT1BS32) ENGINEERING CHEMISTRY LAB

(Common to CE, ME, CSE, CSSE and IT)

Int. Marks	Ext. Marks	Total Marks	L	T	P	C
50	50	100	-	-	2	1

PRE-REQUISITES: -

COURSE DESCRIPTION: Estimation of hardness, alkalinity, dissolved oxygen of water samples, Iron, Strength of an acid in Pb-acid battery and residual chlorine in drinking water by volumetric methods; Measurement of viscosity of lubricants; Instrumental methods like conductivity meter, potentiometer, P^H meter and colorimeter; Characterization of simple organic compounds by UV-Vis and IR spectroscopy.

COURSE OUTCOMES: After successful completion of the course, students will be able to:

CO1. Apply analytical skills for the quantitative estimation of materials through volumetric methods of analysis and address the societal, health issues related to quality of water.

CO2. Develop analytical skills for the quantitative estimation of materials through instrumental methods of analysis.

CO3. Work independently and in teams to solve problems with effective communication.

A minimum of any **Ten** experiments are to be conducted among the following:

List of Experiments

1. Estimation of Hardness of water by EDTA method
2. Determination of alkalinity of Water sample
3. Estimation of Dissolved Oxygen in water by Winkler's method.
4. Estimation Fe (II) by Dichrometry
5. Conductometric titration of strong acid Vs strong base
6. Estimation of Ferrous ion by Potentiometry
7. Determination of strength of acid by P^H metric method
8. Determination of Strength of an acid in Pb-Acid battery
9. Determination of Viscosity by Ostwald's viscometer
10. Determination of percentage of Iron in Cement sample by colorimetry
11. Estimation of residual chlorine in drinking water.
12. Identification of simple organic compounds by UV-Vis and IR spectroscopy

TEXT BOOKS:

1. K. Mukkanti, *Practical Engineering Chemistry*, BS Publications, 2013.
2. K.N. Jayaveera, K.B. Chandra Sekhar, *Chemistry laboratory manual*, S.M. Enterprises Limited, 2013.

I B. Tech.-I Semester

(19BT1HS31) COMMUNICATIVE ENGLISH LAB

(Common to CE, ME, CSE, CSSE, IT and CSBS)

Int. Marks	Ext. Marks	Total Marks	L	T	P	C
50	50	100	-	-	2	1

PRE-REQUISITES: -

COURSE DESCRIPTION: Phonetics; Vocabulary Building; Grammar; Just a Minute; Elocution/Impromptu; Giving Directions; Role Plays; Public Speaking; Describing Objects; Reading Comprehension; Listening Comprehension; Information Transfer; Letter Writing

COURSE OUTCOMES: After successful completion of the course, students will be able to:

CO1. Demonstrate knowledge of Phonetics by examining and applying sounds of English in Phonetic Transcription.

CO2. Analyze sentence structures by applying and demonstrating the skills of Vocabulary and Grammar.

CO3. Apply appropriate listening and reading skills by analyzing the context and demonstrate in Listening Comprehension and Reading Comprehension.

CO4. Function effectively as an individual and as a member in diverse teams examining and applying speaking skills in Just A Minute and Role Play.

CO5. Communicate effectively applying appropriate writing and speaking techniques by examining and demonstrating knowledge through Describing Objects, Information Transfer and Letter Writing.

***First ten exercises are mandatory among the following:**

List of Exercises:

1. Just a Minute, Elocution/Impromptu

Steps to be followed – Useful tips – Dos & Don'ts – Preparation – Examples

2. Phonetics

Sounds of English – Consonants – Vowels – Speech Organs – Phonetic Transcription – Word Accent – Basics of Intonation

3. Vocabulary Building

Prefixes & Suffixes – Synonyms & Antonyms – Phrasal verbs – Idioms – One word substitutes – Words often confused

4. Grammar

Tenses – Nouns – Word order and error correction

5. Giving Directions

Useful phrases – Sample conversations – Exercises

6. Role Plays

Useful tips – Dos & Don'ts – Exercises – Role Plays for practice

7. Public Speaking

Stage presence – Voice control – Body Language – Rehearsals – Audience – Delivery – Dos & Don'ts – Project Submission

8. Letter Writing

Introduction – Objective – Formats – Types – Exercises

9. Describing Objects

Jargon – Useful Phrases – Do's & Don'ts – Exercises

10. Listening Comprehension

Introduction – Types of listening – Practice – Benefits of listening – Exercises

11. Information Transfer

Tables – Pie Charts – Venn Diagrams – Graphs – Flow Charts – Steps to be followed – Exercises

12. Reading Comprehension

Introduction – Types of reading – Inferring – Critical analysis – Exercises

TEXT BOOK:

1. Communicative English Lab Manual (SVEC-19)

REFERENCE BOOKS:

1. D. Sudha Rani, *A Manual for English Language Laboratories*, Pearson, Noida, 2010.
2. Nira Kumar, *English Language Laboratories*, PHI Learning Pvt. Ltd., New Delhi, 2011.

SUGGESTED SOFTWARE:

1. SoftX
2. Speech Solutions
3. English Pronunciation Dictionary by Daniel Jones
4. Learning to Speak English 8.1, The Learning Company – 4 CDs.
5. Mastering English: Grammar, Punctuation and Composition.
6. English in Mind, Herbert Puchta and Jeff Stranks with Meredith Levy, Cambridge.
7. Dorling Kindersley Series of Grammar.
8. Language in Use 1, 2 & 3
9. Cambridge Advanced Learner's Dictionary - 3rd Edition
10. Centronix – Phonetics
11. Let's Talk English, Regional Institute of English South India.

ADDITIONAL LEARNING RESOURCES

1. <https://goo.gl/IjE45p>: Amazon India site – with thousands of different product descriptions
2. <https://goo.gl/3ozeO6>: 15 ways to calm your nerves before giving a presentation.
3. <https://goo.gl/p20ttk>: useful site for more language about introducing yourself.

I B. Tech. – I Semester

(19BT10331) COMPUTER AIDED ENGINEERING DRAWING

(Common to CE, ME, CSE, CSSE and IT)

Int. Marks	Ext. Marks	Total Marks	L	T	P	C
50	50	100	-	1	2	2

PRE-REQUISITES: --

COURSE DESCRIPTION: Engineering drawing conventions; Importance of engineering drawing; fundamental concepts of sketching; computer aided drafting and different types of projections of geometric entities (both 2D and 3D) through computer aided drafting packages.

COURSE OUTCOMES: After successful completion of the course, students will be able to:

CO1: Apply the principles of engineering drawing, Methods and CAD tools to draw the Geometries, Curves and Orthographic projections used to communicate in engineering applications.

CO2: Develop lateral surfaces of solids and draw Isometric views of given objects for engineering communication using principles of engineering drawing and CAD tools.

CO3: Work independently / in groups & communicate effectively in oral and written forms.

DETAILED SYLLABUS:

Introduction to Engineering Graphics and Design:

Principles, significance -Conventions in drawing-lettering - BIS conventions-Dimensioning principles and conventional representations.

Exercises:

1. Practice exercise on Basic Lettering and Dimensioning
2. Practice exercise on Conventional representations

Introduction to AutoCAD: Basic drawing and editing commands: line, circle, rectangle, erase, view, undo, redo, snap, object editing, moving, copying, rotating, scaling, mirroring, layers, templates, polylines, trimming, extending, stretching, fillets, arrays, dimensions.

Exercises:

3. Practice exercise using basic drawing commands
4. Practice exercise using editing commands

CONICS, CURVES, PROJECTION OF POINTS, LINES AND PLANES

Conics & Special Curves: Conic sections including the rectangular hyperbola-eccentricity method only; Cycloid, Epicycloid and Hypocycloid, Involutives.

Exercises:

5. Practice exercises on Ellipse, Parabola, Hyperbola and Rectangular Hyperbola
6. Practice exercises on Cycloid, Epicycloid, Hypocycloid and Involutives

Projection of points, lines and planes: Projection of points in any quadrant, lines inclined to one or both planes, finding true lengths, angle made by line, Projections of regular plane surfaces.

Exercises:

7. Practice exercises on Projection of points
8. Practice exercises on projection of lines inclined to one plane
9. Practice exercises on projection of lines inclined to both planes
10. Practice exercises on Projections of regular plane surfaces

PROJECTION OF SOLIDS AND SECTION OF SOLIDS

Projection of solids: Projection of regular solids inclined to one plane.

Sections of solids: Section planes and sectional view of right regular solids- prism, cylinder, pyramid and cone, True shapes of the sections.

Exercises:

11. Practice exercises on Projections of regular solids
12. Practice exercises on Sections of solids

DEVELOPMENT OF SURFACES

Development of surfaces: Development of surfaces of right regular solids-prism, cylinder, pyramid, cone and their sectional parts.

Exercises:

13. Practice exercises on Development of surfaces of right regular solids

ORTHOGRAPHIC AND ISOMETRIC PROJECTIONS

Orthographic Projections: Systems of projections, conventions and application to orthographic projections.

Isometric Projections: Principles of isometric projection- Isometric scale; Isometric views: lines, planes, simple solids.

Exercises:

14. Practice exercises on Orthographic Projections
15. Practice exercises on Isometric Projections

TEXT BOOKS:

1. D.M.Kulkarni, A.P.Rastogi, A.K.Sarkar, *Engineering Graphics with AutoCAD*, PHI Learning Private Limited, New Delhi, Revised edition, 2010.
2. N. D. Bhatt and V. M. Panchal, *Engineering Drawing*, Charotar Publishing House, Gujarat, 51st edition, 2013.

REFERENCE BOOKS/LABORATORY MANUALS:

1. Sham Tickoo, *AutoCAD 2013 for Engineers and Designers*, Dreamtech Press, 2013.
2. M.H.Annaiah&Rajashekar Patil, *Computer Aided Engineering Drawing*, New Age International Publishers, 4th edition, 2012.

I B. Tech. – I Semester

(19BT10531) PROGRAMMING FOR PROBLEM SOLVING LAB

(Common to CE, ME, CSE, CSSE, IT, CSE (AI) and CSE (DS))

Int. Marks	Ext. Marks	Total Marks	L	T	P	C
50	50	100	-	-	2	1

PRE-REQUISITES: A course on Basic Mathematics

COURSE DESCRIPTION: The course is designed to provide hands on practice on Scratch programming and python programming for problem solving.

COURSE OUTCOMES: After successful completion of the course, students will be able to:

CO1. Develop scripts using Scratch tool to simulate simple problems.

CO2. Apply Python Constructs and Modules to develop solutions for real-life problems.

CO3. Function effectively as an individual and in team to foster knowledge and creativity.

CO4. Write and present a substantial technical report/ document effectively.

PRACTICAL EXERCISES:

- Design a script in Scratch to simulate Airplane for take-off and land.
 - Design a script in Scratch to make a sprite to ask the user to enter two different numbers and an arithmetic operator and then calculate and display the result.
- Design a script in Scratch to calculate factorial of a given number.
 - Design a script in Scratch to simulate Maze game. (Hint: To get Maze images refer <http://inventwithScratch.com/downloads/>)
- Write a python script to read two integer numbers and perform arithmetic operations.
 - Write a python script to evaluate following expressions by considering necessary inputs.
i) $ax^2 + bx + c$ ii) $ax^5 + bx^3 + c$ iii) $(ax + b) / (ax - b)$ iv) $x - a / b + c$
- Write a python script to convert given decimal number into octal, hexa decimal and binary.
 - Write a python script to read four integer values separated with commas and display the sum of those four numbers.
 - Write a python script to print "SVEC" with prefix of ten spaces by using `format()`.
- Write a python script to calculate electricity bill based on following slab rates.

<u>Consumption units</u>	<u>Rate (in Rupees/Unit)</u>
0-100	4
101-150	4.6
151-200	5.2
201-300	6.3
Above 300	8

(Hint: To get Consumption units take current Meter reading, old meter reading from the user as input)

b) Print the following pattern using python script.

```

                1
              1 2 1
            1 2 3 2 1
          1 2 3 4 3 2 1
        1 2 3 4 5 4 3 2 1
```

- 6) a) Write a python script to read N student details like name, roll number, branch and age. Sort the student details based on their names and display.
b) Write a python script to delete duplicate strings from a list of strings. (Insertion order should maintain after deleting duplicate string).
c) Write a python script to read N number of student details into nested list and convert that as a nested dictionary.
- 7) a) Design a function that can perform sum of two or three or four numbers.
b) Write a python script to implement towers of Hanoi problem.
c) Write a Python function `primesquare(l)` that takes a nonempty list of integers and returns True if the elements of l alternate between perfect squares and prime numbers, and returns False otherwise. Note that the alternating sequence of squares and primes may begin with a square or with a prime. Here are some examples to show how your function should work.
- ```
>>>primesquare([4])
True
>>>primesquare([4,5,16,101,64])
True
>>>primesquare([5,16,101,36,27])
False
```
- 8) a) Write a python script to perform arithmetic operations on numpyarrays.  
b) Write a python script to perform following matrix operations using numpy.  
i) Dot product ii) Matrix product iii) Determinant iv) Inverse
- 9) a) Write a python script to Create Pandas dataframe using list of lists.  
b) Write a python script to load data from a CSV file into a Pandas DataFrame and perform basic operations on it.
- 10) a) Draw a Scatter Plot by considering an appropriate data set.  
b) Draw histograms by considering an appropriate data set.
- 11) Mini Project-1  
12) Mini Project-2

#### TEXT BOOK:

1. R. Nageswara Rao, *Core Python Programming*, 2<sup>nd</sup> edition, Dreamtech Press, 2018.



## I B. Tech. - II semester

### (19BT2BS01) TRANSFORMATION TECHNIQUES AND LINEAR ALGEBRA

(Common to CE, ME, EEE, ECE, EIE, CSE, CSSE, IT, CSE (AI) and CSE (DS))

| Int. Marks | Ext. Marks | Total Marks | L | T | P | C |
|------------|------------|-------------|---|---|---|---|
| 40         | 60         | 100         | 3 | 1 | - | 4 |

#### PRE-REQUISITES: -

**COURSE DESCRIPTION:** Fourier Series and Fourier Transforms; Laplace Transforms; Inverse Laplace Transforms; Linear Algebra-I (Matrices); Linear Algebra-II (Vector Spaces).

**COURSE OUTCOMES:** After successful completion of the course, students will be able to:

**CO1:** Apply the knowledge of Fourier and Laplace transform techniques to solve differential equations.

**CO2:** Analyze linear transformations and associated matrices to solve engineering problems by applying the knowledge of linear algebra.

#### DETAILED SYLLABUS:

##### UNIT- I: Fourier Series and Fourier Transforms (9 Periods)

Fourier series: Determination of Fourier coefficients, Euler's formulae, convergence of Fourier series (Dirichlet's conditions), Fourier series in  $(0, 2l)$ ,  $(-l, l)$ ; Fourier series of even and odd functions; Half-range Fourier sine and cosine expansions in  $(0, l)$ ; Fourier integral theorem (statement only), Fourier sine and cosine integrals; Fourier transforms, Fourier sine and cosine transforms, Inverse Fourier transforms.

##### UNIT-II: Laplace Transforms (9 Periods)

Definition of Laplace transform, existence conditions, Laplace transform of standard functions, Properties of Laplace transforms, Laplace transforms of derivatives, Laplace transforms of integrals, multiplication by  $t^n$ , division by  $t$ , Laplace transform of periodic functions, Laplace transforms of unit step function and unit impulse function.

##### UNIT- III: Inverse Laplace Transforms (9 Periods)

Inverse Laplace transform by different methods; Convolution theorem (without proof), inverse Laplace transforms by convolution theorem; Applications of Laplace transforms to ordinary differential equations of first and second order with constant coefficients.

##### UNIT- IV: Linear Algebra-I (Matrices) (9 Periods)

Rank of a matrix: echelon form; Linear systems of equations: solving system of Homogeneous and Non-Homogeneous equations; Eigen values and Eigen vectors of a matrix and properties (without proofs), Diagonalization of a matrix by orthogonal transformation; Quadratic forms and nature of the quadratic forms, reduction of quadratic form to canonical form by orthogonal transformation.

**UNIT- V: Linear Algebra-II (Vector Spaces)****(9 Periods)**

Vector spaces, Linear dependence and independence of vectors, basis, dimension, Linear transformations (maps), range and kernel of a linear map, rank and nullity, inverse of a linear transformation, rank-nullity theorem (without proof), matrix associated with a linear map.

**Total Periods: 45*****Topics for self-study are provided in the lesson plan*****TEXT BOOKS:**

1. T.K.V. Iyengar, B. Krishna Gandhi, S. Ranganatham and M.V.S.S.N. Prasad, *Engineering Mathematics-II*, S. Chand & Company, 10<sup>th</sup> edition, 2016.
2. B. S. Grewal, *Higher Engineering Mathematics*, Khanna publishers, 44<sup>th</sup> edition, 2017.
3. David Poole, *Linear Algebra: A Modern Introduction*, Brooks/Cole, 2<sup>nd</sup> edition, 2005.

**REFERENCE BOOKS:**

1. B.V. Ramana, *Higher Engineering Mathematics*, Tata McGraw hill, 1<sup>st</sup> edition, 2017.
2. V.Krishna Murthy, Mainra and Arora: *An Introduction to Linear Algebra*, Affiliated East-West Press, 1993.

## I B. Tech. - II Semester

### (19BT1BS02) BIOLOGY FOR ENGINEERS

(Common to CE, ME, CSE, CSSE, IT and CSBS)

| Int. Marks | Ext. Marks | Total Marks | L | T | P | C |
|------------|------------|-------------|---|---|---|---|
| 40         | 60         | 100         | 2 | - | - | 2 |

#### PRE-REQUISITES: --

**COURSE DESCRIPTION:** Living Organisms; Proteins, Nucleic acids and Enzymes; Genetics and Molecular Biology; Recombinant DNA technology; Human Physiology and Applied Biology.

**COURSE OUTCOMES:** After successful completion of the course, students will be able to:

CO1. Apply the basic knowledge of biology to understand the significance of various biological techniques.

CO2. Identify the role of DNA in the molecular basis of information transfer and understand single gene disorders related to the health perspective.

CO3. Apply the basic knowledge of bio-analytical devices and methods to assess health issues.

#### DETAILED SYLLABUS:

##### UNIT I – Living Organisms

(6 Periods)

Comparison of biological organisms with man-made systems, Classification of living organisms, Cellular basis of life, differences between prokaryotes and eukaryotes, classification on the basis of carbon and energy sources, molecular taxonomy

##### UNIT II – Proteins, Nucleic acids and Enzymes

(6 Periods)

Biomolecules, structure and functions of proteins and nucleic acids, Industrial applications of enzymes, Fermentation and its industrial applications

##### UNIT III – Genetics and Molecular Biology

(6 Periods)

Mendel's laws, single gene disorders in humans, Genetic code, DNA replication, Transcription, Translation.

##### UNIT IV – Recombinant DNA technology

(6 Periods)

Recombinant DNA Technology: recombinant vaccines, transgenic microbes, plants and animals, animal cloning, biosensors, biochips.

##### UNIT V – Human Physiology and Applied Biology

(6 Periods)

Fundamentals of Human physiology, neurons, synaptic and neuromuscular junctions, Introduction to EEG, DNA fingerprinting, DNA Micro array and Genomics.

**Total Periods: 30**

**Topics for self-study are provided in the lesson plan**

**TEXT BOOKS:**

1. Rajiv Singal, Gaurav Agarwal, *Biology for Engineers*, CBS, 2019.
2. S. Sing and T. Allen, *Biology for Engineers*, Vayu Education of India, 2014.

**REFERENCE BOOKS:**

1. B. Alberts, A. Johnson et al., *The molecular biology of the cell*, Garland Science, 6<sup>th</sup> edition, 2014.
2. A. T. Johnson, *Biology for Engineers*, CRC press, 2011.

**ADDITIONAL LEARNING RESOURCES:**

1. Structure and function of Proteins: <https://nptel.ac.in/courses/104102016/16>
2. Enzyme catalysis: <https://nptel.ac.in/courses/103103026/module3/lec35/4.html>
3. Biochips: <https://nptel.ac.in/courses/112104029/3>

## I B. Tech. - II Semester

### (19BT1BS03) ENGINEERING PHYSICS

(Common to CSE, CSSE and IT)

| Int. Marks | Ext. Marks | Total Marks | L | T | P | C |
|------------|------------|-------------|---|---|---|---|
| 40         | 60         | 100         | 3 | - | - | 3 |

#### PRE-REQUISITES: -

**COURSE DESCRIPTION:** Wave Optics; Electromagnetic Waves; Fiber Optics; Semiconductors; Dielectrics; Magnetism; Superconductors and Nanomaterials

**COURSE OUTCOMES:** After successful completion of the course, students will be able to:

CO1. Apply the knowledge of light waves to interpret the concepts of Interference, Diffraction and Polarization.

CO2. Demonstrate the concepts of electromagnetic wave propagation in an Optical fibers.

CO3. Apply the basic knowledge of semiconductors to understand the functioning of various optoelectronic devices.

CO4. Demonstrate the basic knowledge of dielectric and magnetic properties to understand the various dielectric polarizations and magnetic materials.

CO5. Understand the concepts of superconductors and nanomaterials to familiarize their applications in relevant fields.

#### DETAILED SYLLABUS:

##### UNIT-I: WAVE OPTICS

(09 Periods)

Interference: Principle of superposition - Interference of light - Theory of interference fringes - Conditions for sustained interference - Interference in thin films (reflected light) - Newton's rings - Determination of wavelength.

Diffraction: Fraunhofer diffraction - Single slit diffraction - Diffraction grating - Grating spectrum - Determination of wavelength.

Polarization: Polarization by reflection, refraction and double refraction - Nicol's prism - Half wave and Quarter wave plate - Engineering applications of interference, diffraction and polarization.

##### UNIT-II: ELECTROMAGNETIC WAVES AND FIBER OPTICS

(10 Periods)

Divergence, Curl of Electric and Magnetic Fields - Maxwell's Equations (qualitative)- Electromagnetic wave propagation (conducting and non conducting media).

Introduction to fiber optics - Total Internal Reflection - Critical angle of propagation - Acceptance angle, Acceptance cone - Numerical Aperture - Classification of fibers based on Refractive index profile, modes - Attenuation losses - Dispersion - Propagation of electromagnetic wave through optical fiber - Block diagram of fiber optic communication - Applications of an optical fiber - Fiber optic Sensors (temperature, displacement).

##### UNIT-III: SEMICONDUCTORS

(10 Periods)

Origin of energy bands - Classification of solids based on energy bands - Intrinsic semiconductors - Density of electrons in intrinsic semiconductor - Density of holes in

intrinsic semiconductor (qualitative) - Intrinsic carrier concentration - Fermi energy - Electrical conductivity of intrinsic semiconductors - Extrinsic semiconductors - Density of charge carriers in n-type - Density of charge carriers in p-type (qualitative) - Direct and Indirect band gap semiconductors - Hall effect, Hall coefficient - Applications of Hall effect - Drift and Diffusion currents -pn junction - Semiconducting materials for optoelectronic devices : Photodiode and Semiconductor diode laser.

#### **UNIT-IV: DIELECTRICS AND MAGNETISM**

**(09 Periods)**

Introduction to dielectrics - Electric polarization - Dielectric polarizability, susceptibility and dielectric constant - Types of polarizations (qualitative) - Frequency dependence of polarization - Lorentz (internal) field - Dielectric break down - Piezoelectricity - Applications of dielectrics.

Introduction to magnetics - Magnetic dipole moment, magnetization, magnetic susceptibility and permeability - Origin of magnetic moment - Classification of magnetic materials - Hysteresis loop - Soft and hard magnetic materials.

#### **UNIT-V: SUPERCONDUCTORS AND NANOMATERIALS**

**(07 Periods)**

Introduction to Superconductors, Properties - Critical parameters of Superconductors - Meissner effect - Penetration depth - Types of Superconductors - BCS Theory - Josephson effect (AC & DC) - High  $T_c$  Superconductors - Applications.

Basic principles of nanomaterials - Synthesis of nanomaterials by PLD method - Properties of nanomaterials(Electrical, Magnetic, Optical and Mechanical) - Applications of nanomaterials.

**Total Periods: 45**

***Topics for self-study are provided in the lesson plan***

#### **TEXT BOOKS:**

1. M.N. Avadhanulu, P.G.Kshirsagar& T.V.S Arun Murthy, *A Text book of Engineering Physics*, S. Chand Publications, 11<sup>th</sup> edition, 2019.
2. P. K. Palaniswamy, *Engineering Physics*, Scitech Publications India Private Limited, 2<sup>nd</sup>edition, 2009.

#### **REFERENCE BOOKS:**

1. K. Thyagarajan, *Engineering Physics*, McGraw-Hill Education (India) Pvt. Ltd, 2016.
2. R.K. Gaur and S.L. Gupta, *Engineering Physics*, Dhanpat Rai Publications (P) Ltd, 2015.

## I B. Tech. – II Semester

### (19BT10201) BASIC ELECTRICAL AND ELECTRONICS ENGINEERING

(Common to CE, ME, CSE, CSSE and IT)

| Int. Marks | Ext. Marks | Total Marks | L | T | P | C |
|------------|------------|-------------|---|---|---|---|
| 40         | 60         | 100         | 3 | - | - | 3 |

**PRE-REQUISITES:** --

**COURSE DESCRIPTION:** Principles of Electrical Systems; AC Machines; Semiconductor Devices and Op-Amps.

**COURSE OUTCOMES:** After successful completion of the course, students will be able to:

- CO1. Analyze electrical circuits by applying the conceptual knowledge of circuit elements.
- CO2. Demonstrate knowledge on various generation technologies, protection devices, safety procedures and BEE standards.
- CO3. Demonstrate knowledge on characteristics and applications of transformers and AC machines.
- CO4. Demonstrate knowledge on characteristics and applications of diode, BJT and Op-amps.

#### DETAILED SYLLABUS:

##### Unit-I: Principles of Electrical Systems-I

(9 Periods)

Basic electrical sources: DC-Battery, AC sources–Single loop generator; Single phase and three phase supply; Electrical circuit elements (R, L and C), Ohm's law, Kirchhoff's laws, Representation of sinusoidal waveforms, peak and RMS values, phasor representation, reactive power, apparent power, real power, energy and power factor.

##### Unit-II: Principles of Electrical Systems-II

(9 Periods)

Significance of Power factor and power factor correction, most economical power factor. Typical layout of electrical grid; Typical layout and operation of Hydro, Thermal and Solar Power Plants; Fuse, circuit breaker (MCB, MCCB, RCCB, ELCB), relay (elementary treatment); Inverter and UPS (block diagram approach only). Earthing – importance of earthing, pipe earthing and plate earthing; Safety measures. Energy Efficiency (Star rating) standards by BEE.

##### Unit-III: Transformers and AC Machines

(9 Periods)

Construction and working of a single phase transformer, EMF Equation; Construction and working of three phase induction motor, torque equation, torque-slip characteristics, applications; construction and working of a resistor start & capacitor start and run single phase induction motor, applications; Construction and working of synchronous machine, applications.

##### UNIT-IV: Semiconductor Devices

(10 Periods)

PN Junction diode, Characteristics, applications - half wave and full wave rectifier. Zener diode, characteristics, application-Regulator. BJT- operation, configurations, characteristics, applications - switch and amplifier

**UNIT-V: Op-Amps**

**(8 Periods)**

Operational Amplifier: Block diagram of Op-Amp, equivalent circuit, Op-Amp AC and DC Characteristics, Inverting and Non-Inverting modes. Applications - Adder, Comparator, Integrator and Differentiator.

**Total Periods: 45**

***Topics for self-study are provided in the lesson plan***

**TEXT BOOKS:**

1. Ashfaq Hussain, *Fundamentals of Electrical Engineering*, Dhanpatrai & Co. (P) Ltd., 3<sup>rd</sup> edition, New Delhi, 2009.
2. R. L. Boylestad and Louis Nashelsky, *Electronics Devices and Circuits*, PHI, 11<sup>th</sup> edition, 2009.

**REFERENCE BOOKS:**

1. M.S. Naidu, S. Kamakshaiah, *Introduction to Electrical Engineering*, Tata McGraw-Hill Education, New Delhi, 2007.
2. D. Roy Chowdhury, *Linear Integrated Circuits*, New Age International Pvt. Ltd., 4<sup>th</sup> edition, 2011.



## I B. Tech. – II Semester

### (19BT20501) DIGITAL LOGIC DESIGN

(Common to CSE, CSSE, IT, CSE (AI) and CSE (DS))

| Int. Marks | Ext. Marks | Total Marks | L | T | P | C |
|------------|------------|-------------|---|---|---|---|
| 40         | 60         | 100         | 3 | - | - | 3 |

**PRE-REQUISITES:** --

**COURSE DESCRIPTION:** Foundation in design and analysis of the operation of digital gates; Concepts of Boolean algebra, Minimization of logic circuits; Design and implementation of combinational and sequential logic circuits; Analysis and design of flip-flops, registers, and counters and comparison of their behavior and characteristics; Design digital systems using Programmable logic.

**COURSE OUTCOMES:** After successful completion of the course, students will be able to:

- CO1.** Apply knowledge of binary systems, logic gates and Boolean functions to minimize and implement digital circuits.
- CO2.** Develop digital systems using combinational and sequential logic to solve engineering problems.

#### DETAILED SYLLABUS:

##### **UNIT- I: BINARY SYSTEMS AND BOOLEAN ALGEBRA (10 periods)**

Introduction, Binary Numbers, Number Base Conversions, Error Detection and Correction, Complements of Numbers, Signed Binary Numbers, Binary Codes, Boolean Algebra, Boolean Functions, Canonical and Standard Forms, Digital Logic Gates.

##### **UNIT-II: GATE LEVEL MINIMIZATION (9 periods)**

The Map Method, Four Variable K-Map, Product-of-Sums and Sum-of-Products Simplification, Don't Care Conditions, NAND and NOR Implementations, Other Two Level Implementations, Exclusive-OR function.

##### **UNIT-III: COMBINATIONAL LOGIC (9 periods)**

Combinational Circuits, Analysis of Combinational Circuits, Design Procedure, Binary Adder-Subtractor, Decimal Adder, Binary Multiplier, Magnitude Comparator, Decoders, Encoders, Multiplexers, De-Multiplexers.

##### **UNIT-IV: SEQUENTIAL LOGIC (10 periods)**

Latches, Flip-Flops, Analysis of Clocked Sequential Circuits, Design of Synchronous Sequential Circuits, Registers, Shift Registers, Ripple Counters, Synchronous Counters, Ring Counter and Johnson Counter.

##### **UNIT-V: PROGRAMMABLE LOGIC (7 periods)**

**Programmable Memories** – RAM, ROM, Programmable Logic Array, Programmable Array Logic, Sequential Programmable Devices.

**Total Periods: 45**

*Topics for self-study are provided in the lesson plan*

**TEXT BOOK:**

1. M. Morris Mano, Michael D. Ciletti, *Digital Design: With an Introduction to the Verilog HDL, VHDL, and System Verilog*, 6<sup>th</sup> edition, Pearson, 2018.

**REFERENCE BOOKS:**

1. A. Anand Kumar, *Switching Theory and Logic Design*, 3<sup>rd</sup> edition, PHI Learning Private Limited, India, 2016.
2. Charles H. Roth, Jr. and Larry L. Kinney, *Fundamentals of Logic Design*, 7<sup>th</sup> edition, Cengage Learning, 2015.
3. Alan B. Marcovitz, *Introduction to Logic Design*, 3<sup>rd</sup> edition, McGraw Hill, 2010.

## I B. Tech. – II Semester

### (19BT21501) OBJECT ORIENTED PROGRAMMING THROUGH JAVA

(Common to CSE, CSSE, IT, CSE (AI) and CSE (DS))

| Int. Marks | Ext. Marks | Total Marks | L | T | P | C |
|------------|------------|-------------|---|---|---|---|
| 40         | 60         | 100         | 3 | - | - | 3 |

**PRE-REQUISITES:** A course on Programming for Problem Solving

**COURSE DESCRIPTION:** Introduction to Object Oriented Programming, Classes and Objects; Inheritance, Packages, Interfaces; Exception handling, Multithreading; Collection Classes; Applets, Swings, Event handling.

**COURSE OUTCOMES:** After successful completion of the course, students will be able to:

CO1. Demonstrate knowledge on object oriented programming constructs to solve programming problems.

CO2. Analyze object oriented programming features – polymorphism, inheritance, exception handling and multithreading for reusability.

CO3. Develop user interfaces using GUI programming techniques.

#### DETAILED SYLLABUS:

##### UNIT I : INTRODUCTION

(9 periods)

Introduction to Object Oriented Programming, Java Buzzwords, History, Java Environment, Java Components, Programming Paradigms, Naming Conventions.

**Classes and Objects:** Introduction to classes, objects, Constructors, Garbage Collection, this keyword, Access Control, Features of Object Oriented Programming.

##### UNIT II: DATA TYPES, CONTROL STATEMENTS, POLYMORPHISM (9 periods)

Data Types, Variables, Type Conversions (Boxing and Unboxing/Wrapping and Unwrapping) and Casting, Arrays, Operators, Decision Making Statements, Looping Statements, Methods, Recursion, Method Overloading, Constructor Overloading, Parameter Passing, String Class, Final Keyword.

**Utility Classes:** String Tokenizer, Scanner, Random, Bit Set.

##### UNIT III: INHERITANCE, PACKAGES, INTERFACES

(9 periods)

**INHERITANCE:** Introduction, Classification, Abstract Classes, Final keyword with Inheritance.

**PACKAGES:** Basics, Creating and Accessing a package, CLASSPATH, Importing packages.

**INTERFACES:** Definition, Implementing Interfaces, Extending Interfaces, Nested Interfaces, Applying Interfaces, Variables in Interfaces.

**UNIT IV: EXCEPTION HANDLING, MULTITHREADING, COLLECTION FRAMEWORK  
(9 periods)**

**EXCEPTION HANDLING:** Exception, Types of Exception, Keywords: try, catch, throw, throws and finally, Built-in Exceptions, User Defined Exceptions.

**MULTITHREADING:** Process, Thread, Thread Model, Creating a thread, Priorities, Thread Synchronization, Inter-thread Communication.

**COLLECTION FRAMEWORK:** FrameworkHierarchy, ArrayList, LinkedList, HashSet.

**UNIT V – APPLETS, SWINGS, EVENT HANDLING (9 periods)**

**APPLET CLASS:** Basics, Types, Architecture, Skeleton, Parameter passing to applets.

**SWINGS:** Introduction, Features, Hierarchy, Swing GUI Components, Packages in Swings, Swing Control Classes and Methods.

**EVENT HANDLING:** Event Classes, Event Listener Interfaces - Mouse and Key, Adapter Classes.

**Total Periods: 45**

***Topics for self-study are provided in the lesson plan***

**TEXT BOOKS:**

1. Herbert Schildt, *Java the Complete Reference*, Ninth Edition, Oracle Press, 2014.

**REFERENCE BOOKS:**

1. Sachin Malhotra and Saurab Choudhary, *Programming in Java*, Second Edition, OxfordUniversity press, 2014.
2. Y. Daniel Liang, *Introduction to Java Programming*, Pearson Education.
3. T. Budd, *Understanding Object-Oriented Programming with Java*, Pearson Education.

**ADDITIONAL LEARNING RESOURCES**

- <https://docs.oracle.com/javase/tutorial/index.html>

## I B. Tech. - II Semester

### (19BT1BS31) ENGINEERING PHYSICS LAB

(Common to CSE, CSSE and IT)

| Int. Marks | Ext. Marks | Total Marks | L | T | P | C |
|------------|------------|-------------|---|---|---|---|
| 50         | 50         | 100         | - | - | 2 | 1 |

**PRE-REQUISITES:** --

**COURSE DESCRIPTION:** Determination of wavelength of light and thickness of a thin film; numerical aperture and acceptance angle of optical fiber; Characteristics of various semiconductor diodes; Resistivity of semiconductor; magnetic field along axial line of a current carrying coil

**COURSE OUTCOMES:** After successful completion of the course, students will be able to:

**CO1.** Apply the basic knowledge of light waves and semiconductors to demonstrate the functioning of optoelectronic devices.

**CO2.** Understand the experimental procedures to calculate the thickness of a thin film, Hall coefficient, Hysteresis losses, and acceptance angle of an optical fiber.

**CO3.** Determine the experimental values of magnetic field induction, wave length of a light source, energy gap of a semiconductor.

**CO4:** Apply skills to plot characteristic curves to determine the various parameters of semiconductor diodes.

**CO5.** Work independently and in teams to solve problems with effective communication.

A minimum of any **Ten** experiments are to be conducted among the following:

#### List of Engineering Physics Experiments:

1. Determine the thickness of the wire using wedge shape method.
2. Determination of wavelength of light source by Newton's ring method.
3. Determination of wavelength by plane diffraction grating method.
4. Estimation of magnetic field along the axis of a circular coil carrying current.
5. Study the variation of Magnetic field induction (B) vs Magnetic field strength (H) by magnetizing the magnetic material (B-H Curve).
6. Determination the numerical aperture of a given optical fibre and hence to estimate its acceptance angle.
7. Determination of number of charge carriers and Hall coefficients of a given semiconductor using Hall Effect.
8. Determine the resistivity of semiconductor by four probe method.
9. Determine the energy gap of a semiconductor.
10. Study the I-V characteristics of pn junction diode.
11. Estimation of threshold voltages of different LED's.
12. Study the characteristics of Photodiode.
13. Determination of wavelength of laser by using diffraction grating.

#### REFERENCE BOOKS:

1. S. Balasubramaniam and M.N. Srinivasan, *A Text book of practical physics*, S Chand Publications, 2017.
2. <http://vlab.amrita.edu/index.php> - Virtual Labs, Amrita University.

## I B. Tech. – II Semester

### (19BT10231) BASIC ELECTRICAL AND ELECTRONICS ENGINEERING LAB

(Common to CE, ME, CSE, CSSE and IT)

| Int. Marks | Ext. Marks | Total Marks | L | T | P | C |
|------------|------------|-------------|---|---|---|---|
| 50         | 50         | 100         | - | - | 2 | 1 |

**PRE-REQUISITES:** Physics at intermediate level.

**COURSE DESCRIPTION:** Practical investigations on Electrical circuits, AC Machines, Semiconductor Devices and Op-Amps.

**COURSE OUTCOMES:** After successful completion of the course, student will be able to:

- CO1.** Analyze, measure, interpret and validate the practical observations by applying the fundamental knowledge of electrical circuits, machines and electronic devices.
- CO2.** Design Op-amp based amplifier, voltage summer and integrator circuits for desired specifications.
- CO3.** Work independently and in teams to solve problems with effective communication.

#### List of Experiments:

Minimum Ten experiments are to be conducted.

1. Measurement of electrical quantities (AC & DC) using Voltmeter, Ammeter and Wattmeter.
2. Verification of Ohm's law and Kirchhoff's laws.
3. Circuit
  - (a) with one lamp controlled by one switch and provision of 2-pin or 3-pin socket PVC surface conduit system.
  - (b) With two lamps controlled by two switches with PVC surface conduit system.
  - (c) for Stair case wiring and Godown wiring.
4. Measurement of Power factor and its improvement.
5. Load test on 1-Phase Transformer.
6. Brake test on 3-Phase Induction Motor.
7. Brake test on 1- phase induction motor.
8. VI Characteristics of PN and Zener Diodes.
9. Ripple factor and load regulations of rectifier with and without filters.
10. Input and output characteristics of CE configuration.
11. Design of inverting and non-inverting amplifiers using op-amp.
12. Design of voltage summer and integrator using op-amp.
13. Soldering practice.

#### REFERENCE BOOKS/ LAB MANUALS:

1. P. S. Dhogal, *Basic Practicals in Electrical Engineering*, Standard Publishers, 2004.
2. Yannis Tsvividis, *A First Lab in Circuits and Electronics*, Wiley, 1<sup>st</sup> edition, 2001.

**ADDITIONAL LEARNING RESOURCES:**

1. [www.vlab.co.in](http://www.vlab.co.in), Virtual Electric Circuits Lab, A initiative of MHRD under NMEICT.
2. [www.vlab.co.in](http://www.vlab.co.in), Basic Electronics Lab, A initiative of MHRD under NMEICT.
3. <https://nptel.ac.in/courses/117106108/>
4. <https://ocw.mit.edu/high-school/physics/exam-prep/electric-circuits/>
5. <https://nptel.ac.in/courses/108105017/>
6. <https://nptel.ac.in/courses/108108112/>
7. <https://nptel.ac.in/courses/117107094/>

## I B. Tech. – II Semester

### (19BT20331) ENGINEERING WORKSHOP

(Common to CE, ME, CSE, CSSE, IT, CSE (AI) and CSE (DS))

| Int. Marks | Ext. Marks | Total Marks | L | T | P | C |
|------------|------------|-------------|---|---|---|---|
| 50         | 50         | 100         | - | - | 2 | 1 |

#### PRE-REQUISITES: --

**COURSE DESCRIPTION:** Knowledge on various workshop hand and power tools; hands on experience in different manufacturing trades such as fitting, carpentry, sheet metal forming and foundry; Demonstration on dismantling and assembling of various two wheeler parts, power tools in machining and metal joining, basics of plumbing and working of 3D printer.

**COURSE OUTCOMES:** After successful completion of the course, students will be able to:

- CO1. Design and model various basic prototypes in the trade of fitting such as square/half round mating, V- mating and dovetail mating from the given MS work pieces using fitting tools.
- CO2. Develop different prototypes in the carpentry trade such as cross lap joint, dovetail / bridle joints and Mortise and Tenon joint using carpentry tools.
- CO3. Design and model different prototypes in the sheet metal forming trade such as rectangular tray, square vessel/cylinder, Funnel as per the dimensions using sheet metal forming tools.
- CO4. Develop sand mold using single piece pattern and split piece pattern in the foundry trade using foundry tools.
- CO5. Demonstrate the knowledge on automobile parts, power tools, plumbing operation, 3D printing technology involved in different engineering applications.
- CO6. Work independently / in groups & communicate effectively in oral and written forms.

#### DETAILED SYLLABUS:

**FITTING:** Conduct a detailed study on various aspects in fitting trade which includes the details of fitting operations, safety precautions, types of tools, tool holders, miscellaneous tools, care and maintenance of hand tools, marking and measurement tool, and finishing tool.

#### List of Exercises:

1. Make a square/half round mating from the given MS work pieces
2. Make a V- mating from the given MS work pieces
3. Make a dovetail mating from the given MS work pieces

**CARPENTRY:** Conduct a detailed study on various aspects in carpentry trade which includes the details of types of wood, carpentry tools, wood working techniques, types of joints, safety precautions, and care and maintenance of tools.



**List of Exercises:**

4. Prepare a cross lap joint
5. Prepare dovetail / bridle joints
6. Prepare a Mortise and Tenon joint.

**SHEET METAL FORMING:** Conduct a detailed study on various aspects in sheet metal forming which includes the details of sheet materials, handtools, sheet metal fabrication, and safety and precautions

**List of Exercises:**

7. Fabricate a rectangular tray as per the dimensions
8. Fabricate square vessel/cylinder as per the dimensions
9. Fabricate a Funnel as per the dimensions

**FOUNDRY:** Conduct a detailed study on various aspects in foundry which includes the details of moulding sand, properties of moulding sand, types of patterns and pattern, materials, foundry tools, and safety and precautions

**List of Exercises:**

10. Prepare a sand mold, using the given single piece pattern (stepped pulley/cube)
11. Prepare a sand mold, using the given split piece pattern (pipe bent/dumbbell)

**DEMONSTRATION:**

12. Demonstrate the dismantling and assembling of various two wheeler parts
13. Demonstrate the usage of power tools.
14. Demonstrate the plumbing operation and identify the essential tool and materials required for plumbing.
15. Demonstrate the working of 3D printer

Note: Student shall perform any **Twelve Exercises**

**REFERENCE BOOKS/LABORATORY MANUALS:**

1. P. Kannaiah and K. L. Narayana, *Workshop Manual*, SciTech Publishers, 2009.
2. K. Venkata Reddy, *Workshop Practice Manual*, BS Publications, 2008.
3. V. Ramesh Babu, *Engineering Workshop Practice*, V R B Publishers Private Limited, 2009.

**ADDITIONAL LEARNING RESOURCES:**

1. R. K. Jain, *Production Technology*, Khanna Publishers, 17<sup>th</sup> edition, 2012.
2. Kalpakjian, Serop, *Manufacturing Engineering and Technology*, Pearson Education, 7<sup>th</sup> edition, 2014.

## I B. Tech. – II Semester

### (19BT21531) OBJECT ORIENTED PROGRAMMING THROUGH JAVA LAB

(Common to CSE, CSSE, IT, CSE (AI) and CSE (DS))

| Int. Marks | Ext. Marks | Total Marks | L | T | P | C |
|------------|------------|-------------|---|---|---|---|
| 50         | 50         | 100         | - | 1 | 2 | 2 |

**PRE-REQUISITES:** A course on OOPS through Java.

**COURSE DESCRIPTION:** Hands-on experience on Polymorphism; Inheritance and Interfaces; Exception Handling; Multithreading; Event Handling; Applets, swings.

**COURSE OUTCOMES:** After successful completion of the course, students will be able to:

**CO1.** Apply syntactic constructs of the JAVA programming language to solve logic based problems

**CO2.** Develop application programs using concepts of object oriented programming.

**CO3.** Function effectively as an individual and on teams to solve problems with effective communication.

CO4. Write and prepare mini project reports/ documents effectively.

#### LIST OF EXERCISES:

- 1 Demonstrate the following programs using command line arguments:
  - A Write a program that computes the sum of all its integer arguments
  - B Write a program to input n integers and perform sorting between them.
- 2 A The Fibonacci sequence is defined by the following rule. The first 2 values in the sequence are 0, 1. Every subsequent value is the sum of the 2 values preceding it. Write a Java program that uses both recursive and non-recursive functions to print the nth value of the Fibonacci sequence?
  - B Write a program to define a class student with name, registration number and marks for three subjects as instance variables and describe a constructor to initialize them. Also define a method display to print all the values.
- 3 A Write a program to print the element of an array that has occurred highest number of times.
  - B Write a program that displays a menu with options 1. Add 2. Sub. Based on the options chosen, read 2 numbers and perform the relevant operation. After performing the operation, the program should ask the user if he wants to continue. If the user presses y or Y, then the program should continue displaying the menu else the program should terminate. [Use Scanner class]
- 4 A Write a Program to count tokens- number of words and characters in a string.
  - B Write and test overloaded methods to find sum of three integers, sum of three double values and sum of four integers.
- 5 A Write a program to create an abstract class named Shape that contains an empty method named number of Sides ( ). Provide three classes named Trapezoid, Triangle and Hexagon such that each one of the classes extends the class Shape. Each one of the classes contains only the method numberOfSides ( ) that shows the number of sides in the given geometrical figures.
  - B Write a program that imports the User-defined package P1 and access the member variables and methods of classes that contained in the package P1.
- 6 A University awards some grace marks to students who participate in the Inter University games. Therefore, total marks awarded = Exam\_Marks +Sports\_Grace\_Marks. If total marks scored are greater than maximum marks, then the final marks awarded will be equal to the maximum marks. An Object Oriented based implementation will contain a class called Results, which extends a class called Exam, which itself extends a class called Student. It will also contain

- an interface called Sports, which is implemented by the Results class. The Results class will be responsible for computing the final marks scored by the students. Write a Java program along with an interactive driver class.
- 7 A Write a program to handle ArithmeticException, ArrayOut of BoundsException using try and multiple catch statements.
  - B Write a java program to throw a user defined exception called Negative, if the entered input is a negative number.
  - 8 A Write a Java program that creates three threads. First thread displays - Good Morning for every one second, the second thread displays - Hello for every two seconds and the third thread displays - Welcome for every three seconds.
  - B Write a Java program that correctly implements producer consumer problem using the concept of inter-thread communication.
  - 9 A Write a program create a class "Book" with name, id, author, publisher and quantity as instance variables and a constructor to initialize them. Create a HashSet object of type Book and three Book instances b1, b2 and b3. Add these instances into HashSet and display them.
  - B Develop an Applet that receives an integer in one text field, and computes its factorial value and returns it in another text field, when the button named "Compute" is clicked.
  - 10 A Write a program that creates a user interface to perform integer divisions. The user enters two numbers in the text fields Num1 and Num2. The division of Num1 and Num2 is displayed in the Result field when the Divide button is clicked. If Num1 or Num2 were not an integer, the program would throw a NumberFormatException. If Num2 were Zero, the program would throw an ArithmeticException Display the exception in a message dialog box.
  - B Write a java program that simulates a traffic light. The program lets the user select one of three lights: red, yellow, or green. When a radio button is selected, the light is turned on, and only one light can be on at a time No light is on when the program starts.
  - 11 Write a java program that handles all mouse and key events and shows the event name at the center of the window when mouse event is fired (Use Adapter classes).

### Mini Project 1:

Given coordinates of the box, radius of the circle and color, using these elements design an animation of a bouncing ball using Java applet program.

### Mini Project 2:

Design and implement a simple Inventory Control System for a small Video Rental Store using appropriate User-Interface. Define the following classes: **Video** to model a video and **VideoStore** to model the actual store. Assume following are the attributes of the class **Video**: title, user\_rating, a flag to say whether it is checked out or not and define required member methods. The **VideoStore** class will contain an instance variables that refers an array of videos (say of length 10) and the following member functions: addVideo(String), checkout(String), returnVideo(String), receiveRating(String) and listInventory(). Finally create a **VideoStoreLauncher** class with a main method which will test the functionality.

### REFERENCE BOOKS:

1. Herbert Schildt, *Java the Complete Reference*, Ninth Edition, Oracle Press, 2014.
2. Sachin Malhotra and Saurab Choudhary, *Programming in Java*, Second Edition, Oxford University Press, 2014.

### SOFTWARES/Tools used:

Java SE 12.0.1

### ADDITIONAL LEARNING RESOURCES

Problems to be considered from Hackerearth and CodeChef platforms

## I B. Tech. - II Semester

### (19BT1AC01) SPOKEN ENGLISH

(Audit Course)

(Common to CE, ME, CSE, CSSE, IT and CSBS)

| Int. Marks | Ext. Marks | Total Marks | L | T | P | C |
|------------|------------|-------------|---|---|---|---|
| -          | -          | -           | 2 | - | - | - |

**PRE-REQUISITES:** -

**COURSE DESCRIPTION:** Functional English; Vocabulary Building; Functional Grammar-I; Functional Grammar – II; Communication Skills.

**COURSE OUTCOMES:** After successful completion of the course, students will be able to:

**CO1. Demonstrate knowledge of grammar and vocabulary in writing effective formal letters and e-mails.**

**CO2. Communicate effectively by applying appropriate speaking and writing techniques by examining and applying functional English.**

**DETAILED SYLLABUS:**

**UNIT I - FUNCTIONAL ENGLISH: (6 Periods)**

Introduction - Functional Spoken English; Self Introduction; **Listening – Speaking:** Do's and Don'ts; **Expressing:** Ability / Admiration / Agreement / Annoyance / Appreciation / Pleasure / Sarcasm / Satisfaction / Surprise / Approval / Certainty/ Doubt / Gratitude / Possibility / Fear / Worry / Condolences; **Asking for:** Advice / Clarification / Direction / Information / Permission; **Making:** Predictions / recommendations.

**UNIT II - VOCABULARY BUILDING: (6 Periods)**

Introduction: Vocabulary for day-to-day conversations; Vegetables / Groceries / Fruits / Weather; Parts of a Human body / Dresses / Furniture / Relations; Birds / Cries of Animals; Food / Hospitality / Houses / Rooms / Tools; Airport / News Paper / Books / Gems; Corporate Vocabulary / Jobs / Occupations / Diseases; British / American spelling; Slang Words and Technical Jargon.

**UNIT III -FUNCTIONAL GRAMMAR - I: (6 Periods)**

Parts of Speech, Verb forms; Tenses; Voice; Speech.

**UNIT IV -FUNCTIONAL GRAMMAR - II: (6 Periods)**

Universal Auxiliaries; Sentence Structure - WH - Questions - How to frame Questions and give answers; Question Tags; Subject and verb agreement; Spotting Errors.

**UNIT V –COMMUNICATION SKILLS: (6 Periods)**

Polite, Courteous and Diplomatic expressions; Good Manners and Etiquette; Conversation Techniques; Narrating Stories.

**Total Periods: 30**

**Topics for self-study are provided in the lesson plan**

**TEXT BOOKS:**

1. L. Adinarayana and V. Prakasam, *Spoken English*, Neelkamal Publications Pvt. Ltd., New Delhi, 2008.
2. Ram Bhasker Raju, *The Complete Book on Spoken English*, Goutham Buddha Publications, Hyderabad, 2002.

**REFERENCE BOOKS:**

1. Sabina Pillai, *Spoken English for my World*, Oxford University Press, New Delhi, 2016.
2. K. R. Lakshminarayanan, *Speak in English*, Scitech Publications, Chennai, 2009.

**ADDITIONAL LEARNING RESOURCES**

- <https://www.britishcouncil.in/programmes/english-partnerships/state/skills-projects/AP-English-Skills>.
- <https://www.fluentu.com/blog/english/websites-to-learn-english>

## II B. Tech. - I Semester

### (19BT3BS01) NUMERICAL METHODS, PROBABILITY AND STATISTICS

(Common to CE, ME, CSE, CSSE and IT)

| Int. Marks | Ext. Marks | Total Marks | L | T | P | C |
|------------|------------|-------------|---|---|---|---|
| 40         | 60         | 100         | 3 | 1 | - | 4 |

**PRE-REQUISITES:** --

**COURSE DESCRIPTION:** Numerical solutions of equations; interpolation; Numerical differentiation and integration; Random variables; Mathematical expectations; Probability distributions; Test of hypothesis.

**COURSE OUTCOMES:** After successful completion of the course, students will be able to:

**CO1.** Analyse the data and develop skills to solve equations and integrals by applying numerical methods.

**CO2.** Demonstrate knowledge in statistics and analyse the data for validations by applying statistical testing methods and distributions.

**DETAILED SYLLABUS:**

#### **UNIT- I: NUMERICAL SOLUTIONS OF EQUATIONS AND INTERPOLATION**

**(8 Periods)**

Solutions of algebraic and transcendental equations: Regula-falsi method, Newton-Raphson method; Interpolation: Forward and backward differences, interpolation using Newton's forward and backward difference formulae, Lagrange's interpolation formula, partial fractions using Lagrange's interpolation formula.

#### **UNIT- II: NUMERICAL DIFFERENTIATION AND INTEGRATION**

**(9 Periods)**

Numerical differentiation using Newton's forward and backward interpolation formulae; Numerical integration using Simpson's  $1/3^{\text{rd}}$  and  $3/8^{\text{th}}$  rules; Numerical solutions of first order ordinary differential equations using Taylor's series method, fourth order Runge-Kutta method.

#### **UNIT- III: RANDOM VARIABLES AND MATHEMATICAL EXPECTATIONS**

**(8 Periods)**

Random Variables: Discrete and continuous random variables, distribution function of random variable, properties, probability mass function, probability density function; mathematical expectation, properties of mathematical expectation, mean and variance.

#### **UNIT- IV: PROBABILITY DISTRIBUTIONS**

**(9 Periods)**

Discrete probability distributions: Binomial, Poisson- mean, variance, standard deviation (without derivations); Continuous probability distributions: Normal, uniform and exponential distributions- mean, variance, standard deviation (without derivations), area under the normal curve.

**UNIT- V: TEST OF HYPOTHESIS****(11 Periods)**

Population and sample, parameter and statistic, null and alternative hypothesis, Type I and Type II errors, level of Significance, critical region, degrees of freedom; Large sample test: Tests of significance for proportions and means; Small sample test: Student's t-test- single mean, difference of means; F-test for equality of population variance; Chi-Square test for independence of attributes.

**Total Periods: 45*****Topics for self-study are provided in the lesson plan*****TEXT BOOKS:**

1. T. K. V. Iyengar, B. Krishna Gandhi, S. Ranganatham and M. V. S. S. N. Prasad, *Mathematical Methods*, S. Chand & Company, 5<sup>th</sup> edition, 2016.
2. T. K. V. Iyengar, B. Krishna Gandhi, S. Ranganatham and M. V. S. S. N. Prasad, *Probability and Statistics*, S. Chand & Company, 5<sup>th</sup> edition, 2016.

**REFERENCE BOOKS:**

1. B. S. Grewal, *Higher Engineering Mathematics*, Khanna Publishers, 44<sup>th</sup> edition, 2017.
2. P. Kandasamy, K. Thilagavathy, K. Gunavathi, *Numerical Methods*, S. Chand and Company, 2<sup>nd</sup> edition, Reprint 2012.
3. S. C. Gupta and V. K. Kapoor, *Fundamentals of Mathematical Statistics*, Sultan Chand and Sons Publications, 11<sup>th</sup> edition, 2012.

## II B. Tech. - I Semester

### (19BT31201) DISCRETE MATHEMATICAL STRUCTURES

(Common to CSE, CSSE and IT)

| Int. Marks | Ext. Marks | Total Marks | L | T | P | C |
|------------|------------|-------------|---|---|---|---|
| 40         | 60         | 100         | 3 | - | - | 3 |

**PRE-REQUISITES:** A course on "Transformation Techniques and Linear Algebra"

**COURSE DESCRIPTION:** Mathematical logic; Predicates; Relations; Algebra structures; Mathematical reasoning; Recurrence relations; Graphs; Graph theory and its applications.

**COURSE OUTCOMES:** After successful completion of the course, students will be able to:

- CO1. Demonstrate knowledge on mathematical logic and predicates.
- CO2. Analyze sets using functions and relations.
- CO3. Analyze properties of different algebraic structures.
- CO4. Apply mathematical reasoning, recurrence relations, permutations and combinations to solve computational problems.
- CO5. Apply concepts of graph theory and trees to implement computer applications.

#### DETAILED SYLLABUS:

##### UNIT- I: MATHEMATICAL LOGIC AND PREDICATES (10 Periods)

**Mathematical Logic:** Statements and notations, Connectives, Well formed formulae, Truth tables, Tautology, Equivalence of formulae, Normal forms.

**Predicates:** Predicate calculus, Free and Bound variables, Rules of inference, Consistency, Proof of contradiction and Automatic Theorem Proving.

##### UNIT- II: FUNCTIONS AND RELATIONS (9 Periods)

**Relations:** Properties of binary relations, Equivalence relations, Compatibility relations, Partial ordering relations, Hasse diagram and related applications.

**Functions:** Inverse Functions, Composition of functions, Recursive functions, Lattice and its Properties.

##### UNIT- III: ALGEBRAIC STRUCTURES (7 Periods)

**Algebraic System:** Examples and General Properties, Semi Groups and Monoids, Groups, Subgroups, Homomorphism and Isomorphism.

##### UNIT- IV: MATHEMATICAL REASONING AND RECURRENCE RELATIONS

(10 Periods)

**Mathematical Reasoning:** Methods of Proof, Mathematical Induction, Basics of counting, The Inclusion-Exclusion Principle, The Pigeon hole principle, Permutations and Combinations, Generalized Permutations and Combinations.

**Recurrence Relations:** Generating Functions of Sequences, Calculating coefficients of generating function, Recurrence relation, solving recurrence relations by substitution and



Generating functions, Methods of Characteristic Roots, Solutions of Inhomogeneous Recurrence Relation.

**UNIT- V: GRAPH THEORY AND ITS APPLICATION (9 Periods)**

**Graphs:** Introduction to Graphs, Types of Graphs, Graph basic terminology and Special types of simple graphs, Representation of Graphs and Graph Isomorphism, Euler Paths and Circuits, Hamiltonian Paths and Circuits, Planar Graphs, Euler's Formula and Graph Coloring.

**Trees:** Introduction to Trees, Properties of Trees, Applications of Trees, Spanning Trees, Counting trees, Depth-First Search, Breadth-First Search, Minimum Spanning Trees, Kruskal's Algorithm and Prim's Algorithm.

**Total Periods: 45**

**Topics for self-study are provided in the lesson plan**

**TEXT BOOKS:**

1. J.P. Trembly and R. Manohar, *Discrete Mathematical Structures with Applications to Computer Science*, Tata McGraw Hill, Thirty Seventh Edition, 2017.
2. Kenneth H. Rosen, *Discrete Mathematics and its Applications*, Tata McGraw Hill, Sixth Edition, 2007.

**REFERENCE BOOKS:**

1. Joe L. Mott and Abraham Kandel, *Discrete Mathematics for Computer Scientists and Mathematicians*, Prentice Hall of India Private Limited, Second Edition, 2004.
2. Ralph P. Grimaldi and B.V.Ramana, *Discrete and Combinatorial Mathematics - an Applied Introduction*, Pearson Education, Fifth Edition, 2006.

**ADDITIONAL LEARNING RESOURCES:**

1. <https://www.maa.org/press/ebooks/resources-for-teaching-discrete-mathematics>.
2. <https://www.quora.com/>

**II B. Tech. – I Semester**  
**(19BT31502) OPERATING SYSTEMS**  
 (Common to CSE and CSSE)

| Int. Marks | Ext. Marks | Total Marks | L | T | P | C |
|------------|------------|-------------|---|---|---|---|
| 40         | 60         | 100         | 3 | - | - | 3 |

**PRE-REQUISITES:** A course on “Computer Organization”

**COURSE DESCRIPTION:** Operating systems operations; Process scheduling; Process synchronization, Deadlocks; Paging and segmentation; Disk scheduling; File concepts, I/O interface; Concepts of protection and security.

**COURSE OUTCOMES:** After successful completion of the course, students will be able to:

- CO1. Analyze performance of CPU scheduling algorithms.
- CO2. Design solutions for process synchronization problems by using semaphores and monitors.
- CO3. Devise solutions for deadlocks using deadlock handling mechanisms.
- CO4. Solve memory management problems using page replacement and disk scheduling algorithms.
- CO5. Identify efficient file allocation methods for optimal disk utilization.
- CO6. Analyze services of I/O subsystems and mechanisms of security & protection.

**DETAILED SYLLABUS:**

**UNIT- I: INTRODUCTION TO OPERATING SYSTEM AND PROCESS MANAGEMENT**  
**(8 Periods)**

**Introduction:** Definition, Operating system structure and services: Layered approach, Hybrid systems :Mac OSX, iOS, Android, System calls.

**Process Management:** Process scheduling, Process control block, Inter process communication, Threads, Multithreading models, CPU scheduling criteria, Scheduling algorithms, Multiprocessor scheduling.

**UNIT- II: PROCESS SYNCHRONIZATION AND DEADLOCKS** **(10 Periods)**

**Process Synchronization:** Critical section problem, Peterson’s solution, Synchronization hardware, Semaphores, Synchronization problems, Monitors.

**Deadlocks:** System model, Deadlock characterization, Methods for handling deadlocks, Prevention, Detection, Avoidance, Recovery from deadlock.

**UNIT- III: MEMORY MANAGEMENT AND SECONDARY STORAGE** **(10 Periods)**

**Memory Management:** Swapping, Contiguous allocation, Paging, Segmentation, Segmentation with paging.

**Virtual Memory:** Demand paging, Page replacement algorithms, Copy-on-write, Thrashing.

**Secondary Storage Structure:** Overview of mass storage structure, Disk structure, Disk scheduling, Disk management.

**UNIT- IV: FILE AND I/O SYSTEMS****(8 Periods)**

**File System:** File concept, Access methods, Directory structure, File system structure, i-node, File system implementation, Directory implementation, Allocation methods.

**I/O System:** I/O hardware, Application I/O interface, Kernel I/O subsystem.

**UNIT- V: PROTECTION AND SECURITY****(9 Periods)**

**Protection:** Goals, Principles, Domain of protection, Access matrix, Implementation of access matrix, Access control, Revocation of access rights.

**Security:** Security problem, Program threats, System and network threats, User authentication, Implementing security defenses, Firewalling to protect systems and networks, Computer-security classifications.

**Total Periods: 45**

***Topics for self-study are provided in the lesson plan***

**TEXT BOOK(S):**

1. Abraham Silberschatz, Peter Baer Galvin and Greg Gagne, *Operating System Concepts*, Wiley India Edition, 9<sup>th</sup>Edition, 2016.

**REFERENCE BOOKS:**

1. William Stallings, *Operating Systems: Internals and Design Principles*, Pearson Education, 7<sup>th</sup>Edition, 2013.
2. Andrew S. Tanenbaum, *Modern Operating Systems*, PHI, 3<sup>rd</sup>Edition, 2009.

**II B. Tech. – I Semester**  
**(19BT30501) COMPUTER GRAPHICS**  
(Common to CSE and IT)

| Int. Marks | Ext. Marks | Total Marks | L | T | P | C |
|------------|------------|-------------|---|---|---|---|
| 40         | 60         | 100         | 3 | - | - | 3 |

**PRE-REQUISITES:** A course on “Transformation Techniques and Linear Algebra”

**COURSE DESCRIPTION:** Introduction to computer graphics; Output primitives; 2D geometric transformations and viewing; 3D geometric transformations and viewing; 3D object representation; Illumination models; Visible surface detection methods and rendering methods.

**COURSE OUTCOMES:** After successful completion of the course, students will be able to:

- CO1. Analyze raster scan and random scan systems by applying knowledge on graphical interactive devices.
- CO2. Design algorithms for output primitives such as lines, circles and filled area primitives to fill specified area.
- CO3. Analyze the concepts of geometrical transformations, representations, and viewing for 2D and 3D objects.
- CO4. Apply appropriate techniques for visible surface detection, illumination models and rendering methods.

**DETAILED SYLLABUS:**

**UNIT- I: INTRODUCTION AND OUTPUT PRIMITIVES (9 Periods)**

**Introduction to Graphics Systems:** Video display devices, Raster-scan systems, Random-scan systems, Graphics monitors and workstations, Input devices.

**Output Primitives:** Points and lines, Line drawing algorithms, Midpoint circle algorithm.

**UNIT- II: FILLED AREA PRIMITIVES AND 2D GEOMETRIC TRANSFORMATIONS (9 Periods)**

**Filled Area Primitives:** Scan-line polygon fill algorithm, Boundary-fill algorithm and Flood-fill algorithm.

**2D Geometric Transformations:** Transformations – translation, scaling, rotation, reflection and shear; Homogeneous coordinates, Composite transformations, Transformations between coordinate systems.

**UNIT- III: 2D VIEWING AND 3D OBJECT REPRESENTATIONS (9 Periods)**

**2D Viewing:** The viewing pipeline, Viewing coordinate reference frame, Window-to-viewport coordinate transformation, Cohen-Sutherland line clipping algorithm, Sutherland-Hodgeman polygon clipping algorithm.

**3D Object Representations:** Polygon surfaces, Quadric surfaces, Spline representations, Hermite curve, Bezier curves and surfaces.

**UNIT- IV: 3D GEOMETRIC TRANSFORMATIONS AND VIEWING (7 Periods)**

**3D Geometric Transformations:** Translation, Rotation, Scaling, Reflection and Shear.

**3D Viewing:** Viewing pipeline, Viewing coordinates, Projections and Clipping.

**UNIT-V:ILLUMINATION MODELS, VISIBLESURFACE DETECTION AND SURFACERENDERING METHODS (11 Periods)**

**Illumination Models:** Ambient Light and Diffuse Reflection.

**Visible Surface Detection Methods:** Classification, Back-face detection, Depth-buffer method, Scan-line method, Depth-sorting method and BSP-tree method.

**Surface Rendering methods:** Gouraud shading and Phong shading.

**Total Periods: 45**

*Topics for self-study are provided in the lesson plan*

**TEXT BOOK(S):**

1. Donald D. Hearn and M. Pauline Baker, *Computer Graphics C version*, Pearson Education, Second Edition, 2006.

**REFERENCE BOOKS:**

1. Fabio Ganovelli, Massimiliano Corsini, Sumanta Pattanaik, Marco Di Benedetto, *Introduction to Computer Graphics: A Practical Learning Approach*, CRC Press, 2014.
2. Apurva A. Desai, *Computer Graphics*, PHI Learning, 2008.
3. William M. Newman and Robert F. Sproull, *Principles of Interactive Computer Graphics*, McGraw-Hill, Second Edition, 2005.

**ADDITIONAL LEARNING RESOURCES:**

1. Sumanta Guha, *Computer Graphics through OpenGL*, CRC Press, Second Edition, 2015.
2. <https://nptel.ac.in/courses/106/106/106106090/>

## II B. Tech. - I Semester

### (19BT30502) COMPUTER ORGANIZATION

(Common to CSE, CSSE and IT)

| Int. Marks | Ext. Marks | Total Marks | L | T | P | C |
|------------|------------|-------------|---|---|---|---|
| 40         | 60         | 100         | 3 | - | - | 3 |

**PRE-REQUISITES:** A course on "Digital Logic Design"

**COURSE DESCRIPTION:** Basic structure and operation of a digital computer; Organization and functional principles of the arithmetic and logic unit, control unit, memory unit and I/O unit; Concepts of pipelining and parallel processing techniques; Multicore computers.

**COURSE OUTCOMES:** After successful completion of the course, students will be able to:

- CO1. Analyze computer arithmetic algorithms for fixed-point and floating-point binary operations.
- CO2. Analyze the architecture, organization and functions of the components of a digital computer.
- CO3. Design digital circuits for the given functional description of micro operations and memory elements.
- CO4. Investigate the performance of memory systems, I/O systems, pipelined processors and multiprocessors to evaluate the cost-performance trade-offs.

#### DETAILED SYLLABUS:

#### UNIT-I: COMPUTER ARITHMETIC, REGISTER TRANSFER AND MICROOPERATIONS (9 Periods)

**Computer Arithmetic:** Fixed point representation, Floating point representation, Addition and subtraction, Binary multiplication algorithms.

**Register Transfer and Microoperations:** Register transfer, Bus and memory transfers, Arithmetic microoperations, Logic microoperations, Shift microoperations, Arithmetic logic shift unit.

#### UNIT- II: BASIC COMPUTER ORGANIZATION AND DESIGN (8 Periods)

Instruction codes, Computer registers, Computer instructions, Instruction formats, Addressing modes, Timing and control, Instruction cycle, Input-Output and Interrupt.

#### UNIT-III: MICRO PROGRAMMED CONTROL AND INPUT-OUTPUT ORGANIZATION (10 Periods)

**Micro Programmed Control:** Control memory, Address sequencing, Design of control unit, Hardwired control, Micro programmed control.

**Input-Output Organization:** Peripheral devices, Input-Output interface, Modes of transfer, Priority interrupt – Daisy chaining priority, Parallel priority interrupt, Priority encoder; Direct Memory Access, Input-Output Processor – CPU-IOP communication; PCI Express - PCI physical and logical architecture.

**UNIT- IV: THE MEMORY SYSTEM****(9 Periods)**

Semiconductor RAM memories – Internal organization, Static memories, Dynamic RAMs, Synchronous and Asynchronous DRAMs, Structure of larger memories; Read-only memories, Cache memories – Mapping functions; Nonvolatile Solid-State Memory Technologies, Solid state drives.

**UNIT-V: PIPELINE AND VECTOR PROCESSING, MULTIPROCESSORS, MULTICORE COMPUTERS****(9 Periods)**

**Pipeline and Vector Processing:** Parallel processing, Pipelining, Instruction pipeline, Vector processing, Array processors.

**Multiprocessors:** Characteristics of multiprocessors, Interconnection structures, Inter-processor arbitration.

**Multicore Computers:** Hardware performance issues, Software performance issues, Multicore organization, Intel Core i7-990X.

**Total Periods: 45**

*Topics for self-study are provided in the lesson plan*

**TEXT BOOKS:**

1. M. Morris Mano, Rajib Mall, *Computer System Architecture*, Revised 3<sup>rd</sup> Edition, Pearson Education, 2017.
2. Carl Hamacher, Zvonko Vranesic, SafwatZaky, Naraig Manjikian, *Computer Organization and Embedded Systems*, 6<sup>th</sup> Edition, McGraw Hill, 2012.

**REFERENCE BOOKS:**

1. William Stallings, *Computer Organization and Architecture: Designing for Performance*, 11<sup>th</sup> Edition, Pearson Education, 2018.
2. Andrew S. Tanenbaum, Todd Austin, *Structured Computer Organization*, 6<sup>th</sup> Edition, Pearson, 2016.

**ADDITIONAL LEARNING RESOURCES:**

- <https://nptel.ac.in/courses/106105163/>
- Bilkent Online Courses, Bilkent University, Lectures by William Sawyer, <https://www.youtube.com/watch?v=CDO28Esqmcg>

**II B. Tech. - I Semester**  
**(19BT30503) DATA STRUCTURES**

(Common to CSE and IT)

| Int. Marks | Ext. Marks | Total Marks | L | T | P | C |
|------------|------------|-------------|---|---|---|---|
| 40         | 60         | 100         | 3 | 1 | - | 4 |

**PRE-REQUISITES:** A course on "Object Oriented Programming through Java"

**COURSE DESCRIPTION:** Introduction to data structures; Linked Lists; Types of lists; Stacks; Queues; Trees; Binary search trees; AVL trees; Red-Black Trees; Searching algorithms; Sorting algorithms; Graphs; Minimum spanning trees; Hashing.

**COURSE OUTCOMES:** After successful completion of the course, students will be able to:

- CO1. Analyze linear data structures such as arrays, linked lists, stacks, queues for efficient data organization and manipulation.
- CO2. Analyze data structures such as trees, graphs, hash tables for efficient search and retrieval of data.
- CO3. Select and apply appropriate techniques for searching and sorting problems.
- CO4. Apply knowledge to select appropriate data structures for modeling information in data.

**DETAILED SYLLABUS:**

**UNIT- I: LINKED LISTS (7 Periods)**

Overview of data structures and algorithms, Linear and non-linear data structures, Big O notation, Linked lists – Definition, Operations; Single linked lists, Circular linked lists, Doubly linked lists, Sorted lists, Linked lists efficiency, Applications of linked lists.

**UNIT- II: STACKS AND QUEUES (9 Periods)**

**Stacks:** Definition, Operations, Implementation using arrays and linked lists, Applications – Reversing a word, Delimiter matching, Parsing arithmetic expressions.

**Queues:** Definition, Operations, Applications, Implementation using arrays and linked lists, Circular queue, Double-ended queues, Priority queues.

**UNIT- III: BINARY TREES AND SEARCH TREES (11 Periods)**

Tree terminology, Binary trees, Trees represented as arrays, Binary search trees - Concepts, Advantages, Operations, Finding maximum and minimum values, Efficiency; Balanced and unbalanced trees, AVL search trees – Concepts, Operations; Red-Black trees – Concepts, Rotations, Inserting a node, Efficiency.

**UNIT- IV: SEARCHING AND SORTING (9 Periods)**

**Searching:** Linear search, Binary search.

**Sorting:** Bubble sort, Selection sort, Insertion sort, Sorting objects, Shell sort, Partitioning, Quick sort, Merge sort, Heap sort.



**UNIT- V: GRAPHS AND HASHING****(9 Periods)**

**Graphs:** Concepts, Representation, Operations, Depth-first search, Breadth-first search, Minimum spanning trees.

**Hashing:** Introduction, Open addressing, Separate chaining, Characteristics of good hash functions – Quick computation, Random and Non-random keys, Folding; Hashing efficiency.

**Total Periods: 45**

**Topics for self-study are provided in the lesson plan**

**TEXT BOOK(S):**

1. Robert Lafore, *Data Structures & Algorithms in Java*, 2<sup>nd</sup> Edition, Pearson, 2007.

**REFERENCE BOOKS:**

1. Goodrich, Tamassia, Goldwasser, *Data structures & Algorithms in Java*, 6<sup>th</sup> Edition, Wiley, 2014.
2. John R. Hubbard, *Programming with Java*, 2<sup>nd</sup> Edition, McGraw Hill, 2009.
3. Debasis Samanta, *Classic Data Structures*, 2<sup>nd</sup> Edition, Prentice Hall, 2009.

**ADDITIONAL LEARNING RESOURCES:**

- <http://www.nptel.ac.in/courses/106102064>
- <http://nptel.ac.in/courses/106106127/>
- <https://ocw.mit.edu/courses/electrical-engineering-and-computer-science/6-006-introduction-to-algorithms-fall-2011/lecture-videos>

**II B. Tech. – I Semester**  
**(19BT31532) OPERATING SYSTEMS LAB**  
(Common to CSE and CSSE)

| Int. Marks | Ext. Marks | Total Marks | L | T | P | C |
|------------|------------|-------------|---|---|---|---|
| 50         | 50         | 100         | - | - | 2 | 1 |

**PRE-REQUISITES:** A course on "Operating Systems"

**COURSE DESCRIPTION:** Hands-on practice in simulating algorithms for CPU scheduling; Memory management; I/O management; Deadlock handling mechanisms; Implementing synchronization problems.

**COURSE OUTCOMES:** *After successful completion of the course, students will be able to:*

- CO1. Analyze process scheduling problems by applying contextual knowledge on CPU scheduling algorithms.
- CO2. Apply memory management and disk scheduling algorithms to attain optimal solutions.
- CO3. Devise solution for deadlock avoidance using banker's algorithm.
- CO4. Design solutions for process synchronization problems using semaphores and monitors.
- CO5. Apply file allocation strategies to achieve optimal disk utilization.
- CO6. Work independently and in team to solve problems with effective communication.

**LIST OF EXERCISES:**

1. Simulate the following:  
a) Process System Calls  
b) I/O System Calls
2. Simulate multi-level queue scheduling algorithm by considering the following scenario. All the processes in the system are divided into two categories – system processes and user processes. System processes are to be given higher priority than user processes. The priority of each process ranges from 1 to 3. Use fixed priority scheduling for all the processes.
3. Demonstrate File Permissions.
4. Simulate the following CPU Scheduling Algorithms:  
a) FCFS  
b) SJF (Preemptive)  
c) Priority  
d) Round Robin
5. Design solutions for the following synchronization problems:  
a) Producer Consumer Problem  
b) Dining Philosophers Problem
6. Design Banker's Algorithm for Deadlock Avoidance. Find the safe sequence. If Maximum request of any one process is changed, detect whether a deadlock has occurred or not. Consider the number of resources are three and Jobs are five.
7. Simulate the following Algorithms:  
a) First Fit  
b) Best Fit  
c) Worst Fit

8. Simulate the following Page Replacement Algorithms:  
a) FIFO b) LFU c) LRU d) Optimal
9. Simulate the following Disk Scheduling Algorithms  
a) FCFS b)SSTF c) SCAN d) CSCAN
10. Simulate the following file allocation strategies:  
a) Contiguous Allocation b) Linked Allocation

**REFERENCE BOOKS:**

1. Herbert Schildt, *Java the Complete Reference*, Ninth Edition, Oracle Press, 2014.
2. Sachin Malhotra and Saurab Choudhary, *Programming in Java*, Second Edition, Oxford University press, 2014.

**SOFTWARE/TOOLS USED:**

- Software: J2SDK 1.7
  - Eclipse or Net bean
- Java compatible web browser

**II B. Tech. - I Semester**  
**(19BT30531) DATA STRUCTURES LAB**  
(Common to CSE and IT)

| Int. Marks | Ext. Marks | Total Marks | L | T | P | C |
|------------|------------|-------------|---|---|---|---|
| 50         | 50         | 100         | - | - | 2 | 1 |

**PRE-REQUISITES:**A course on "Data Structures"

**COURSE DESCRIPTION:** Hands on practice on implementation of Linked lists; Arrays; Stacks; Queues; Search algorithms; Sorting algorithms; Binary search tree representation and operations; Graph representation and operations; Hashing functions.

**COURSE OUTCOMES:** After successful completion of the course, students will be able to:

- CO1. Implement linear data structures such as arrays, linked lists, stacks, queues for efficient data organization and manipulation.
- CO2. Develop solutions using data structures such as trees, graphs, heaps, hash tables for efficient search and retrieval of data.
- CO3. Select and apply appropriate techniques for searching and sorting problems.
- CO4. Work independently and communicate effectively in oral and written forms.

**LIST OF EXERCISES:**

1. A college has N number of students and the following details of all the students are maintained – register number, name, branch, phone number. Write a program to store the details of the students using a singly linked list. Develop functions to perform the following operations on the data.
  - a) Insert new student's details
  - b) Display the details of the students
  - c) Display the total number of students
  - d) Delete a given student's information
2. Department of CSE has readers club named 'Aalochana'. Students can be granted membership in readers club on their request. Similarly, one may cancel their membership of the club. Members of the club can rent books from the club. Write a program to create data structure to maintain readers club members information (Hall ticket number, name) using singly linked list. In singly linked list, the header node should store details of head of readers club and last node should store details of in-charge of readers club. Develop functions to perform the following operations on the data.
  - a) Store details of head and in-charge of the readers club
  - b) Grant and cancel memberships of students
  - c) Display total number of members
  - d) Display the details of the members
  - e) Display the sorted list of details of the members (sort based on their names in alphabetical order)
3. A company has N number of employees and it maintains the following details of each of its employees: ID, department, salary, phone number. Develop a menu

driven program using doubly linked list to store the employees' data. Develop functions to perform the following operations on the data.

- a) Add and delete employees
  - b) Display total number of employees
  - c) Display details of employees with salary more than Rs. 50,000
  - d) Display the phone number of the employee given the ID
4. a) Develop a menu driven program to perform the following operations on a stack of integers (Array and linked list implementations of stack with maximum size MAX)
- i) Push an element
  - ii) Pop an element
  - iii) Display the status
  - iv) Demonstrate overflow and underflow situations (in array implementation)
- b) Write a program to check whether a string is palindrome or not using stack data structure.
- c) Mostly syntax errors in a computer program arise due to unbalanced braces (such as (), {}, []). Write a program using stack to check whether a given expression has balanced braces or not.
5. a) Develop a menu driven program to perform the following operations on a queue of characters (Array and linked list implementations of queue with maximum size MAX)
- i) Insert an element
  - ii) Delete an element
  - iii) Display the status
  - iv) Demonstrate overflow and underflow situations (in array implementation)
- b) A restaurant based on its human resources can accept a maximum of N number of food orders. The food orders are served in first come first serve basis. The food orders once placed cannot be cancelled. Write a program to simulate the food ordering and serving system in the restaurant using circular queue.
6. Write a program to perform the following operations on the binary search tree.
- a) Construct binary search tree by inserting the values {6, 9, 5, 2, 8, 15, 24, 14, 7, 8, 5, 2} in the given order.
  - b) Display the nodes of the tree using inorder, preorder and postorder traversal techniques.
  - c) Display the smallest number stored in the tree.
  - d) Search the tree for a given number.
7. There are train paths between cities. If there is a train between city A and city B then there is a route between the cities. The cost of the route is the distance between city A and city B. Represent the train travel route information as a graph. The node can be represented by the name of the city. Write a program to perform the following operations.
- a) Store the details of train travel route information using adjacency list or adjacency matrix representation.

- b) Traverse the graph and display the details of all trains between the cities along with the cost using breadth-first method.
  - c) Traverse the graph and display the details of all trains between the cities along with the cost using depth-first method.
8. Store register numbers of students who attended placement training program in a random order in an array. Write a function to search whether a student has attended placement training program or not using
    - a) Linear search
    - b) Binary search
  9. Write a program to sort a given set of integers using
    - a) Quick sort
    - b) Shell sort
  10. a) Write a program to sort a given set of integers using merge sort.  
b) Write a program to read the marks obtained by students in a mathematics examination and store the data using a heap data structure. Find out the maximum and minimum marks obtained by the students.
  11. Write a program to implement the following hashing functions.
    - a) Separate Chaining Method
    - b) Open Addressing Method
  12. Consider an online movie ticket booking system through which customers can book tickets to watch movies at theatres. The database stores the details of each transaction of ticket booking with the details - ID, customer name, customer phone number, movie name, theatre name, date of show, time of show, number of tickets booked, starting seat number, total amount. Write a menu driven program to perform create the database and given an ID, display a client's phone number. Use a hash table implementation to quickly search through the database.

**REFERENCE BOOKS:**

1. Robert Lafore, *Data Structures & Algorithms in Java*, 2<sup>nd</sup> Edition, Pearson, 2007.
2. Goodrich, Tamassia, Goldwasser, *Data structures & Algorithms in Java*, 6<sup>th</sup> Edition, Wiley, 2014.

**SOFTWARE/TOOLS USED:**

- Software: J2SDK 1.7
  - Eclipse or Net bean
- Java compatible web browser

## II B. Tech. - I Semester

### (19BT30532) WORKSHOP IN COMPUTER SCIENCE

| Int. Marks | Ext. Marks | Total Marks | L | T | P | C |
|------------|------------|-------------|---|---|---|---|
| 50         | 50         | 100         | - | - | 2 | 1 |

**PRE-REQUISITES:** A course on "Programming for Problem Solving"

**COURSE DESCRIPTION:** Hands on practice sessions on Google cloud productivity and collaboration tools; AI Tools for speech recognition, language detection and object detection; Introduction to GitHub; Programming in C language.

**COURSE OUTCOMES:** After successful completion of the course, students will be able to:

- CO1. Use Google productivity and collaboration tools for effective documentation and data sharing.
- CO2. Use AI tools for speech recognition, language detection and object detection.
- CO3. Use online code hosting platforms such as GitHub for hosting and collaborating software projects.
- CO4. Develop modular programs in C programming language to solve engineering problems.
- CO5. Work independently and communicate effectively in oral and written forms.

#### LIST OF EXERCISES:

##### Cloud Based Productivity and Collaboration Tools:

1. Introduction to Google drive, Google Backup & Sync, Google Docs, Google Forms.
  - a) Store, sync, and share files in the cloud using Google Drive, Google Backup & Sync tools.
  - b) Create and edit text documents online using Google Docs.
  - c) Create Google forms to manage event registrations/surveys/quizzes and analyze responses.

##### AI Tools:

2. Speech Recognition: Read an audio file with Python and use the Google speech recognition API to perform conversion of Speech to Text.
3. Language Detection: Detect the language of the text using language detection library (langdetect) ported from Google's language-detection.
4. Object Detection: Detect multiple objects present in an image using Detectron-Facebook's API.

##### GitHub:

5.
  - a) Introduction to GitHub basic concepts and Flow.
  - b) GitHub Installation and Setup.

- c) Create a "Hello World" project on GitHub by performing the following operations
- Create and use a repository
  - Create and manage a new branch
  - Perform and commit changes to a file
  - Open and merge pull requests

**Programming in C:**

The C Character set, Identifiers and Keywords, Data types, Constants, Variables, Declarations, Expressions, Statements, Operators, Datatypes, Input-Output statements, Control statements, Arrays, Strings, Functions, Structures.

6. a) Write a C program to solve the logical implication  $P \rightarrow Q = !P \wedge Q$ . Consider various combinations of binary values for P and Q.

**Hint:**

| P | Q | $!P \wedge Q$ |
|---|---|---------------|
| 0 | 0 | 0             |
| 0 | 1 | 1             |
| 1 | 0 | 0             |
| 1 | 1 | 0             |

- b) Mr. X is a superstitious person. He also likes to double everything he has been given and his lucky number is the one which is divisible by 2. Given a number, write a C program to find out whether the number is Mr. X's lucky number or not. Analyze the program carefully and find out test cases where the given input number is lucky and where the input number is not lucky.
7. a) Write a C program to evaluate the following expression.

$$Y = 1.5X^2 + 5 \quad \text{if } 0 \leq X \leq 2$$

$$Y = 2X^2 + 5 \quad \text{otherwise}$$

- b) The evaluation schema for a subject in an engineering course is as follows. There will be two mid-term examinations to be attended by the student. Student has to attempt an objective paper, essay paper and an assignment for each mid-term exam. The details of the division of marks for the exams is given in the following table. The final marks of the student in a subject is the sum of 80% of the best marks and 20% of the other out of the two mid-term examinations.

| Mid-Term Examination | Examination Schema | Max. Marks | Final Marks in the subject                           |
|----------------------|--------------------|------------|------------------------------------------------------|
| Mid-Term 1           | Objective Paper    | 10M        | 80% of the best mid-term + 20% of the other mid-term |
|                      | Essay Paper        | 10M        |                                                      |
|                      | Assignment         | 05M        |                                                      |
| Mid-Term 2           | Objective Paper    | 10M        |                                                      |
|                      | Essay Paper        | 10M        |                                                      |
|                      | Assignment         | 05M        |                                                      |

Given the marks of the student in each paper, write a C program to find out his final marks.



8. a) A pharmaceutical corporation is considering taking applicant interviews. The interviews will be offered to applicants who meet certain educational specifications. An applicant who meets any of the following criteria should be accepted for an interview:
- i) Graduates over 25 who studied chemistry and who did not graduate from X university.
  - ii) Graduates from X University who studied chemistry.
  - iii) Graduates from Y University who studied pharmacy and are not older than 28.
  - iv) Graduates from X University who are over 25 and who didn't study chemistry
- Hint: Use menu-based strategy to know the user's qualifications.
- b) Write a C program to confirm whether a person is Lardy or Hardy or None depending upon his height and weight.

| Height          | Weight            | Person |
|-----------------|-------------------|--------|
| 5' 5"           | 50kg to 60kg      | Lardy  |
| Less than 5' 5" | Greater than 90kg | Hardy  |
| Otherwise       |                   | None   |

9. a) a) Write a C program that takes in a class ID of a ship and displays the equivalent string class description of the given class ID. Use the details given in the table below.

| Class ID | Ship Class  |
|----------|-------------|
| B or b   | Battle Ship |
| C or c   | Cruiser     |
| D or d   | Destroyer   |
| F or f   | Frigate     |

- b) Given two rolling dices, write a C program to display all the possible output values when the dices are rolled. Hint: Each dice has values from 1 to 6.
10. Write a C program to read two strings and display their difference. Let the two strings be S1 and S2. Let the strings be of equal length 'n'. The difference between S1 and S2 is given as

$$\sum_{i=1}^n |S1_i - S2_i|$$

11. Department of Telecom is maintaining the following details for each of the customers: Customer Name, Telephone number, Phone Registration Address and Billing Address. Write a C program to read and store the details of all the customers. Develop a function to search for a given customer's details based on the telephone number.
12. Write a program in C to check whether two given strings are an anagram using functions.

**REFERENCE BOOKS:**

1. Pradip Dey and Manas Ghosh, *Programming in C*, 2<sup>nd</sup> Edition, Oxford University Press, 2007.

**SOFTWARE/TOOLS USED:**

- Google Cloud based productivity and collaboration tools
- Github
- Google speech recognition API, Google's language-detection API
- Detectron-Facebook's API
- GCC compiler

**ADDITIONAL LEARNING RESOURCES:**

- <https://gsuite.google.com/learning-center/products/#!/>
- <https://pypi.org/project/langdetect/>
- <https://cloud.google.com/translate/docs>
- <https://ai.facebook.com/tools/detectron/>

## II B.Tech. - I Semester

### (19BT315AC) DESIGN THINKING

(Audit Course)

(Common to CE, ME, CSE, CSSE and IT)

| Int. Marks | Ext. Marks | Total Marks | L | T | P | C |
|------------|------------|-------------|---|---|---|---|
| -          | -          | -           | 2 | - | - | - |

#### PRE-REQUISITES: --

**COURSE DESCRIPTION:** Design thinking process; Design thinking phases; Empathy tools; Idea generation, visualizing and empathizing; Fidelity for prototypes, Prototyping; Prototyping for physical products.

**COURSE OUTCOMES:** After successful completion of the course, students will be able to:

- CO1. Analyze design thinking concepts and principles to perform human centered design process for creative problem solving.
- CO2. Create empathy maps to visualize user attitudes and behavior for gaining insights of customers.
- CO3. Develop innovative products or services for a customer base using ideation techniques.
- CO4. Build prototypes for complex problems using gathered user requirements.
- CO5. Apply design thinking tools, techniques to produce good design and relevant products or services for a specific target market.
- CO6. Improve prototype by testing it with a specific set of users for making it sustainable by following ethics.

#### DETAILED SYLLABUS:

##### UNIT-I: INTRODUCTION TO DESIGN THINKING

(6 Periods)

Design Thinking Process: Types of the thinking process, Common methods to change the human thinking process, Design thinking: Definition, Origin of design thinking, Importance of design thinking, Design vs Design thinking, Problem solving, Understanding design thinking and its process model, Design thinking tools.

##### UNIT-II: EMPATHIZE

(6 Periods)

Design thinking phases, How to empathize, Role of empathy in design thinking, purpose of empathy maps, Things to be done prior to empathy mapping, Activities during and after the session, Understanding empathy tools : Customer Journey Map, Personas.

##### UNIT-III: IDEATION

(6 Periods)

Challenges in idea generation, need for systematic method to connect to user, Visualize, Empathize, and Ideate method, Importance of visualizing and empathizing before ideating, Applying the method, Ideation Tools: How Might We? (HMW), Story board, Brainstorming.

**UNITI-V: PROTOTYPING****(6 Periods)**

What is a prototype? - Prototyping as a mindset, prototype examples, prototyping for products; Why we prototype? Fidelity for prototypes, Process of prototyping- Minimum Viable prototype.

**UNIT – V: TESTING PROTOTYPES****(6 Periods)**

Prototyping for digital products: What's unique for digital, Preparation; Prototyping for physical products: What's unique for physical products, Preparation; Testing prototypes with users.

**Total Periods: 30**

*Topics for self-study are provided in the lesson plan*

**TEXT BOOKS:**

1. S. Salivahanan, S. Suresh Kumar, D. Praveen Sam, *Introduction to Design Thinking*, Tata Mc Graw Hill, First Edition, 2019.
2. Kathryn McElroy, *Prototyping for Designers: Developing the best Digital and Physical Products*, O'Reilly, 2017.

**REFERENCE BOOKS:**

1. Michael G. Luchs, Scott Swan , Abbie Griffin, *Design Thinking – New Product Essentials from PDMA*, Wiley, 2015.
2. Vijay Kumar, *101 Design Methods: A Structured Approach for Driving Innovation in Your Organization*, 2012.

**ADDITIONAL LEARNING RESOURCES:**

- <https://www.interaction-design.org/literature/article/5-stages-in-the-design-thinking-process>
- <https://www.ibm.com/design/thinking/page/toolkit>
- <https://www.interaction-design.org/literature/article/define-and-frame-your-design-challenge-by-creating-your-point-of-view-and-ask-how-might-we>
- <https://www.culturepartnership.eu/en/article/ten-tools-for-design-thinking>
- <https://nptel.ac.in/courses/109/104/109104109/>
- <https://nptel.ac.in/courses/110106124/>

**II B. Tech. – II Semester**  
**(19BT31202) SOFTWARE ENGINEERING**  
(Common to CSE and CSSE)

|            |            |             |   |   |   |   |
|------------|------------|-------------|---|---|---|---|
| Int. Marks | Ext. Marks | Total Marks | L | T | P | C |
| 40         | 60         | 100         | 3 | - | - | 3 |

**PRE-REQUISITES:** -

**COURSE DESCRIPTION:** Concepts of software engineering; Software process models; Conventional and agile process models; Software requirements engineering process; System analysis; Architectural design; User interface design and re-engineering; Software testing; Risk and quality management.

**COURSE OUTCOMES:** *After successful completion of the course, students will be able to:*

- CO1. Understand fundamental concepts of software engineering and analyze process models required to develop a software system.
- CO2. Analyze software requirements and model requirements for the given scenario.
- CO3. Apply design concepts and metrics for software development.
- CO4. Apply testing strategies and techniques for quality software.
- CO5. Analyze risks in software development life cycle and apply risk strategies to mitigate risks.

**DETAILED SYLLABUS:**

**UNIT- I: SOFTWARE ENGINEERING AND SOFTWARE PROCESS (11 Periods)**

**A Generic View of Process:** The Nature of software, Software engineering- Software engineering layers; The software process, Software engineering practice, Software myths.

**Process Models:** A generic process model, prescriptive process models-The Waterfall model, Incremental process models, Specialized process models; The unified process, Agile development-agility, Agile process, Extreme programming (XP), Scrum, Dynamic system development method, Agile modeling (AM), Agile unified process (AUP).

**UNIT- II: REQUIREMENTS ENGINEERING AND MODELING (7 Periods)**

**Requirements Engineering:** Functional and non-functional requirements, The software requirements document, Requirements specifications, Requirements engineering processes, Requirements elicitation and analysis, Requirements validation, Requirements management.

**Requirements Modeling:** Requirements analysis, Data modeling concepts, Flow-oriented modeling, Scenario based modeling, UML models that supplement the use case, Case study on requirements modeling for Web and Mobile Apps.

**UNIT- III: DESIGN ENGINEERING AND METRICS (9 Periods)**

**Design using UML:** Design concepts, Software architecture, Architectural styles, Class diagram - Terms and concepts, Use case diagram - Terms and concepts, Activity diagrams - Terms and concepts, Interaction diagrams - Terms and concepts, State

machine diagram- Terms and concepts, Component diagram- Terms and concepts, Deployment diagram- Terms and concepts.

**Process and Project Metrics:** Metrics in the process and project domains, Software measurement, Metrics for software quality.

**UNIT- IV: SOFTWARE TESTING STRATEGIES AND APPLICATIONS (8 Periods)**

**Testing strategies:** A strategic approach to software testing, Strategic issues, Test strategies for conventional software, Test strategies for object oriented software, Validation testing, System testing, The art of debugging.

**Testing Conventional Applications:** Software testing fundamentals, White box testing-Basis path testing, Control structure testing; Black box testing, Object oriented testing methods.

**UNIT- V: RISK, QUALITY MANAGEMENT AND REENGINEERING (10 Periods)**

**Risk and Quality Management:** Reactive and proactive risk strategies, Software risks, Risk Mitigation Monitoring and Management (RMMM), RMMM plan, Formal Technical Reviews (FTR), Software Quality Assurance (SQA)-Tasks, Goals and Metrics; Software reliability.

**Reengineering:** Introduction, Business Process Reengineering (BPR), Software reengineering, Restructuring, Reverse engineering, Forward engineering.

**Total Periods: 45**

***Topics for self-study are provided in the lesson plan***

**TEXT BOOKS:**

1. Roger S. Pressman, *Software Engineering - A Practitioner's Approach*, McGraw-Hill International Edition, Eighth Edition, 2015.
2. Ian Sommerville, *Software Engineering*, Pearson Education, Ninth Edition, 2011.

**REFERENCE BOOKS:**

1. Grady Booch, James Rum Baugh and Ivar Jacobson, *The Unified Modeling Language User Guide*, Second Edition, Pearson Education, 2009.
2. K. K. Aggarwal and Yogesh Singh, *Software Engineering*, New Age International Publishers, Third Edition, 2007.
3. Shely Cashman Rosenblatt, *Systems Analysis and Design*, Thomson Publications, Sixth Edition, 2006.

**ADDITIONAL LEARNING RESOURCES:**

- <https://nptel.ac.in/courses/106105087/>
- <https://nptel.ac.in/courses/106105182/>

**II B. Tech. - II Semester**  
**(19BT40501) COMPUTER NETWORKS**  
(Common to CSE and IT)

| Int. Marks | Ext. Marks | Total Marks | L | T | P | C |
|------------|------------|-------------|---|---|---|---|
| 40         | 60         | 100         | 3 | - | - | 3 |

**PRE-REQUISITES:** A course on "Operating Systems"

**COURSE DESCRIPTION:** Introduction to computer networks; Protocols of physical layer, data link layer, medium access control sub layer, network layer, transport layer, application layer.

**COURSE OUTCOMES:** After successful completion of the course, students will be able to:

- CO1. Analyze the types of network topologies, layers and protocols.
- CO2. Evaluate sub netting and routing algorithms for finding optimal paths in networks.
- CO3. Solve problems related to flow control, error control and congestion control in data transmission.
- CO4. Assess the impact of wired and wireless networks in the context of network protocols Like DNS, SMTP, HTTP, and FTP.
- CO5. Apply ethical principles and standards for developing network-based solutions.

**DETAILED SYLLABUS:**

**UNIT- I: INTRODUCTION AND PHYSICAL LAYER (9 Periods)**

Network hardware, Network software, Reference models - OSI, TCP/IP; Example networks - Internet; Wireless LANs - 802.11.

**Physical Layer** - Guided transmission media, Wireless transmission, Switching - Circuit switching, Packet switching.

**UNIT- II: DATA LINK LAYER AND MEDIUM ACCESS CONTROL SUBLAYER (9 Periods)**

**Data Link Layer:** Data link layer design issues, Error detection and correction - CRC, Hamming codes; Elementary data link protocols, Sliding window protocols.

**Medium Access Control Sub layer:** ALOHA, Carrier sense multiple access protocols, Collision free protocols, Ethernet, Data link layer switching - Repeaters, Hubs, Bridges, Switches, Routers, Gateways.

**UNIT- III: NETWORK LAYER (9 Periods)**

Network layer design issues, Routing algorithms - Shortest path algorithm, Flooding, Distance vector routing, Link state routing, Hierarchical routing, Broadcast routing, Multicast routing, Anycast routing; Congestion control algorithms, Network layer in the internet - The IP version 4 protocol, IP addresses, IP version 6, Internet control protocols, OSPF, BGP.

**UNIT- IV: TRANSPORT LAYER****(9 Periods)**

UDP – Segment header, Remote procedure call, Real-time transport protocols; TCP – service model, Protocol, Segment header, Connection establishment, Connection release, Sliding window, Timer management, Congestion control.

**UNIT- V: APPLICATION LAYER****(9 Periods)**

Domain Name System (DNS) - Name space, Domain resource records, Name servers; Electronic mail - Architecture and services, User agent, Message formats, Message transfer, Final delivery; The World Wide Web - Architectural overview, HTTP, FTP.

**Total Periods: 45**

***Topics for self-study are provided in the lesson plan***

**TEXT BOOK(S):**

1. Andrew S. Tanenbaum and David J. Wetherall, *Computer Networks*, Pearson, 5<sup>th</sup> Edition, 2015.

**REFERENCE BOOKS:**

1. Behrouz A. Forouzan, *Data Communications and Networking*, McGraw Hill, 5<sup>th</sup> Edition, 2013.
2. James F. Kurose and Keith W. Ross, *Computer Networking: A Top-Down Approach*, Pearson, 7<sup>th</sup> Edition, 2017.

**ADDITIONAL LEARNING RESOURCES:**

- <https://www.cisco.com/c/en/us/solutions/small-business/resourcecenter/networking/networking-basics.html>
- <https://memberfiles.freewebs.com/00/88/103568800/documents/Data.And.Computer.Communications.8e.WilliamStallings.pdf>



**II B. Tech. - II Semester**  
**(19BT40502) DATABASE MANAGEMENT SYSTEMS**

(Common to CSE, CSSE and IT)

| Int. Marks | Ext. Marks | Total Marks | L | T | P | C |
|------------|------------|-------------|---|---|---|---|
| 40         | 60         | 100         | 3 | 1 | - | 4 |

**PRE-REQUISITES:** A course on "Data Structures"

**COURSE DESCRIPTION:** Introduction to database systems; Database design; Relational model; Relational algebra; SQL queries; Constraints and triggers; PL/SQL; Schema refinement and normal forms; Transaction management; Concurrency control; Overview of storage and indexing.

**COURSE OUTCOMES:** After successful completion of the course, students will be able to:

- CO1. Apply the concepts of ER-modeling and normalization to design viable data models for a given problem.
- CO2. Formulate relational database schemas, apply suitable integrity constraints, for querying databases.
- CO3. Use SQL to store, query, and manipulate data in relational databases.
- CO4. Develop PL/SQL blocks to centralize database applications for maintainability and reusability.
- CO5. Analyze transaction processing, concurrency control and storage methods for database management.

**DETAILED SYLLABUS:**

**UNIT- I: INTRODUCTION TO DATABASE SYSTEMS AND DATABASE DESIGN**

**(8 Periods)**

**Introduction to Database Systems:** Database system applications, Purpose of database systems, View of data - Data abstraction, Instances and schemas, Data models; Database languages - Data Definition Language, Data Manipulation Language; Database architecture, Database users and administrators.

**Introduction to Database design:** Database design and ER diagrams, Entities, attributes and entity sets, Relationships and relationship sets, Additional features of ER model, Conceptual Design with ER model.

**UNIT- II: RELATIONAL MODEL AND RELATIONAL ALGEBRA**

**(8 Periods)**

**Relational Model:** Creating and modifying relations, Integrity constraints over relations, Enforcing integrity constraints, Querying relational data, Logical database design, Introduction to views, Destroying/altering tables and views.

**Relational Algebra:** Preliminaries, Relational Algebra operators.

**UNIT- III: SQL AND PL/SQL**

**(10 Periods)**

**SQL:** Form of basic SQL query, Nested queries, Aggregate operators, Null values, Complex integrity constraints in SQL, Triggers and active databases.

**PL/SQL:** Generic PL/SQL block, PL/SQL data types, Control structure, Procedures and functions, Cursors, Database triggers.

**UNIT- IV: SCHEMA REFINEMENT AND TRANSACTIONS (10 Periods)**

**Schema Refinement:** Problems caused by redundancy, Decompositions, Problems related to decomposition, Functional dependencies, Reasoning about FDs, First normal form, Second normal form, Third normal form, Boyce-Codd normal form, Multivalued dependencies, Fourth normal form, Join dependencies, Fifth normal form.

**Transactions:** Transaction concept, Transaction atomicity and durability, Concurrent Executions – Serializability, Recoverability, Implementation of isolation, Testing for serializability.

**UNIT- V: CONCURRENCY CONTROL, STORAGE AND INDEXING (9 Periods)**

**Concurrency Control:** Lock Based Protocols, Timestamp Based Protocols, Validation Based Protocols, Multiple Granularity, Deadlock Handling.

**Storage and Indexing:** Data on external storage, File organizations and indexing – Clustered indexes, Primary and secondary indexes; Index data structures – Hash based indexing, Tree based indexing; Comparison of file organizations.

**Total Periods: 45**

**Topics for self-study are provided in the lesson plan**

**TEXT BOOKS:**

1. Raghuram Ramakrishnan, Johannes Gehrke, *Database Management Systems*, McGraw Hill, 3<sup>rd</sup> Edition, 2014.
2. Abraham Silberschatz, Henry F. Korth, S. Sudarshan, *Database System Concepts*, McGraw Hill, 7<sup>th</sup> edition, 2019.

**REFERENCE BOOKS:**

1. Ivan Bayross, *SQL, PL/SQL: The Programming Language of Oracle*, BPB publications, 4<sup>th</sup> Edition, 2017.
2. Ramez Elmasri, Shamkant B. Navathe, *Fundamentals of Database Systems*, 7<sup>th</sup> Edition, Pearson, 2015.

**ADDITIONAL LEARNING RESOURCES:**

- [https://swayam.gov.in/nd1\\_noc19\\_cs46/preview](https://swayam.gov.in/nd1_noc19_cs46/preview)
  - <https://www.classcentral.com/course/swayam-introduction-to-database-systems-17660>

## II B. Tech. - II Semester

### (19BT40503) DESIGN AND ANALYSIS OF ALGORITHMS

(Common to CSE and CSSE)

| Int. Marks | Ext. Marks | Total Marks | L | T | P | C |
|------------|------------|-------------|---|---|---|---|
| 40         | 60         | 100         | 3 | - | - | 3 |

**PRE-REQUISITES:** A course on "Data Structures"

**COURSE DESCRIPTION:** Algorithms and asymptotic notations; Algorithm performance analysis; Amortized analysis; Recurrences; Disjoint sets; Divide and Conquer; Dynamic programming; Greedy algorithms; Back tracking; Branch and bound; NP-hard and NP-complete problems.

**COURSE OUTCOMES:** After successful completion of the course, students will be able to:

- CO1. Analyze the complexity of algorithms by applying the knowledge of asymptotic notations and recurrence methods.
- CO2. Analyze the given problem and identify appropriate algorithm design technique for problem solving.
- CO3. Perceive and apply different algorithm design paradigms to find solutions for computing problems.
- CO4. Apply the knowledge of NP-hard and NP-Complete complexity classes to classify decision problems.

#### DETAILED SYLLABUS:

##### UNIT- I: INTRODUCTION TO ALGORITHMS (10 Periods)

Algorithm, Algorithm pseudocode conventions, Performance analysis - Space complexity, Time complexity, Asymptotic notations; Amortized analysis – Aggregate analysis, Accounting method, Potential method; Recurrences - Substitution method, Recursion-tree method, Master method.

##### UNIT- II: DISJOINT SETS, DIVIDE AND CONQUER (8 Periods)

**Disjoint Sets:** Operations, Union and Find algorithms.

**Divide and Conquer:** General method, Defective chess board, Binary search, Finding maximum and minimum, Merge sort, Strassen's matrix multiplication.

##### UNIT- III: DYNAMIC PROGRAMMING (9 Periods)

General method, Matrix-chain multiplication, All pairs shortest path, Optimal binary search trees, 0/1 Knapsack problem, Traveling salesperson problem, Flow shop scheduling.

##### UNIT- IV: GREEDY METHOD, BACKTRACKING (10 Periods)

**Greedy Method:** General method, Knapsack problem, Job sequencing with deadlines, Huffman codes, Single source shortest paths, Optimal merge patterns.

**Backtracking:** General method, 8-Queens problem, Sum of subsets, Graph coloring, Hamiltonian cycles.

## **UNIT- V: BRANCH AND BOUND, NP-HARD AND NP-COMPLETE PROBLEMS**

**(8 Periods)**

**Branch and Bound:** LC search, LC branch and bound, FIFO branch and bound, 0/1 knapsack problem, Traveling salesperson problem.

**NP Hard And NP-Complete Problems:** Nondeterministic algorithms, NP-hard and NP-complete classes, Cook's theorem, NP-hard scheduling problems – Scheduling identical processors.

**Total Periods: 45**

***Topics for self-study are provided in the lesson plan***

### **TEXT BOOKS:**

1. Ellis Horowitz, Sartaj Sahni, and Sanguthevar Rajasekaran, *Fundamentals of Computer Algorithms*, 2<sup>nd</sup> Edition, Universities Press, 2008.
2. Thomas H. Cormen, Charles E. Leiserson, Ronald L. Rivest, Clifford Stein, *Introduction to Algorithms*, 3<sup>rd</sup> Edition, MIT Press, 2009.

### **REFERENCE BOOKS:**

1. Michael T. Goodrich and Roberto Tamassia, *Algorithm Design and Applications*, Wiley, 2014.
2. Alfred V. Aho, John E. Hopcroft and Jeffrey D. Ullman, *The Design and Analysis of Computer Algorithms*, Pearson, 2006.

### **ADDITIONAL LEARNING RESOURCES:**

- <https://nptel.ac.in/courses/106/106/106106131/>

**II B. Tech. – II Semester**  
**(19BT4HS01) BANKING AND INSURANCE**

(Open Elective-2)  
(Common to CE, ME, CSE, CSSE and IT)

| Int. Marks | Ext. Marks | Total Marks | L | T | P | C |
|------------|------------|-------------|---|---|---|---|
| 40         | 60         | 100         | 3 | - | - | 3 |

**PRE-REQUISITES: -**

**COURSE DESCRIPTION:** Scope, Objectives and Elements of cost Accounting; Cost Sheet and Tender quotations; Variance Analysis: Material variances, Labor variances; Meaning and Scope, Liquidity, Profitability Ratios: concept of Risk and Return on Investment.

**COURSE OUTCOMES:** After successful completion of the course, students will be able to:

CO1. Demonstrate knowledge in concepts and functions of Banking and Insurance, RBI, bank and customer relationship, types of accounts, types of loans and advances, types of insurance and risk.

CO2. Develop skills to provide solutions in electronic payment system, business models and insurance claims.

**DETAILED SYLLABUS:**

**UNIT- I: INTRODUCTION TO BANKING (9 Periods)**

Meaning - Importance of banking - Functions of banking - **Reserve Bank of India:** Functions – Role of RBI in sustainable development.

**UNIT- II: BANK-CUSTOMER RELATIONSHIP (9 Periods)**

Debtor-creditor relationship, deposit products or services, payment and collection of cheques. Accounts – Types of accounts, procedure for opening and closing an account - Loans and Advances- Principles of lending and types of loans.

**UNIT- III: ELECTRONIC PAYMENT SYSTEM & BUSINESS MODELS (9 Periods)**

Introduction to Online Banking - types of e-payment system, e-cash, NEFT, RTGS, Credit cards, Debit cards and Electronic Wallet - Business models: B2B, B2C, C2C and B2G.

**UNIT- IV:INTRODUCTION TO RISK AND INSURANCE (9 Periods)**

Concept of risk, risk Vs uncertainty. **Insurance:** Definition, Insurance as risk mitigation mechanism, elements of insurance.

**UNIT- V: INSURANCE OVERVIEW (9 Periods)**

Principles and Functions of Insurance - Types of Insurance - LIC and GIC - IRDA - Insurance Players in India.

**Total Periods: 45**

**Topics for self-study are provided in the lesson plan**

**TEXT BOOKS:**

1. RanganadhaChary,A.V. and Paul, R.R., *Banking and Financial system*, Kalyani Publisher, New Delhi, 3<sup>rd</sup> edition, 2016.
2. Sharma,R.K., Shashi K. Gupta and Jagwant Singh, *Banking and Insurance*, Kalyani Publishers, New Delhi, 17<sup>th</sup> edition, 2014.

**REFERENCES BOOKS:**

1. *Indian Institute of Banking & Finance, Digital Banking*, Taxmann Publications Pvt. Ltd., 2016
2. Jyotsna Sethi and Nishwan Bhatia, *Elements of Banking and Insurance*, PHI Learning Pvt. Ltd., 2<sup>nd</sup> edition, 2012.

## II B. Tech. – II Semester

### (19BT4HS03) COST ACCOUNTING AND FINANCIAL MANAGEMENT

(Open Elective-2)

(Common to CE, ME, CSE, CSSE and IT)

| Int. Marks | Ext. Marks | Total Marks | L | T | P | C |
|------------|------------|-------------|---|---|---|---|
| 40         | 60         | 100         | 3 | - | - | 3 |

#### PRE-REQUISITES: -

**COURSE DESCRIPTION:** Scope, Objectives and Elements of cost Accounting; Cost Sheet and Tender quotations; Variance Analysis: Material variances, Labor variances; Meaning and Scope, Liquidity, Profitability Ratios: concept of Risk and Return on Investment.

**COURSE OUTCOMES:** After successful completion of the course, students will be able to:

CO1. Demonstrate knowledge in Costing, Material, Labor, Overheads, Cost control, risk and return, security analysis and portfolio management.

CO2. Design solutions for effective investment decisions, cost analysis, tenders, quotations, variance analysis, ratio analysis and capital budgeting techniques.

#### DETAILED SYLLABUS:

##### UNIT- I: COST ACCOUNTING

(9 Periods)

Meaning of Cost and Cost Accounting, Objectives, Scope, Advantages and disadvantages – Cost Accounting Vs Management Accounting – Elements of Costing – Installation of costing system – Material Control, Labour Control, Overhead Control.

##### UNIT- II: COST SHEET & PREPARATION OF COST SHEET

(9 Periods)

Analysis of Cost – Importance of Costing while pricing the products - Preparation of cost sheet, estimate, tender and quotation (Simple problems).

##### UNIT- III: STANDARD COSTING & VARIANCE ANALYSIS

(9 Periods)

Introduction to Standard Costing & Variances – Variance Analysis: Material variances, Labour variances (Simple Problems).

##### UNIT- IV: FINANCIAL MANAGEMENT & RATIO ANALYSIS

(9 Periods)

Meaning, Objectives - Nature and Scope, Importance of FM – **Ratio Analysis:** Solvency ratios, Liquidity ratios, Profitability ratios, Financial Statement Analysis through ratios (Simple Problems).

##### UNIT- V: INTRODUCTION TO INVESTMENT

(9 Periods)

Investment – Meaning and Definition- concept of risk and returns-Investment Alternatives- Capital Budgeting techniques – Security Analysis and Portfolio Management (Basic concepts).

**Total Periods: 45**

**Topics for self-study are provided in the lesson plan**

**TEXT BOOKS:**

1. S.P. Jain and K.L. Narang: *Cost Accounting*, Kalyani Publishers, Ludhiana, 10<sup>th</sup> edition, 2016.
2. I.M. Pandey, *Financial Management*, Vikas Publishing House Pvt. Ltd., 14<sup>th</sup> edition, 2016.

**REFERENCE BOOKS:**

1. The Institute of Company Secretaries of India, *Cost and Management Study Material*, New Delhi.
2. CA SaravanaPrasath, *Cost Accounting and Financial management*, Wolters Kluwer India Pvt. Ltd., New Delhi, 2018 edition, 2018.



## II B. Tech. - II Semester

### (19BT4HS05) GENDER AND ENVIRONMENT

(Open Elective-2)

(Common to CE, ME, CSE, CSSE and IT)

| Int. Marks | Ext. Marks | Total Marks | L | T | P | C |
|------------|------------|-------------|---|---|---|---|
| 40         | 60         | 100         | 3 | - | - | 3 |

#### PRE-REQUISITES: --

**COURSE DESCRIPTION:** Gender and the environment relationship, Gendered Roles in the family & community, Gender and sustainable development, Gender in environmental justice, Gender & environmental security.

**COURSE OUTCOMES:** After successful completion of the course, students will be able to:

**CO1.** Apply the knowledge of gender & environment connections, key issues and topics within global environmental politics in environmental decision-making.

**CO2.** Comprehend the concepts of gender and sustainable development through debates, and policy documents.

**CO3.** Analyze the concept of environmental security and justice by identifying the sources of insecurity.

#### DETAILED SYLLABUS:

##### UNIT- I: GENDER AND ENVIRONMENT RELATIONSHIP (9 Periods)

Introduction–Gender and Environment–Development of gender roles–Society, gender & environment – Understanding environmental politics – Gender-environment connections–Eco-feminism - Cultural eco-feminism–Social eco-feminism - Feminist political ecology.

##### UNIT- II: GENDERED ROLES IN THE FAMILY & COMMUNITY (9 Periods)

Organization of the household – Domestic division of labour - Food: growing, harvesting, shopping, preparing, and cooking.

Gender & Power- Planning – Politics – NGO – Gendering of environmental protest – Environmental decision-making.

##### UNIT- III: GENDER AND SUSTAINABLE DEVELOPMENT (9 Periods)

Concept of sustainability & its achievement – Concept of sustainable development – Ecological Modernization – Gender & sustainability debates – Gender & sustainable development debates - Gender in policy documents – Gender, poverty & equity in sustainable development.

##### UNIT- IV: GENDER IN ENVIRONMENTAL JUSTICE (9 Periods)

Normative Concerns ( Fairness, Inequality & Justice) - Making sense of Environmental justice – Ecological debt, Transnational harm, & human rights – Ecological justice – Gender & Environmental Justice – Gender, Vulnerability & risk – Women in environmental justice movements – Knowledge & participation – Gender, sustainability & justice as guiding concepts.

**UNIT-V: GENDER AND ENVIRONMENTAL SECURITY****(9 Periods)**

Connections between security & the environment – **Gender, environment & security:** Sustainability as security - poverty & insecurity – Insecurity as injustice – Competing ways of thinking security – Reflecting on sources of insecurity – **Case Study** – Food Security -**Case Study** – The impacts of natural disasters.

**Total Periods: 45**

**Topics for self-study are provided in the lesson plan**

**TEXT BOOKS:**

1. Nicole Detraz, *Gender and the Environment*, Polity Press, Cambridge, UK, 2017.
2. Susan Buckingham- Hatfield, *Gender and Environment*, Routledge, London, 2000.

**REFERENCE BOOKS:**

1. Promillakapur (ed). (2000). "Empowering Indian Women" Publication Division, Government of India, New Delhi.
2. Ronnie Vernooy, (Ed). (2006). "Social and gender Analysis Natural Resource Management: Learning studies and lessons from Aisa" Sage, New Delhi.
3. Swarup, Hemlata and Rajput, Pam. (2000). *Gender Dimensions of Environmental and Development Debate: The Indian Experience*" In SturatS. Nagel, (ed). "India"s Development and Public Policy", Ashgate, Burlington.

**II B. Tech. – II Semester**  
**(19BT4HS07) INDIAN ECONOMY**  
(Open Elective-2)  
(Common to CE, ME, CSE, CSSE and IT)

|            |            |             |   |   |   |   |
|------------|------------|-------------|---|---|---|---|
| Int. Marks | Ext. Marks | Total Marks | L | T | P | C |
| 40         | 60         | 100         | 3 | - | - | 3 |

**PRE-REQUISITES: -**

**COURSE DESCRIPTION:** Introduction; Time Value of Money; Elementary Economic Analysis; Value Analysis/Value Engineering; Economic Planning.

**COURSE OUTCOMES:** *After successful completion of the course, students will be able to:*

**CO1.** Understand the basic concepts of economics, economic analysis, economic planning and strate.

**CO2.** Demonstrate knowledge in capital budgeting, evaluation of engineering projects, depreciation policy and familiarize with the concepts of value analysis vs value engineering.

**DETAILED SYLLABUS:**

**UNIT- I: INTRODUCTION**

**(9 Periods)**

Economics - Flow in an Economy, Law of Supply and Demand; Micro and Macro Economics; Relationship between Science, Engineering, Technology and Economic Development; Concept of Engineering Economics-Types of Efficiency, Definition and Scope of Engineering Economics.

**UNIT- II: ELEMENTARY ECONOMIC ANALYSIS**

**(9 Periods)**

Economic Analysis – Meaning, Significance, Simple Economic Analysis; Material Selection for a Product, Substitution of Raw Material; Design Selection for a Product; Material Selection-Process Planning, Process Modification.

**UNIT- III: ECONOMIC PLANNING**

**(9 Periods)**

Introduction - Need For Planning in India, Five year plans(1951-2012), NITI Aayog (from 2014 onwards); Inclusive Growth-Meaning, Significance, Need for inclusive growth in India, Strategy for more inclusive growth, Challenges and Prospects; Employment and Inclusive Growth in India, Role of engineers in sustaining inclusive growth.

**UNIT- IV: TIME VALUE OF MONEY**

**(12 Periods)**

Concepts and Application; Capital Budgeting-Traditional and Modern Methods; Simple and Compound Interest, Cash Flow Diagram, Principle of Economic Equivalence; Evaluation of Engineering Projects – Present Worth Method, Future Worth Method, Annual Worth Method, Internal Rate of Return Method, Cost-benefit Analysis in Public Projects; Depreciation Policy-Depreciation of Capital Assets, Causes of Depreciation, Straight Line Method and Declining Balance Method.

**UNIT- V: VALUE ANALYSIS/VALUE ENGINEERING****(6 Periods)**

Introduction - Value Analysis, Value Engineering, Functions, Aims; Value Analysis vs Value Engineering; Value Engineering Procedure- Advantages, Application Areas.

**Total Periods: 45**

*Topics for self-study are provided in the lesson plan*

**TEXT BOOKS:**

1. Panneerselvam. R., *Engineering Economics*, PHI Learning Private Limited, New Delhi, 2nd edition, 2013.
2. Jain. T. R., V. K. Ohri, O. P. Khanna. *Economics for Engineers*. VK Publication, 1st edition, 2015.

**REFERENCE BOOKS:**

1. DuttRudar and Sundhram K. P. M., *Indian Economy*, S. Chand, New Delhi, 62<sup>nd</sup> revised edition, 2010.
2. Misra. S. K. and V. K. Puri., *Indian Economy: Its Development Experience*, Himalaya Publishing House, Mumbai, 32<sup>nd</sup> edition, 2010.

## II B. Tech. – II Semester

### (19BT4HS09) LIFE SKILLS

(Open Elective-2)

(Common to CE, ME, CSE, CSSE and IT)

| Int. Marks | Ext. Marks | Total Marks | L | T | P | C |
|------------|------------|-------------|---|---|---|---|
| 40         | 60         | 100         | 3 | - | - | 3 |

#### PRE-REQUISITES: -

**COURSE DESCRIPTION:** Positive attitude; Self-discovery-Interpersonal relationships; Cross-cultural communication; Core thinking-Problem solving and Decision making; Business presentations and Public speaking.

**COURSE OUTCOMES:** After successful completion of the course, students will be able to:

- CO1. Gain knowledge in strategies involved in developing positive attitude, process of knowing oneself and managing effective interpersonal relationships.
- CO2. Analyse problem solving strategies in Decision Making and SWOT analysis.
- CO3. Communicate effectively with Engineering Community and Society by demonstrating presentation skills in professional arena.

#### DETAILED SYLLABUS:

##### UNIT- I: POSITIVE ATTITUDE (9 Periods)

Introduction, Features of attitudes, Formation of attitudes, Ways of changing attitude in a person, Attitude in a work place, Developing positive attitude, Obstacles in developing positive attitude, Measuring attitude.

##### UNIT- II: SELF DISCOVERY AND INTERPERSONAL RELATIONSHIPS (9 Periods)

Importance of knowing yourself, Process of knowing yourself, SWOT Analysis, Elements of attitude in interpersonal relationships, Methods to deal with different types of interpersonal relationship skills.

##### UNIT- III: CROSS-CULTURAL COMMUNICATION (9 Periods)

Different Communication Styles, Cultural variables, communication sensitivity and variables of national culture, Individual Cultural Variables, Cross-cultural Communication Strategies, Potential hot spots in cross-cultural communication, Cross-cultural communication – Basic Tips.

##### UNIT- IV: CORE THINKING, PROBLEM SOLVING AND DECISION MAKING

(9 Periods)

Process of developing core thinking skills, Categories of thinking: Critical & Creative, Understanding problem solving, Cause of problems, Stages of problem solving, Methods of problem solving, Types of decision making.

**UNIT- V: BUSINESS PRESENTATIONS AND PUBLIC SPEAKING (9 Periods)**

Business presentations and speeches, structuring the material, Types of delivery, Guidelines for delivery, Effective sales presentation, Controlling nervousness and stage fright.

**Total Periods: 45**

***Topics for self-study are provided in the lesson plan***

**TEXT BOOKS:**

1. Dr. K. Alex (2018) *Soft Skills*, S. Chand and Company Limited, New Delhi.
2. Manmohan Joshi (2017) *Soft Skills*, bookboon.com, Bangalore.

**REFERENCE BOOKS:**

1. Meenakshi Raman and Prakash Singh (2013), *Business Communication*, Oxford University Press, New Delhi.
2. Jeff Butterfield (2011) *Soft Skills for Everyone*, Cengage Learning India Private Limited, Delhi.

## II B. Tech. – II Semester

### (19BT4HS11) PROFESSIONAL ETHICS

(Open Elective-2)

(Common to CE, ME, CSE, CSSE and IT)

| Int. Marks | Ext. Marks | Total Marks | L | T | P | C |
|------------|------------|-------------|---|---|---|---|
| 40         | 60         | 100         | 3 | - | - | 3 |

#### PRE-REQUISITES: -

**COURSE DESCRIPTION:** Engineering Ethics; Professional Ideals and Virtues; Engineering as Social Experimentation; Responsibilities and Rights; Global Issues.

**COURSE OUTCOMES:** After successful completion of the course, students will be able to:

CO1. Demonstrate knowledge in Engineering Ethics, Responsibilities and Rights.

CO2. Analyze the concepts of Engineering in Social Experimentation and Global Issues.

CO3. Apply the reasoning informed by the various aspects professional Ethics and its provisions to assess societal issues and the consequent responsibilities relevant to the Professional engineering practice.

#### DETAILED SYLLABUS:

##### UNIT –I: ENGINEERING ETHICS

(9 Periods)

Scope and aim of engineering ethics, Senses of engineering ethics, Variety of moral issues, Types of inquiry, Moral dilemmas, Moral autonomy-Kohlberg's theory, Gilligan's theory, Consensus and controversy.

##### UNIT-II: PROFESSIONAL IDEALS AND VIRTUES

(8 Periods)

Theories about virtues, Professions, Professionalism, Characteristics, Expectations, Professional responsibility, Integrity, Self-respect, Sense of responsibility, Self-interest, Customs and religion, Self-interest and ethical egoism, Customs and ethical relativism, Religion and divine command ethics, Use of ethical theories, Resolving moral dilemmas and moral leadership.

##### UNIT- III: ENGINEERING AS SOCIAL EXPERIMENTATION

(10 Periods)

Engineering as experimentation, Similarities to standard experiments, Learning from the past and knowledge gained, Engineers as responsible experimenters, Conscientiousness, Moral autonomy and accountability, The challenger case, Codes of ethics and limitations, Industrial standards, Problems with the law of engineering.

##### UNIT- IV: RESPONSIBILITIES AND RIGHTS

(9 Periods)

Collegiality and loyalty, Respect for authority, Collective bargaining, Confidentiality, Conflict of interests, Occupational crime, Rights of engineers, Professional rights, Whistle-blowing, The BART case, Employee rights and discrimination.

**UNIT-V: GLOBAL ISSUES****(9 Periods)**

Multinational corporations, Professional ethics, Environmental ethics, Computer ethics, Engineers as consultants, Witnesses, Advisors and Leaders, Engineers as Managers, Managerial ethics applied to Engineering Profession, moral leadership.

**Total Periods: 45**

*Topics for self-study are provided in the lesson plan*

**TEXT BOOKS:**

1. Mike W. Martin and Roland Schinzinger, *Ethics in Engineering*, Tata McGraw-Hill, 3<sup>rd</sup> edition, 2007.
2. Govindarajan, M., Nata Govindarajan, M., Natarajan, S. and Senthil kumar, V. S., *Engineering Ethics*, Prentice Hall of India, 2004.

**REFERENCE BOOKS:**

1. S. Kannan and K. Srilakshmi, *Human Values and Professional Ethics*, Taxmann Allied Services Pvt Ltd., 2009.
2. Edmund G. Seebauer and Robert L. Barry, *Fundamental of Ethics for Scientists and Engineers*, Oxford University Press, 2001.



## II B. Tech. – II Semester

### (19BT4HS13) INDIAN TRADITION AND CULTURE

(Open Elective-2)

(Common to CE, ME, CSE, CSSE and IT)

| Int. Marks | Ext. Marks | Total Marks | L | T | P | C |
|------------|------------|-------------|---|---|---|---|
| 40         | 60         | 100         | 3 | - | - | 3 |

#### PRE-REQUISITES: -

**COURSE DESCRIPTION:** Basic traits of Indian Culture; Humanistic Reforms under Jainism and Buddhism; Culture in the medieval period; Socio Religious reforms in Indian Culture; Reform movements for harmonious relations.

**COURSE OUTCOMES:** After successful completion of the course, students will be able to:

CO1. Demonstrate the knowledge in Vedic culture, cultural aspects of Buddhism, Jainism and cultural conditions in the medieval period.

CO2. Understand the impact of socio religious reforms and movements on Indian tradition and culture to improve harmonious relations within society.

#### DETAILED SYLLABUS:

##### UNIT- I: BASIC TRAITS OF INDIAN CULTURE (9 Periods)

Meaning and definition and various interpretations of culture, Culture and its features. The Vedic and Upanishadic culture and society. Human aspirations and values in these societies. Chaturvidha purushardhas, Chaturashrma and Chaturvarna theory.

##### UNIT- II: HUMANISTIC REFORMS UNDER JAINISM AND BUDDHISM (9 Periods)

Salient features of Jainism - contributions of Jainism to Indian culture. Contributions of Achaarya and Mahaapragya. Buddhism as a humanistic culture. The four noble truths of Buddhism. Contributions of Buddhism to Indian culture.

##### UNIT- III: CULTURE IN THE MEDIEVAL PERIOD (9 Periods)

Unifications of India under Mouryas and Guptas and their cultural achievements. Cultural conditions under satavahanas. Contributions to pallavas and cholas to art and cultural achievements of vijayanagara rulers.

##### UNIT- IV: SOCIO RELIGIOUS REFORMS IN INDIAN CULTURE (9 Periods)

Western impact on India, Introduction of western education, social and cultural awakening and social reform movements of Rajaramohan Roy - Dayanandha Saraswathi- Anne Besant (theosophical society).

##### UNIT- V: REFORM MOVEMENTS FOR HARMONIOUS RELATIONS (9 Periods)

Vivekananda, Eswarchandravidyasagar and Veeresalingam - emancipation of women and struggle against caste. Rise of Indian nationalism. Mahatma Gandhi- Nonviolence and satyagraha and eradication of untouchability.

**Total Periods: 45**

**Topics for self-study are provided in the lesson plan**

**TEXT BOOK(S):**

1. Valluru Prabhakaraiah, *Indian Heritage and Culture*, Neelkamal Publications Pvt. Ltd. Delhi, First Edition, 2015.

**REFERENCE BOOKS:**

1. L. P. Sharma, *History of Ancient India*, Konark Publishers, Pvt. Ltd. New Delhi, 2010.
2. L. P. Sharma, *History of Medieval India*, Konark Publishers, Pvt. Ltd. New Delhi, 2010.
3. L. P. Sharma, *History of Modern India*, Konark Publishers, Pvt. Ltd. New Delhi, 2010.
4. The Cultural Heritage of India Vol-I, II, III, IV, V, The Ramakrishna Mission Institute of Culture, Calcutta.

## II B. Tech. - II Semester

### (19BT40106) **DISASTER MITIGATION AND MANAGEMENT**

(Open Elective-2)

(Common to CE, ME, CSE, CSSE and IT)

| Int. Marks | Ext. Marks | Total Marks | L | T | P | C |
|------------|------------|-------------|---|---|---|---|
| 40         | 60         | 100         | 3 | - | - | 3 |

**PRE-REQUISITES:** --

**COURSE DESCRIPTION:** Disasters; Earthquakes; Floods; Cyclones; Droughts; Landslides; Disaster management.

**COURSE OUTCOMES:** *After successful completion of the course, students will be able to:*

- CO1. Analyze the vulnerability of an area to natural and man-made disasters/hazards as per the guidelines to solve complex problems using appropriate techniques ensuring safety, environment and sustainability.
- CO2. Propose appropriate mitigation strategies for earthquake and tsunami impacts as per code of practice using suitable techniques ensuring safety, environment and sustainability besides communicating effectively in graphical form.
- CO3. Analyze the causes and impacts of floods, cyclones and droughts using appropriate tools and techniques and suggest mitigation measures ensuring safety, environment and sustainability besides communicating effectively in graphical form.
- CO4. Analyze the causes and impacts of landslides using appropriate tools and techniques and suggest mitigation measures ensuring safety, environment and sustainability.
- CO5. Design disaster management strategies to solve pre, during and post disaster problems using appropriate tools and techniques following the relevant guidelines and latest developments ensuring safety, environment and sustainability besides communicating effectively in graphical form.

#### **DETAILED SYLLABUS:**

##### **UNIT- I: DISASTERS**

**(9 Periods)**

Types of disasters - Natural disasters; Impact of disasters on environment, infrastructure and development; Concepts of hazards and vulnerability analysis, Hazard Assessment, Guidelines for hazard assessment and vulnerability analysis, Basic principles and elements of disaster mitigation.

##### **UNIT- II: EARTHQUAKES**

**(9 Periods)**

Introduction to earthquake, Intensity scale (MSK-64), Seismic zones and activity in India, Action plan for earthquake disaster preparedness, Elements at risk, Recovery and rehabilitation after earthquake, Concepts of Earthquake resistant design and construction of buildings; Tsunami - Onset, Types and causes, Warning, Elements at risk, Typical effects, Specific preparedness and mitigation strategies, Case studies.

**UNIT –III: FLOODS, CYCLONES AND DROUGHTS (11 Periods)**

**Floods and Cyclones:** Onset, Types, Causes, Warnings, Elements at risk, Typical effects, Indian floods and cyclones, Hazard zones, Potential for reducing hazards, Mitigation strategies and community based mitigation, Case studies.

**Droughts:** Onset, Types and warning; Causes, Impact, Early warning and response mechanisms, Mitigation strategies, Droughts in India, Case studies.

**UNIT –IV: LANDSLIDES (8 Periods)**

Onset, Types and warning; Causes, Elements at risk, Indian landslides, Hazards zones, Typical effects, Mitigation strategies and community based mitigation, Case studies.

**UNIT- V: DISASTER MANAGEMENT (8 Periods)**

Disaster management organization and methodology, Disaster management cycle, Disaster management in India – Typical cases and Cost–benefit analysis, Disaster management programs implemented by NGOs and Government of India, Usage of GIS and Remote sensing techniques in disaster management, Leadership and Coordination in Disaster management, Emerging trends in disaster management.

**Total Periods: 45**

***Topics for self-study are provided in the lesson plan***

**TEXT BOOKS:**

1. V. K. Sharma, *Disaster Management*, Medtech Publishing, 2<sup>nd</sup> Edition, 2013.
2. Anand S. Arya, Anup Karanth, and Ankush Agarwal, *Hazards, Disasters and Your Community: A Primer for Parliamentarians*, GOI–UNDP Disaster Risk Management Programme, Government of India, National Disaster Management Division, Ministry of Home Affairs, New Delhi, Version 1.0, 2005.

**REFERENCE BOOKS:**

1. Donald Hyndman and David Hyndman, *Natural Hazards and Disasters*, Cengage Learning, 3<sup>rd</sup> Edition, 2011.
2. *Disaster Management in India*, A Status Report, Ministry of Home Affairs, Govt. of India, May 2011.
3. Rajendra Kumar Bhandari, *Disaster Education and Management: A Joyride for Students, Teachers, and Disaster Managers*, Springer India, 2014.
4. R. B. Singh, *Natural Hazards and Disaster Management*, Rawat Publications, 2009.

**ADDITIONAL LEARNING RESOURCES:**

1. Tushar Bhattacharya, *Disaster Science and Management*, McGraw Hill, 2014.

## II B. Tech. - II Semester

### (19BT40107) SUSTAINABLE ENGINEERING

(Open Elective-2)

(Common to CE, ME, CSE, CSSE and IT)

| Int. Marks | Ext. Marks | Total Marks | L | T | P | C |
|------------|------------|-------------|---|---|---|---|
| 40         | 60         | 100         | 3 | - | - | 3 |

**PRE-REQUISITES:** --

**COURSE DESCRIPTION:** Principles of sustainability; Sustainability metrics and assessment tools; Sustainable engineering practices; Sustainable engineering applications; Sustainable urbanization and industrialization.

**COURSE OUTCOMES:** After successful completion of the course, students will be able to:

- CO1. Analyze the principles of sustainability to solve complex environmental problems following relevant standards/protocols considering society, health, safety and environment.
- CO2. Analyze sustainability metrics and assessment tools to solve complex environmental problems following relevant standards and emerging trends considering society, health, safety, environment and economics besides communicating effectively in graphical form.
- CO3. Analyze sustainable engineering practices to solve complex environmental problems using appropriate tools and techniques following relevant standards considering society, health, safety, environment, economics and management besides communicating effectively in graphical form.
- CO4. Design sustainable engineering applications to solve complex environmental problems using appropriate tools and techniques following relevant standards considering society, health, safety, environment, economics and management besides communicating effectively in graphical form.
- CO5. Analyze sustainable urbanization and industrialization principles to solve complex environmental problems using appropriate tools and techniques following relevant standards considering society, health, safety, environment, economics and management besides communicating effectively in graphical form.

**DETAILED SYLLABUS:**

#### **UNIT- I: PRINCIPLES OF SUSTAINABILITY (9 Periods)**

Emerging challenges, Sustainability and sustainable engineering; Environmental concerns; Social, economic and legal issues; Availability and depletion of natural resources, Disaster resiliency; Multilateral environmental agreements – Basel convention, Clean development mechanism (CDM), Montreal and Kyoto protocols.

#### **UNIT- II: SUSTAINABILITY METRICS AND ASSESSMENT TOOLS (9 Periods)**

Sustainability indicators, metrics and assessment tools, Material flow analysis and material budget, Carbon footprint analysis, Life cycle assessment, Streamlined life-cycle assessment (SLCA), Economic input output-life cycle analysis, Environmental health risk assessment, Other emerging assessment tools.

**UNIT- III: SUSTAINABLE ENGINEERING PRACTICES (9 Periods)**

Sustainable energy engineering, Sustainable waste management, Green and sustainable buildings and infrastructure, Sustainable civil infrastructure, Sustainable remediation of contaminated sites, Climate geoengineering.

**UNIT- IV: SUSTAINABLE ENGINEERING APPLICATIONS (9 Periods)**

Environmental and chemical engineering projects, Materials engineering projects, Infrastructure engineering projects – Background, Methodology, Goal and Scope, Study area, Technical design, Environmental sustainability, Life cycle assessment, Economic sustainability, Social sustainability, Rating systems – ENVISION, LEED, GRIHA, IGBC; Conclusions.

**UNIT- V: SUSTAINABLE URBANIZATION AND INDUSTRIALIZATION (9 Periods)**

Sustainable urbanization and industrialization, United Nations sustainable development goals – Right to education, Poverty eradication, Social and technological changes; Industrial Processes - Material selection, Energy efficiency, Pollution prevention and control techniques, Industrial Ecology, Industrial symbiosis.

**Total Periods: 45**

**Topics for self-study are provided in the lesson plan**

**TEXT BOOKS:**

1. Reddy, K.R., Comeselle, C., and Adams, J.A., *Sustainable Engineering: Drivers, Metrics, Tools, and Applications*, John Wiley & Sons, Inc., Hoboken, New Jersey, 2019, 544p (ISBN: 978-1-119-49393-8).
2. Allen, D. T. and Shonnard, D. R., *Sustainability Engineering: Concepts, Design and Case Studies*, Pearson Education, 1<sup>st</sup> Edition, 2012.

**REFERENCE BOOKS:**

1. Bradley. A.S; Adebayo, A.O., Maria, P., *Engineering Applications in Sustainable Design and Development*, Cengage Learning, 1<sup>st</sup> Edition, 2016.
2. Purohit, S. S., *Green Technology: An Approach for Sustainable Environment*, Agrobios Publication, 1<sup>st</sup> Edition, 2016.
3. *Energy Conservation Building Code (ECBC) 2007*, Bureau of Energy Efficiency, Govt. of India, New Delhi.
4. Twidell, J. W. and Weir, A. D., *Renewable Energy Resources*, Routledge, Taylor & Francis Group, 3<sup>rd</sup> Edition, 2015.

**ADDITIONAL LEARNING RESOURCES:**

1. Daniel A. Vallero and Chris Brasier, *Sustainable Design: The Science of Sustainability and Green Engineering*, Wiley-Blackwell, 1<sup>st</sup> Edition, 2008.
2. Jorge A. Vanegas, *Sustainable Engineering Practice: An Introduction*, Committee on Sustainability, American Society of Civil Engineers, <https://doi.org/10.1061/9780784407509>, 2004.
3. Mackenthun, K.M., *Basic Concepts in Environmental Management*, CRC Press, Taylor & Francis Group, 1<sup>st</sup> Edition, 1999.
4. *Environment Impact Assessment Guidelines*, Notification of Government of India, 2006.

## II B. Tech. - II Semester

### (19BT40108) CONTRACT LAWS AND REGULATIONS

(Open Elective-2)

(Common to CE, ME, CSE, CSSE and IT)

| Int. Marks | Ext. Marks | Total Marks | L | T | P | C |
|------------|------------|-------------|---|---|---|---|
| 40         | 60         | 100         | 3 | - | - | 3 |

#### PRE-REQUISITES: -

**COURSE DESCRIPTION:** Construction contracts; Tenders; Arbitration; Legal requirements; Labour regulations.

**COURSE OUTCOMES:** After successful completion of the course, students will be able to:

**CO1.** Develop construction contracts to solve complex contract related problems by following laws and regulations considering project schedule, cost, quality and risk.

**CO2.** Prepare tenders as per the specifications by following latest developments, laws and regulations to solve complex tender problems considering project schedule, cost, quality and risk.

**CO3.** Analyze arbitration problems to address the contract disputes following the laws and regulations in the context of society.

**CO4.** Analyze legal issues pertaining to contracts and tenders considering society.

**CO5.** Analyze labour regulations to address labour safety issues.

#### DETAILED SYLLABUS:

##### UNIT- I: CONSTRUCTION CONTRACTS

(9 Periods)

Indian contracts act, Elements of contracts, Types of contracts, Features, Suitability, Design of contract documents, International contract document and laws, Standard contract document, Law of torts.

##### UNIT- II: TENDERS

(9 Periods)

Prequalification, Bidding, Accepting; Evaluation of tender from technical, contractual and financial points of view; Two cover system, Preparation of the documentation, Contract formation and interpretation, Potential contractual problems, Price variation clause, Comparison of actions and laws, Subject matter, Violations, Latest developments in tendering.

##### UNIT-III: ARBITRATION

(9 Periods)

Arbitration, Comparison of actions and laws, Agreements, Appointment of arbitrators, Conditions of arbitration, Powers and duties of arbitrator, Rules of evidence, Enforcement of award, Arbitration disputes, Dispute review board.

##### UNIT- IV: LEGAL REQUIREMENTS

(9 Periods)

Legal requirements for planning, Property law, Agency law, Tax laws – Income tax, Sales tax, Excise and custom duties, Local government approval, Statutory regulations, Insurance and bonding, Laws governing purchase and sale, Use of urban and rural land, Land revenue codes, EMD, Security deposits, Liquidated damages.

**UNIT – V: LABOUR REGULATIONS****(9 Periods)**

Social security, Welfare legislation; Laws relating to wages, bonus and industrial disputes; Labour administration, Insurance and safety regulations, Workmen's compensation act, Maternity benefit act, Child labour act, Other labour laws.

**Total Periods: 45**

**Topics for self-study are provided in the lesson plan**

**TEXT BOOKS:**

1. Subba Rao, G.C.V., *Law of Contracts I & II*, S. Gogia & Co., 11<sup>th</sup> Edition, 2011.
2. Jimmie Hinze, *Construction Contracts*, McGraw Hill, 3<sup>rd</sup> Edition, 2011.

**REFERENCES BOOKS:**

1. Kishore Gajaria, *GT Gajaria's Law Relating to Building and Engineering Contracts in India*, Lexis Nexis Butterworths India, 4<sup>th</sup> Edition, 2000.
2. Patil, B. S., *Civil Engineering Contracts and Estimates*, University Press (India) Private Ltd., 4<sup>th</sup> Edition, 2015.
3. Joseph T. Bockrath, *Contracts and the Legal Environment for Engineers and Architects*, McGraw Hill Education, 7<sup>th</sup> Edition, 2010.
4. Akhileshwar Pathak, *Contract Law*, Oxford University Press, 2011.

**ADDITIONAL LEARNING RESOURCES:**

1. P.C. Markanda, Naresh Markanda, Rajesh Markanda, *Building and Engineering Contracts- Law and Practice*, Vol-I and II, 5<sup>th</sup> Edition, LexisNexis Publication.



## II B. Tech. - II Semester

### (19BT40306) GLOBAL STRATEGY AND TECHNOLOGY

(Open Elective-2)

(Common to CE, ME, CSE, CSSE and IT)

| Int. Marks | Ext. Marks | Total Marks | L | T | P | C |
|------------|------------|-------------|---|---|---|---|
| 40         | 60         | 100         | 3 | - | - | 3 |

#### PREREQUISITES: -

**COURSE DESCRIPTION:** Introduction to strategic management; Strategic management process; Principles of good strategy; Globalization strategies; Research and Development strategies; Technology Management and Transfer; Elements of Transfer Process; Corporate Governance in the Indian scenario.

**COURSE OUTCOMES:** After successful completion of the course, students will be able to:

- CO1. Demonstrate the knowledge on strategic management, its approaches, and tools through ethical decision making.
- CO2. Analyze the globalization challenges for scrupulous selection of globalization strategies.
- CO3. Apply the R&D strategies and trends to enhance the technological breakthroughs for new products and applications.
- CO4. Demonstrate the knowledge on technology management and transfer that strengthen the economy and accelerate the application of technology and resources.
- CO5. Analyze the challenges of corporate governance in Indian scenario for the effective development of value oriented organizations.

#### DETAILED SYLLABUS:

##### UNIT- I: STRATEGIC MANAGEMENT

(9 Periods)

Introduction, Classes of decisions, Levels of strategy, Core competence, Strategic intent and stretch, Approaches to strategy making, Roles of different strategists, Strategic management-Process, Benefits, Limitations; Ethics in strategic decision making, Principles of good strategy, Strategic Management in India; Common managerial strategy formulation tools.

##### UNIT- II: GLOBALIZATION

(9 Periods)

Definition, Stages, Essential conditions for globalization, Globalization strategies, Competitive advantage of Nations and regions, Factors affecting Globalization, Globalization of Indian business.

##### UNI-T III: RESEARCH & DEVELOPMENT STRATEGIES

(9 Periods)

Concept, Evolution of R and D Management, R and D as a business, R and D as competitive advantage, Elements of R and D strategies, Integration of R and D, Selection and implementation of R and D strategies, R and D trends and challenges.

**UNIT – IV: TECHNOLOGY MANAGEMENT AND TRANSFER (9 Periods)**

**Technology Management:** Introduction, Technology-Definition, Components, Classification Features; Technology Management-Concept, Nature; Drivers of Management of Technology-Significance, Scope, Responding to technology challenges.

**Technology Transfer:** Introduction, Definition, Classification, Significance, Elements of process, Types of Technology Transfer, Package, Modes of Transfer, Routes, Channels and Effectiveness of Technology Transfer.

**UNIT - V: CORPORATE GOVERNANCE: THE INDIAN SCENARIO (9 Periods)**

Emergence of corporate governance in India-Landmarks, Models, Codes and status in India, Role and Responsibilities of Regulators, The Board of Directors; Corporate Governance- Specific issues in India, Family owned Business, Corporate Governance and the Indian ethos.

**Total Periods: 45**

***Topics for self-study are provided in the lesson plan***

**TEXT BOOKS:**

1. Francis Cherunilam, *Strategic Management*, Himalaya Publishing House, 3<sup>rd</sup>Edition, 2002.
2. C. S. G. Krishnamacharyulu and Lalitha Ramakrishnan, *Management of Technology*, Himalaya Publishing House, Second Edition, 2012.

**REFERENCE BOOKS:**

1. White and Bruton, *The Management of Technology and Innovation: A Strategic Approach*, Cengage Learning, 1<sup>st</sup>Edition, 2007.
2. S.K.Mandak, *Ethics in Business and Corporate Governance*, TMH, 2<sup>nd</sup>Edition, 2012.

**II B. Tech. - II Semester**  
**(19BT40307) MANAGEMENT SCIENCE**

(Open Elective-2)

(Common to CE, ME, CSE, CSSE and IT)

| Int. Marks | Ext. Marks | Total Marks | L | T | P | C |
|------------|------------|-------------|---|---|---|---|
| 40         | 60         | 100         | 3 | - | - | 3 |

**PRE-REQUISITES: -**

**COURSE DESCRIPTION:** Concepts of Management; Concepts Related to ethics and social responsibility; Human Resource Management; Operations Management; Statistical Process Control; Inventory Management; Marketing; Project Management; Project Crashing.

**COURSE OUTCOMES:** *After successful completion of the course, students will be able to:*

- CO1. Demonstrate the concepts of management, its functions and processes used in optimum resource utilization within the context of ethics and social responsibility.
- CO2. Apply the concepts of HRM for selection and management of human resources.
- CO3. Analyze different operations management problems using quality management tools to produce effective, efficient and adoptable products/services.
- CO4. Identify different marketing strategies to maximize enterprise profitability and customer satisfaction within the realistic constraints.
- CO5. Develop network models in time-cost tradeoff for effective project management.

**DETAILED SYLLABUS:**

**UNIT- I: MANAGERIAL FUNCTION AND PROCESS (10 Periods)**

Concept and foundations of management, Evolution of management thought; Managerial functions – Planning, Organizing, Directing and Controlling; Decision-making; Role of manager, managerial skills; Managing in a global environment, Flexible systems management; Social responsibility and managerial ethics; Process and customer orientation; Managerial processes on direct and indirect value chain.

**UNIT-II: HUMAN RESOURCE MANAGEMENT (8 Periods)**

Human Resource challenges; Human Resource Management functions; Human Resource Planning; Job analysis; Job evaluation, Recruitment and selection; Training and Development; Promotion and transfer; Performance management; Compensation management and benefits; Employee morale and productivity; Human Resource Information System.

**UNIT-III: OPERATIONS MANAGEMENT (10 Periods)**

Fundamentals of Operations Management, Services as a part of operations management; Facilities location and layout; Line balancing; Quality management – Statistical Process Control, Total Quality Management, Six sigma; Role and importance of materials management, Value analysis, Make or Buy decision, Inventory control, Materials Requirement Planning, Enterprise Resource Planning, Supply Chain Management.

**UNIT – IV: MARKETING MANAGEMENT****(8 Periods)**

Concept, evolution and scope; Marketing strategy formulation and components of marketing plan; Segmenting and targeting the market; Positioning and differentiating the market offering, Analyzing competition; Product strategy; Pricing strategies; Designing and managing marketing channels; Integrated marketing communications.

**UNIT – V: PROJECT MANAGEMENT****(9 Periods)**

Project management concepts; Project planning – Work Breakdown Structure, Gantt chart; Project scheduling – Critical Path Method, Program Evaluation and Review Technique, Crashing the project for time-cost trade off; Resource Levelling.

**Total Periods: 45**

***Topics for self-study are provided in the lesson plan***

**TEXT BOOKS:**

1. MartandT. Telsang, *Industrial Engineering and Production Management*, S. Chand, 2<sup>nd</sup> Edition, 2006.
2. Koontz and Wehrich, *Essentials of Management*, TMH, 6<sup>th</sup> Edition, New Delhi, 2007.

**REFERENCE BOOKS:**

1. O.P. Khanna, *Industrial Engineering and Management*, Dhanpat Rai and Sons, 2010.
2. N.D. Vohra, *Quantitative Techniques in Management*, TMH, 2<sup>nd</sup> Edition, New Delhi.
3. L.M. Prasad, *Principles and practice of Management*, S. Chand and Sons, 2006.

## II B. Tech. - II Semester

### (19BT40504) CYBER LAWS AND SECURITY

(Open Elective-2)

(Common to CE, ME, CSE, CSSE and IT)

| Int. Marks | Ext. Marks | Total Marks | L | T | P | C |
|------------|------------|-------------|---|---|---|---|
| 40         | 60         | 100         | 3 | - | - | 3 |

#### PRE-REQUISITES: -

**COURSE DESCRIPTION:** Evolution of Cyberspace, Jurisdiction in the borderless Cyberspace, E-Contracting, Models of E-Commerce, Modes of Electronic signatures, E-Money, Intellectual Property Rights, Cybercrimes, Privacy and data security.

**COURSE OUTCOMES:** After successful completion of the course, students will be able to:

- CO1. Demonstrate knowledge on jurisdiction in cyberspace and the impact of cybercrime to protect privacy on the Internet.
- CO2. Analyze the Indian cyber laws on E-Contracting, E-Commerce, E-signatures and E-money to promote digital law enforcement.
- CO3. Apply the knowledge of digital rights in Indian context to protect intellectual properties in electronic world.
- CO4. Practice ethics and cyber law regulations for leading electronic transactions on the Internet.

#### DETAILED SYLLABUS:

##### UNIT-I: EVOLUTION OF CYBERSPACE AND JURISDICTION IN BORDERLESS CYBERSPACE (9 Periods)

**The Evolution of Cyberspace:** Significance of information technology, Drawbacks in information technology, the digital divide, E-governance, Origin of cyberspace, Legal issues in cyberspace, regulating the Internet.

**Jurisdiction in the Borderless Cyberspace:** Meaning of jurisdiction, Three pre-requisites of jurisdiction, Jurisdictional theories in jurisdiction to prescribe, Tests to determine jurisdiction in Internet law cases, Indian laws to determine personal jurisdiction, Jurisdiction clauses in click wrap agreement.

##### UNIT-II: ELECTRONIC CONTRACTING AND ELECTRONIC COMMERCE (9 Periods)

**Electronic Contracting:** Formation of offline contracts under English common law, Fundamental requirements of an offline contract, Forming an E-contract through website, E-mail contracting, The Indian approach of E-contracts, Contract formation on the Internet and Information Technology Act 2000, B2C E-contracts.

**Electronic Commerce:** Models, Advantages, Restricted activities, Laws, India's information Technology Act2000, Online customer protection in India(B2B, B2C).

##### UNIT-III: ELECTRONIC SIGNATURES AND ELECTRONIC MONEY (9 Periods)

**Electronic Signatures:** The role of signatures, Significance of electronic signatures, Modes of electronic signatures, UNCITRAL model law on electronic signatures 2001, Cryptography, Role of certifying authority in PKI, The Indian Information Technology Act

and electronic signatures- Electronic signatures, Prescribed authentication mechanisms, Secure electronic record.

**Electronic Money:** E-Money, RBI's guidelines on mobile banking and payments, The current E-payment systems, Earlier E-payment systems, Credit cards, Use of SET in online payment system.

#### **UNIT- IV: INTELLECTUAL PROPERTY RIGHTS AND THE INTERNET WORLD**

**(9 Periods)**

Protecting copyright in the E-world, International organizations protecting Intellectual Property, Copyright issues on the Internet, Digital rights management, Patent protection and computer software, India and copyright protection for computer software, Business method patents- Position of Business methods patents in India, Trademark protection on the Internet, Cyber squatting, The Indian trademark law and legal remedies, Hyper linking and framing.

#### **UNIT - V: CYBERCRIMES AND PROTECTING PRIVACY ON INTERNET (9 Periods)**

**Cybercrimes:** What is cybercrime, Categories, Different kinds of cybercrime, Cybercrimes and Information Technology Act, 2000 - Territorial scope and applicability, India's national cyber security policy.

**Protecting Privacy on the Internet:** Meaning of privacy, Threat to privacy on the Internet, Use of cookies and web bugs, Terms of use and privacy policy, Government right to interception, Employee privacy rights, Indian legal framework for data protection and privacy, Challenges to right of privacy in India.

**Total Periods: 45**

***Topics for self-study are provided in the lesson plan***

#### **TEXT BOOK(S):**

1. Karnika Seth, *Computers Internet and New technology Laws*, LexisNexis, 2013.

#### **REFERENCE BOOKS:**

1. Sarika Gupta, Gaurav Gupta, *Information Security and Cyber Laws*, Khanna Publishing, 2019.
2. Vivek Sood, *Cyber Law Simplified*, McGraw Hill, 2018.
3. Pavan Duggal, *Textbook on Cyber Law*, Universal LexisNexis, 2019.

#### **ADDITIONAL LEARNING RESOURCES:**

- [https://swayam.gov.in/nd2\\_cec20\\_cs09/preview](https://swayam.gov.in/nd2_cec20_cs09/preview)
- [https://swayam.gov.in/nd2\\_nou19\\_cs08/preview](https://swayam.gov.in/nd2_nou19_cs08/preview)

## II B. Tech. – II Semester

### (19BT50208) INTELLECTUAL PROPERTY RIGHTS

(Open Elective-2)

(Common to CE, ME, CSE, CSSE and IT)

| Int. Marks | Ext. Marks | Total Marks | L | T | P | C |
|------------|------------|-------------|---|---|---|---|
| 40         | 60         | 100         | 3 | - | - | 3 |

#### PRE-REQUISITES: --

**COURSE DESCRIPTION:** Introduction to Intellectual Property; Trade Marks; Law of Copy Rights; Law of Patents; Trade Secrets; Unfair Competition; New Development of Intellectual Property.

**COURSE OUTCOMES:** After successful completion of the course, students will be able to:

- CO1. Understand the concepts of intellectual property right and new amendments enforced in filling intellectual property right.
- CO2. Understand the processes and principles of trade mark registration and apply them for registering trade mark.
- CO4. Understand the process and principles of copy rights for registration and judicial consequences for violating laws of copyright/patents.
- CO5. Understand the process and principles of trade secrets and judicial consequences for coping trade secrets.

#### DETAILED SYLLABUS:

##### UNIT-I: INTRODUCTION TO INTELLECTUAL PROPERTY (10 Periods)

Introduction and the need for intellectual property rights (IPR); types of intellectual property- Design, Geographical Indication; International organizations, agencies and treaties.

##### UNIT- II: TRADEMARKS (8 Periods)

Introduction to trademark, Purpose and function of trademarks, acquisition of trade mark rights, protectable matter, selecting and evaluating trade mark, trade mark registration processes.

##### UNIT – III: LAW OF COPYRIGHTS (9 Periods)

Fundamental of copy right law, originality of material, rights of reproduction, rights to perform the work publicly, copy right ownership issues, copy right registration, notice of copy right, international copy right law.

**Law of patents:** Foundation of patent law, patent searching process, ownership rights and transfer.

##### UNIT- IV: TRADESECRETS (9 Periods)

Trade secrete law, determination of trade secrete status, liability for misappropriations of trade secrets, protection for submission, trade secrete litigation.

**Unfair competition:** Misappropriation right of publicity, false advertising.

**UNIT- V: NEW DEVELOPMENT OF INTELLECTUAL PROPERTY (9 Periods)**

New developments in: trade mark law, copy right law, patent law, intellectual property audits. International overview on intellectual property; international - trade mark law, copy right law, international patent law, international development in trade secrets law.

**Total Periods: 45**

***Topics for self-study are provided in the lesson plan***

**TEXT BOOKS:**

1. Deborah, E. Bouchoux, *Intellectual property: The law of Trademarks, Copyright, Patents, and Trade Secrets*, Cengage learning, 4<sup>th</sup> edition, 2013.
2. PrabuddhaGanguli, *Intellectual property right - Unleashing the knowledge economy*, Tata McGraw Hill Publishing Company Ltd.

**REFERENCE BOOKS:**

1. Neeraj P and Khusdeep D. *Intellectual Property Rights*. India, IN: PHI learning Private Limited. 1<sup>st</sup> edition 2019.

**ADDITIONAL LEARNING RESOURCES:**

1. Subramanian, N., &Sundararaman, M. (2018). *Intellectual Property Rights – An Overview*. Retrieved from <http://www.bdu.ac.in/cells/ipr/docs/ipr-eng-ebook.pdf>
2. World Intellectual Property Organisation. (2004). *WIPO Intellectual property Handbook*. Retrieved from [https://www.wipo.int/edocs/pubdocs/en/intproperty/489/wipo\\_pub\\_489.pdf](https://www.wipo.int/edocs/pubdocs/en/intproperty/489/wipo_pub_489.pdf)



**II B. Tech. - II Semester**  
**(19BT50409) GREEN TECHNOLOGIES**

(Open Elective-2)

(Common to CE, ME, CSE, CSSE and IT)

| Int. Marks | Ext. Marks | Total Marks | L | T | P | C |
|------------|------------|-------------|---|---|---|---|
| 40         | 60         | 100         | 3 | - | - | 3 |

**PRE-REQUISITES: -**

**COURSE DESCRIPTION:** Principles of green engineering; Green communications; Green energy; Green computing; Green construction; Green manufacturing.

**COURSE OUTCOMES:** After successful completion of the course, students will be able to:

- CO1. Analyze energy efficient communication systems such as Telecommunication systems, ICT, Wireless networks and cellular networks by understanding the principles of green communications.
- CO2. Understand the impact of conventional energy sources on environment and realize the significance and principles of green energy sources for sustainability.
- CO3. Understand the environmental impacts of IT and approaches for Green IT.
- CO4. Analyze concepts of sustainable green construction using appropriate tools and techniques following latest developments and considering safety and environment besides communicating effectively in graphical form.
- CO5. Demonstrate the environmental impact of traditional manufacturing and explore the need for green manufacturing process promoting sustainability.

**DETAILED SYLLABUS:**

**UNIT –I: PRINCIPLES OF GREEN ENGINEERING AND GREEN COMMUNICATIONS (9 Periods)**

**Principles of Green Engineering:** Introduction, Definition of green engineering, Principles of green engineering

**Green Communications:** Introduction, Origin of Green Communications, Energy Efficiency in Telecommunication systems, Telecommunication system model and energy Efficiency, Energy saving concepts, Quantifying energy efficiency in ICT, Energy efficiency metrics of green wireless networks, Embodied energy of communication devices- Introduction, The extended energy model, Embodied/Operating Energy of a BS in Cellular network- A Case study; Energy efficient standards for wireline communications.

**UNIT- II: GREEN ENERGY (9 Periods)**

Introduction, green energy systems - composition, adverse impacts, Green energy and sustainability, the target and solution. Diversification and localization of energy systems, green energy and sustainable development. Energy sources and their availability. Green energy sources - solar energy, wind energy, geothermal energy, ocean energy, biomass and biogas.

**UNIT- III: GREEN IT****(9 Periods)**

Introduction, Awareness to Implementation: Green IT Trends, Green Engineering, Greening by IT: Using RFID for Environmental Sustainability, Smart Grids, Smart Buildings and Homes, Green Supply Chain and Logistics, Enterprise-Wide Environmental Sustainability, A Seven-Step Approach to Creating Green IT Strategy: Balancing the Costs and Benefits of Going Green, Research and Development Directions.

**UNIT- IV: GREEN CONSTRUCTION****(9 Periods)**

**Green Building:** Concept, Necessity, Characteristics, Benefits, Requisites for green building construction, Sustainability, Concept of REDUCE, REUSE, RECYCLE, RETHINK, REPLENISH AND REFUSE (6 R's), Sustainable construction focus point – Site selection, Planning, Water, Energy, Material, Indoor air quality, Construction procedures, case studies of residential and commercial green buildings.

**Vastu:** Concept, History, scientific approach, elements of vastu for selecting a plot.

**Indian Green Building Council:** Introduction to IGBC green homes, Benefits of IGBC, IGBC green home rating system, Introduction to USGBC, LEED rating system, Procedure to get IGBC certification, GRIHA Rating.

**UNIT- V: GREEN MANUFACTURING****(9 Periods)**

Green Manufacturing - Introduction, Background and Definition; Impact of traditional manufacturing in environmental ecology, Need for green manufacturing, Motivation and barriers to green manufacturing, Advantages and Limitations of green manufacturing, Green manufacturing strategies, Green manufacturing and sustainability, Green manufacturing through clean energy supply, Green packaging and Supply chain.

**Total Periods: 45**

**Topics for self-study are provided in the lesson plan**

**TEXT BOOKS:**

1. Konstantinos Samdanis, Peter Rost, Andreas Maeder, Michela Meo, Christos Verikoukis, *Green Communications: Principles, Concepts and Practice*, John Wiley & Sons, 2015.
2. G.D. Rai, *Non-conventional Energy Sources*, Khanna Publishers, Delhi, 5th Edition, 2011.
3. San Murugesan, G.R. Gangadharan, *Harnessing Green IT – Principles and Practices*, John Wiley & Sons Ltd., 2008.
4. Tom Woolley, Sam Kimmins, Paul Harrison and Rob Harrison, *Green Building Handbook*, Volume 1, E & FN Spon, an imprint of Thomson Science & Professional.
5. J Paulo Davim, *Green Manufacturing: Processes and Systems*, Springer, 2012.
6. David A Dornfeld, *Green Manufacturing: Fundamentals and Applications*, Springer, 2013.

**REFERENCE BOOKS:**

1. Soli J. Arceivala, *Green Technologies for a better future*, McGraw Hill Education (India) Pvt. Ltd, 2014.
2. Marty Poniatowski, *Foundation of Green Information Technology*, Prentice Hall, 2009.
3. Athanasios V Alavanidis, Thomais Vlachogianni, *Green Chemistry and Green Engineering*, Synchrone Themata, 2012.

**II B. Tech. –II Semester**  
**(19BT3HS31) SOFT SKILLS LAB**  
(Common to CSE, CSSE and IT)

| Int. Marks | Ext. Marks | Total Marks | L | T | P | C |
|------------|------------|-------------|---|---|---|---|
| 50         | 50         | 100         | - | - | 2 | 1 |

**PRE-REQUISITES: -**

**COURSE DESCRIPTION:** Body Language; Assertiveness; Goal Setting; Thinking Skills; Team Building; Conflict Management; Technical Report Writing; Résumé Writing; Group Discussions; Interview Skills; Interpersonal Skills; Etiquette.

**COURSE OUTCOMES:** *After successful completion of the course, students will be able to:*

- CO1. Demonstrate knowledge of career skills by examining and applying the styles and strategies of Goal Setting, Thinking Skills, and Etiquettes.
- CO2. Analyze the limitations and possibilities of favourable situations by applying the skills of Body Language and demonstrate through Assertiveness, and Interpersonal Skills.
- CO3. Apply appropriate soft skills by analyzing the problem situations that arise in professional career through demonstrating remedies in Conflict Management.
- CO4. Demonstrate ability to function effectively as an individual and as a member in diverse teams examining and applying soft skills in Interviews, Group Discussion and Team Building.
- CO5. Apply appropriate speaking and writing techniques in preparing documents and to communicate effectively by examining and demonstrating knowledge in Technical Report Writing and Résumé Writing.

**\*First TEN exercises are mandatory among the following:**

**LIST OF EXERCISES:**

**1. Body Language**

*Types of Body Language – Parts of Body – Facial Expressions – Eye Contact Insights – Good Posture*

**2. Assertiveness**

*Communications Styles – Benefits – Being Unassertive – Role Playing*

**3. Goal Setting**

*Seven Steps of Goal Setting – Self Motivation – Personal Goal Setting – Setting Career Goals*

**4. Thinking Skills**

*Positive Thinking – Creative Thinking – Lateral Thinking – Logical Thinking – Intuitive Thinking*

**5. Team Building**

*Learning Activities – Management Essentials – Team Building Scenarios*

**6. Conflict Management**

*Ways of Resolving Conflict – Personality Types and Conflict – Conflict Resolution Process – Team Conflict*

## **7. Technical Report Writing**

*Objectives – Formats – Writing Styles*

## **8. Résumé Writing**

*Structure and Presentation – Planning – Defining Career Objectives – Projecting One's Strengths and Skills – Cover Letter – Formats and Styles*

## **9. Group Discussions**

*Types of GD – Dos and Don'ts – Dynamics of GD – Intervention – Summarization Techniques*

## **10. Interview Skills**

*Planning – Opening Strategies – Answering Strategies – Tele Conferencing – Video Conferencing*

## **11. Interpersonal Skills**

*Starting a Conversation – Responding to a Conversation – Conversation Examples – Body Language – Role Play*

## **12. Etiquette**

*Basic Social Etiquette – Telephone Etiquette – Dining Etiquette – Conference Etiquette*

### **TEXT BOOKS:**

1. Soft Skills Lab Manual, SVEC.

### **REFERENCE BOOKS:**

1. R. C. Sharma & Krishna Mohan, *Business Correspondence and Report Writing*, Tata McGraw-Hill Publishing Company Limited, 3<sup>rd</sup> edition, New Delhi, 2012.

### **SUGGESTED SOFTWARES:**

1. KVAN SOLUTIONS
2. Learning to Speak English 8.1, The Learning Company – 4 CDs.
3. English in Mind, Herbert Puchta and Jeff Stranks with Meredith Levy, Cambridge.
4. Language in Use 1, 2 & 3.
5. Cambridge Advanced Learner's Dictionary - 3rd Edition.
6. Let's Talk English, Regional Institute of English South India.

**II B.Tech. – II Semester**  
**(19BT31232) SOFTWARE ENGINEERING LAB**  
 (Common to CSE and CSSE)

| Int. Marks | Ext. Marks | Total Marks | L | T | P | C |
|------------|------------|-------------|---|---|---|---|
| 50         | 50         | 100         | - | - | 2 | 1 |

**PRE-REQUISITES:** A course on "Software Engineering"

**COURSE DESCRIPTION:** Software Development Life Cycle activities-requirements specification, SRS preparation, Modeling case studies–Online Ticket Reservation system; Point of sales.

**COURSE OUTCOMES:** *After successful completion of the course, students will be able to:*

CO1. Analyse user requirements and prepare software requirements specifications.

CO2. Apply design principles of UML for software design.

CO3. Apply tools for developing UML diagrams.

CO4. Use cost estimation models for project evaluation.

CO5. Work effectively as an individual to design UML models.

CO6. Write and present a substantial technical report/document effectively.

**LIST OF EXPERIMENTS:**

1. Identify Functional and Non-Functional Requirements for:
  - i) Online Ticket Reservation for Railways
  - ii) Online Auction Sales
- 2.a) Construct a flow graph for Insertion sort algorithm.
  - b) Write a program to find Cyclomatic complexity for the above flow graph  
 (**Hint:** McCabe's cyclomatic matrices  $V(G)$  of a graph  $G$  with  $n$  vertices,  $e$  edges and  $P$  connected components is  $V(G)=e-n+2P$ )

**CASE STUDIES:**

Case studies given below should be Modeled using Visual Modeling tools in different views i.e. Use case view, logical view, component view, Deployment view.

**CASE STUDY 1: ONLINE TICKET RESERVATION FOR RAILWAYS**

**Problem Statement:** Computer play an integral part of the day in today's life. It makes the entire job easier and faster, every job is computerized so as the ticket reservation we can book over the online ticket reservation system. During the booking of the ticket reservation passenger has to select origin, date of journey, destination, class of train etc. The reservation counter keeps track of passenger's information. Thus the system will have all the details about the trains and facilities provided by them. There are various trains with the different level of convenience for the passengers. The whole database will be maintained by database administrator. There are varieties of trains where the passengers can select the train according to the convenience for their destination journey. The journey could be within the state or across the India. Each train has the three types of classes i.e. Sleeper class, First class and the AC compartment. Design the application for the above problem description.

## **CASE STUDY 2: A POINT OF SALE (POS) SYSTEM**

**Problem Statement:** A POS System is a computerized application used to record sales and handle payments; it is typically used in a retail store. It includes hardware components such as a computer and bar code scanner, and software to run the system. It interfaces to various service applications, such as a third-party tax calculator and inventory control. These systems must be relatively fault tolerant; that is, even if remote services and temporarily unavailable they must still be of capturing sales and handling at least cash payments. A POS system must support multiple and varied client – side terminals and interfaces such as browser, PDA's, touch – screens.

## **CASE STUDY 3: RECRUITMENT PROCEDURE FOR SOFTWARE INDUSTRY**

**Problem Statement:** In the software industry the recruitment procedure is the basic thing that goes in the hand with the requirement as specified by the technical management team. HR first gives an advertisement in leading Newspapers, Journals, Weeklies and Websites. The job seekers can apply for it through by Post or by e-mail to the company. The technical skill and the experience of the candidates are reviewed and the short listed candidates are called for the interview. There may be different rounds for interview like the written test, technical interview, and HR interview. After the successful completion of all rounds of interview, the selected candidates' names are displayed. Meanwhile HR gives all the details about the salary, working hours, terms and conditions and the retirement benefit to the candidate.

## **CASE STUDY 4: ONLINE AUCTION SALES**

**Problem Statement:** The online auction system is a design about a website where sellers collect and prepare a list of items they want to sell and place it on the website for visualizing. To accomplish this purpose the user has to access the site. In case it's a new user he has to register. Purchaser's login and select items they want to buy and keep bidding for it. Interacting with the purchasers and sellers through messages does this. There is no need for customer to interact with the sellers because every time the purchasers bid, the details will be updated in the database. The purchaser making the highest bid for an item before the close of the auction is declared as the owner of the item. If the auctioneer or the purchaser doesn't want to bid for the product then there is fixed cutoff price mentioned for every product. He can pay that amount directly and own the product. The purchaser gets a confirmation of his purchase as an acknowledgement from the website. After the transition by going back to the main menu where he can view other items.

## **CASE STUDY 5: TWO FLOOR ELEVATOR SIMULATOR**

**Problem Statement:** The elevator has the basic function that all elevator systems have, such as moving up and down, open and close doors, and of course, pick up passengers. The elevator is supposed to be used in a building having floors numbered from 1 to Max Floor, where the first floor is the lobby. There are car call buttons in the car corresponding to each floor. For every floor except for the top floor and the lobby, there are two hall call buttons for the passengers to call for going up and down. There is only one down hall call button at the top floor and one up hall call button in the lobby. When the car stops at a floor, the doors are opened and the car lantern indicating the current direction the car is going is illuminated so that the passengers can get to know the current moving direction of the car. The car moves fast between floors, but it should be able to slow down early enough to stop at a desired floor. When an elevator has no requests, it remains at its current floor with its doors closed.

In order to certificate system safety, emergency brake will be triggered and the car will be forced to stop under any unsafe conditions.

## **CASE STUDY 6: HOME APPLIANCE CONTROL SYSTEM**

**Problem Statement:** A home appliance control system (HACS) is a system which provides various services to remotely operate on home appliances, such as microwave oven, TV, and garage door etc through remote devices such as mobile phone, desktop and palm-top. A home appliance control system (HACS) is a system which is controlled by a remote system such as a mobile phone or a palm-top, and at the same time controls, monitors and coordinates home appliances such as air conditioner, microwave oven, garage doors, TV set, VCR, audio controller, indoor/outdoor lights, water sprinkler, home security system, bath tub controller, etc. In order to activate home appliances and to allow for different ways of cooking, the HACS needs mechanisms for communication between the different devices in the system, and for coordination among the various processes running on such devices. The system administrator of the HACS system has the ability to add a new appliance or delete an existing one. The system administrator has the ability to add a new remote device and configure it with HACS or delete an existing one when it is not used. Also the system administrator can create an account for a new user or delete existing account if it is no longer used.

### **REFERENCE BOOKS:**

1. Grady Booch, James Rum Baugh and Ivar Jacobson, "The Unified Modeling Language User Guide," Second Edition, Pearson Education, 2009.
2. Hans-Erik Eriksson, Magnus Penker, Brian Lyons and David Fado, "UML 2 Toolkit," WILEY-Dreamtech India Pvt. Ltd., 2003.
3. Rajesh Naik and Swapna Kishore, "Software Requirements and Estimation," Tata McGraw Hill, New Delhi, 2001.

### **SOFTWARE/TOOLS USED:**

Visual Paradigm for modeling diagrams

## II B. Tech. - II Semester

### (19BT40531) COMPUTER NETWORKS LAB

(Common to CSE and IT)

| Int. Marks | Ext. Marks | Total Marks | L | T | P | C |
|------------|------------|-------------|---|---|---|---|
| 50         | 50         | 100         | - | - | 2 | 1 |

**PRE-REQUISITES:**A course on "Computer Networks"

**COURSE DESCRIPTION:** Hands on practice with NS3; Packet Tracer network simulation tools; Simulation of network topologies; ARP protocol; CSMA/CD protocol; Distance Vector/Link State Routing protocols; Transmission errors; Sliding window protocol; TCP; UDP.

**COURSE OUTCOMES:** *After successful completion of the course, students will be able to:*

- CO1. Apply mathematical foundations to solve computational problems in computer networks.
- CO2. Select and apply network simulation tools like NS3, Packet Tracer to simulate networking protocols.
- CO3. Simulate and analyze network topologies, network protocols to provide efficient networking solutions.
- CO4. Work independently and communicate effectively in oral and written forms.

#### LIST OF EXERCISES:

1. a) Study of network devices and network IP in detail.  
b) Simulate a peer to peer topology of a computer network.  
c) Simulate IPv4 addressing in a computer network (give IP Address of different classes in given Network id).

#### Exercises on Packet Tracer Simulator Tool:

2. Introduction to Packet Tracer
3. a) Study of basic network commands and network configuration commands.  
i) ping ii) nslookup iii) netstat iv) ifconfig  
b) Create a network topology and configure a network topology with four PCs, two switches, and two routers.

#### Exercises on NS3 Simulator Tool:

4. a) Introduction to NS3 tool.  
b) Create a network with three nodes namely 0, 1 and 2. Establish a TCP connection between node 0 and node 2 such that node 0 will send TCP packets to node 2 via node 1.
5. a) Create a simple topology of two nodes (Node1, Node2) separated by a point-to-point link. Setup a UDP Client on one Node1 and a UDP Server on Node2. Consider a fixed data rate Rate1.



- i) Measure end to end throughput whilst varying the latency of the link.
    - ii) Add another client application to Node1 and a server instance to Node2. What do you need to configure to ensure that there is no conflict?
    - iii) Repeat step 3 with the extra client and server application instances. Show screenshots of pcap traces which indicate that delivery is made to the appropriate server instance.
  - b) Simulate a Local Area Network. Consider a local area network formed by nodes 3, 4, and 5. This LAN communicates with the external world through a router denoted by node 2. There are two servers connected to the router and represented by nodes 0 and 1. Node 0 is running an application over TCP, which is accessed by node 4. Node 1 is running an application on UDP, which is accessed by node 5. Analyze the trace file.
6. Simulate link errors. Presence of link errors cause one or more packets to be retransmitted. Consider the following topology.

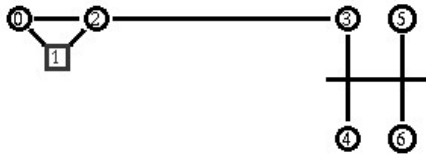

- Node #2 act as a router. Any traffic to or from the LAN passes through it. Consider node #1 running a FTP server, and node #5 is downloading a file of size 4 MB. However, the link between node #2 and #3 is fault. It drops packets with a fixed probability of 0.2. Implement a link error model to reflect this. Try different values of the simulation time to ensure that the file has been entirely transferred. Has the plot of bytes received a linear curve or non-linear? Why?
7. Simulate Address Resolution Protocol (ARP) to associate a logical address with a physical address and Reverse Address Resolution Protocol (RARP) allows a host to discover its Internet address when it knows only its physical address.
  8. Simulate packet transmission over a CSMA/CD based LAN with NS3. Consider the LAN with seven nodes to be an isolated one i.e. not connected to the Internet. Node #0 in the LAN acts as a UDP traffic source, and node #6 is the destination node. Assume CBR traffic to be flowing between the nodes. The simulation lasts for 25 seconds. In Ethernet a packet is broadcasted in the shared medium, and only the destination node accepts the packet. Other nodes simply drop it. What should be the number of hops a packet from node #0 to node # 6 travel? Verify this from the "Hop Count" plot.
  9. a) UDP uses a simple connectionless communication model with a minimum of protocol mechanism. The implementation provides checksums for data integrity, and port numbers for addressing different functions at the source and destination of the datagram. Simulate half duplex chat User Datagram Protocol.
  - b) TCP model supports a full bidirectional TCP with connection setup and close logic. Simulate full duplex chat Transmission Control Protocol.
  10. a) In a typical FTP session, the user is sitting in front of one host (the local host) and wants to transfer files to or from a remote host. Implement File Transfer Protocol

to move files between local and remote file systems.

- b) Sliding window protocol supports reliable and efficient transmission between nodes and it also obtains higher throughput than that of stop-n-wait protocol. Simulate sliding window protocol normal operation and timeout operations.

11. Configure the following network to find shortest path between R2 LAN to R3 LAN using Distance Vector / Link State Routing Protocol.

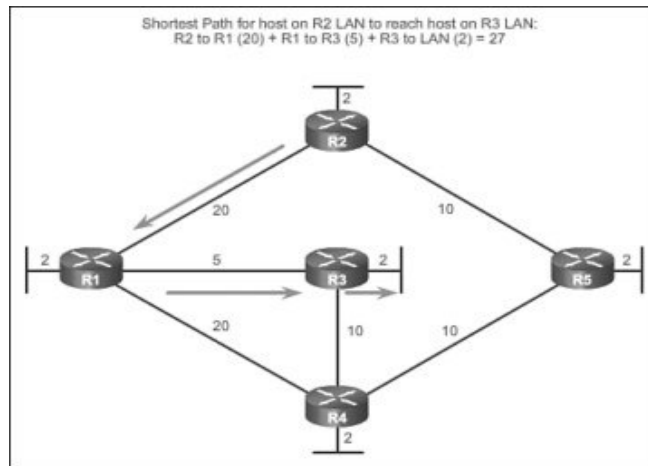

#### REFERENCE BOOKS:

1. Andrew S. Tanenbaum and David J. Wetherall, *Computer Networks*, Pearson, 5<sup>th</sup> Edition, 2015.
2. A. Jesin, *Packet Tracer Network Simulator*, Packt Publishing, 2014.
3. Jack L. Burbank, *An Introduction to Network Simulator 3*, Wiley, 2018.

#### Software/Tools used:

- Network simulator tools - NS3, Packet Tracer
- Virtual Labs (Computer Networks Lab – [http://vlabs.iitb.ac.in/vlabs-dev/labs\\_local/computer-networks/labs/explist.php](http://vlabs.iitb.ac.in/vlabs-dev/labs_local/computer-networks/labs/explist.php))
- Virtual Labs (Advanced Network Technologies Virtual Lab - <http://vlabs.iitkgp.ernet.in/ant>)

## II B. Tech. - II Semester

### (19BT40532) DATABASE MANAGEMENT SYSTEMS LAB

(Common to CSE, CSSE and IT)

| Int. Marks | Ext. Marks | Total Marks | L | T | P | C |
|------------|------------|-------------|---|---|---|---|
| 50         | 50         | 100         | - | - | 2 | 1 |

**PRE-REQUISITES:** A course on "Database Management Systems"

**COURSE DESCRIPTION:** Design of an ER Models; Hands-on experience on - DDL, DML commands, Query processing using operators, Joins, Views, Synonyms, Indexes, Single row functions, Group functions and Set functions; PL/SQL programming - Basic programs, Exception handling, Triggers, Functions, Cursors and Stored procedures.

**COURSE OUTCOMES:** After successful completion of the course, students will be able to:

- CO1. Analyze the requirements of a given database problem and design viable ER-Models for implementation of database.
- CO2. Create database schemas, select and apply suitable integrity constraints for querying databases using SQL interface.
- CO3. Develop and interpret PL/SQL blocks to centralize database applications for maintainability and reusability.
- CO4. Develop database applications for societal applications such as ticket reservation system, employee payroll system using modern tools.
- CO5. Work independently and communicate effectively in oral and written forms.

#### LIST OF EXERCISES:

1. Design and analyze an ER Model for the following use case.  
Roadway Travels" is in business since 1977 with several buses connecting different places in India. Its main office is located in Hyderabad. The company wants to computerize its operations in the following areas:
  - o Reservations
  - o Ticketing
  - o Cancellations

Reservations:  
Reservations are directly handled by booking office. Reservations can be made 60 days in advance in either cash or credit. In case the ticket is not available, await listed ticket is issued to the customer. This ticket is confirmed against the cancellation.

Cancellation and Modification:  
Cancellations are also directly handed at the booking office. Cancellation charges will be charged. Waitlisted tickets that do not get confirmed are fully refunded.
2. a) Implement Data Definition Language commands -Create, Alter, Drop, Truncate, and Rename.  
b) Implement Data Manipulation Language commands - Insert, Select, Update, and Delete.

- c) Implement Single Row functions - Character, Numeric and Date functions.
- 3. Implement various types of integrity constraints - NOT NULL constraint, DEFAULT constraint, UNIQUE constraint, PRIMARY key, FOREIGN key, CHECK constraint.
- 4. a) Implement group functions with different operators such as aggregate operators, group by, having and order by.  
b) Implement nested and correlated nested queries using set operators and set comparison operators.
- 5. a) Creation of views, synonyms, sequence, indexes and save point.  
b) Implement various types of joins - outer join and inner join.

**Basic PL/SQL:**

- 6. Construct PL/SQL block for the following.
  - a) To determine whether a number is palindrome
  - b) To determine whether a number is an Armstrong number
  - c) To find greatest of three numbers
  - d) To display Fibonacci series

**Control Structures:**

- 7. a) Write a program in PL/SQL to update the salary of a specific employee by 8% if the salary exceeds the mid-range of the salary against this job and update up to mid-range if the salary is less than the mid-range of the salary, and display a suitable message.  
b) Write a PL/SQL program to display the description against a student's grade using CASE statement.

**Exception Handling:**

- 8. a) Develop a PL/SQL program that displays the name and address of a student whose ID is given. If there is no student with the given student ID in the database, the program should raise a run-time exception NO\_DATA\_FOUND, which should be captured in the EXCEPTION block.  
b) Construct the user-defined exceptions to get the salary of an employee and check it with the job's salary range. If the salary is below the range, raise an exception BELOW\_SALARY\_RANGE. If the salary is above the range, raise the exception ABOVE\_SALARY\_RANGE.

**Functions:**

- 9. a) Write a function that accepts two numbers A and B and performs the following operations.
  - o Addition
  - o Subtraction
  - o Multiplication
  - o Division

- b) Write a PL/SQL block that updates salary of an employee in Employee table by using incr function which takes employee number as argument and calculates increment and returns increment based on the following criteria.  
If salary <= 3000, increment = 30% of salary  
If salary > 3000 and <= 6000, increment = 20% of salary  
else increment = 10% of salary

**Procedures:**

10. a) Write a procedure that accepts two numbers and displays their sum.  
b) Write procedures to demonstrate IN, IN OUT and OUT parameters.

**Cursors:**

11. a) Write a block in PL/SQL to create a Cursor that displays the employee name and number of jobs he or she has done in the past.  
b) Write a program in PL/SQL to create a cursor to display the name and salary of each employee in the EMPLOYEES table whose salary is less than that specified by a passed-in parameter value.

**Triggers:**

12. Develop a suitable student database application by considering appropriate attributes.  
Couple of attributes to be maintained is the attendance of a student in each subject for which he/she has enrolled and internal assessment Using TRIGGERS for the following
- a) Whenever the attendance is updated, check if the attendance is less than 85%; if so, notify the concerned head of the department.  
b) Whenever, the marks in an internal assessment test are entered, check if the marks are less than 40%; if so, notify the concerned head of the department.

**REFERENCE BOOKS:**

1. Satish Ansani, *Oracle Database 11g: Hands-on SQL and PL/SQL*, PHI, 2010.
2. Pranab Kumar Das Gupta, P. Radha Krishna, *Database Management System Oracle SQL and PL/SQL*, PHI, 2<sup>nd</sup> Edition, 2009.

## II B.Tech. - II Semester

### (19BT3MC01) ENVIRONMENTAL SCIENCE

(Mandatory Course)

(Common to CE, ME, CSE, CSSE and IT)

| Int. Marks | Ext. Marks | Total Marks | L | T | P | C |
|------------|------------|-------------|---|---|---|---|
| 40         | -          | 40          | 2 | - | - | - |

#### PRE-REQUISITES: -

**COURSE DESCRIPTION:** Natural resources; Ecosystems; Biodiversity; Environment pollution and control; Social issues and environment; Human population and environment.

**COURSE OUTCOMES:** After successful completion of the course, students will be able to:

- CO1. Analyze natural resources to solve complex environmental problems and natural resource management considering society, environment and sustainability.
- CO2. Analyze ecosystems and biodiversity to solve complex environmental problems by following environmental ethics considering society, environment and sustainability besides communicating effectively in graphical form.
- CO3. Analyze various types of pollution and their control measures to solve environmental problems through appropriate tools and techniques following latest developments considering society, ethics, environment and sustainability.
- CO4. Analyze social issues and its impact on environment, environmental acts to solve complex environmental problems considering society, environment and sustainability besides communicating effectively in graphical form.
- CO5. Analyze human population and its impact on environment to solve complex environmental problems through team work and using appropriate tools and techniques considering ethics, society, environment and sustainability.

#### DETAILED SYLLABUS:

##### UNIT- I: NATURAL RESOURCES

(7 Periods)

Multidisciplinary nature of environment; Natural Resources: Renewable and non-renewable resources; Forest, Water, Mineral, Food and Energy resources -Causes, Effects, Remedies, Case studies; Role of an individual in conservation of natural resource and equitable use of resources for sustainable lifestyles.

##### UNIT- II: ECOSYSTEMS AND BIODIVERSITY

(7 Periods)

**Ecosystems:** Concept of an ecosystem, Structure and function of an ecosystem - Producers, Consumers, Decomposers; Food chains, Food webs, Ecological pyramids - Types; Characteristic features, Structure and functions of forest ecosystem, Desert ecosystem, Aquatic ecosystem.

**Biodiversity:** Concept and value of biodiversity, Role of biodiversity in addressing new millennium challenges, Hot spots of biodiversity, Threats to biodiversity, Man-wild life conflicts, Endemic, Endangered and extinct species of India, Conservation of biodiversity - In-situ and ex-situ.

**UNIT- III: ENVIRONMENTAL POLLUTION AND CONTROL (6 Periods)**

Causes, Adverse effects and control measures of pollution - Air pollution, Water pollution, Soil pollution, Noise pollution, Thermal pollution, Nuclear pollution, Solid waste management – Urban waste, industrial waste; Latest developments in pollution control, Hazards and disaster management – Floods, Earthquakes, Tsunamis, Case studies.

**UNIT- IV: SOCIAL ISSUES AND THE ENVIRONMENT (6 Periods)**

Sustainable development, Urban problems related to energy, Environmental ethics – Issues, Solutions; Global warming, Acid rain, Ozone layer depletion, Nuclear accidents and case studies, Wasteland reclamation, Consumerism and waste products, Concept of green technologies, Environment justice: National Green Tribunal and its importance; Environment protection act, Air act, Water act, Wildlife protection act, Forest conservation act, Issues involved in enforcement of environmental legislation, Public environmental awareness.

**UNIT- V: HUMAN POPULATION AND THE ENVIRONMENT (4 Periods)**

Population growth, Population characteristics and variation among nations, Population explosion, Family welfare programme, Environment and human health, Human rights, Value education, HIV/AIDS, Women and child welfare, Role of information technology in environment and human health; Case studies - Field Work/Assignment/Seminar on Environmental assets – Water bodies/Forest/Grassland/Hill/Mountain.

**Total Periods: 30**

***Topics for self-study are provided in the lesson plan***

**TEXT BOOKS:**

1. AnubhaKaushik and C. P. Kaushik, *Perspectives in Environmental Studies*, New Age International (P) Ltd. Publications, 6<sup>th</sup>Edition, 2018.
2. Erach Barucha, *Environmental Studies*, Orient Blackswan, 2<sup>nd</sup>Edition, 2013.

**REFERENCE BOOKS:**

1. Cunningham W.P. and Cunningham M.A., *Principles of Environmental Science*, Tata McGraw-Hill Publishing Company, New Delhi, 8<sup>th</sup> Edition, 2016.
2. Benny Joseph, *Environmental Studies*, Tata McGraw-Hill, 2<sup>nd</sup>Edition, 2009.
3. M. Anji Reddy, *Text Book of Environmental Sciences and Technology*, BS Publications, 2014
4. R. Rajagopalan, *Environmental Studies*, Oxford University Press, 2<sup>nd</sup> Edition, 2011.

**ADDITIONAL LEARNING RESOURCES:**

1. B. S. Chauhan, *Environmental Studies*, University Science Press, 2<sup>nd</sup> Edition, 2018.
2. Botkin and Keller, *Environmental Science: Earth as a Living Planet*, John Wiley & Sons, 8<sup>th</sup> International Student Edition, 2011.