



SREE VIDYANIKETHAN ENGINEERING COLLEGE

(AUTONOMOUS)

Sree Sainath Nagar, Tirupati

Department of Computer Science and Engineering

Supporting Document for 1.1.2

Syllabus Revision carried out in 2016

Program: M.Tech.- Computer Networks and Information Security

Regulations : SVEC-16

This document details the following:

1. Courses where syllabus has been changed 20% and more.
2. Course-wise revised syllabus with changes highlighted.

Note: For SVEC-16 revised syllabus, SVEC-14 (previous syllabus) is the reference.

**List of Courses where syllabus content has been changed
(20% and more)**

S. No.	Course Code	Name of the course	Percentage of content changed	Page Number in which Details are Highlighted
1.	16MT22505	Web Technologies	49	1
2.	16MT16301	Design of Secure Protocols	60	5
3.	16MT16302	Ethical Hacking	100	9
4.	16MT10507	Internet of Things	100	11
5.	16MT16331	Computer Networks & Information Security Lab	50	13
6.	16MT16332	Web Technologies Lab	45.5	17
7.	16MT20502	Big Data Analytics	100	22
8.	16MT12501	Cloud Computing	52.7	26
9.	16MT26301	Intrusion Detection Systems	20	30
10.	16MT26302	Network Programming	100	34
11.	16MT10506	Information Retrieval Systems	100	36
12.	16MT26304	Computer Forensics	35	38
13.	16MT26305	Database Security	20	42
14.	16MT26306	Social Networks	100	46
15.	16MT20531	Cloud Computing & Big Data Analytics Lab	100	48
16.	16MT26331	Wireless Networks Lab	50	52
17.	16MT23810	Intellectual property Rights	100	57
Average % (A)			69.54	
Total No. of Courses in the Program (T)			28	
No. of Courses where syllabus (more than 20% content) has been changed (N)			17	-
Percentage of syllabus content change in the courses (C)=(A x N)/100			11.82	
Percentage of Syllabus Content changed in the Program (P)= C/T			42.22	



DEAN (Academics)
DEAN (Academic)

SREE VIDYANIKETHAN ENGINEERING COLLEGE
Sree Sainath Nagar, A. RANGAMPET
CHITTOOR (DT.)-517 102, A.P.



PRINCIPAL
PRINCIPAL

SREE VIDYANIKETHAN ENGINEERING COLLEGE
(AUTONOMOUS)
Sree Sainath Nagar, A. RANGAMPET
Chittoor (Dist.) - 517 102, A.P., INDIA.

SREE VIDYANIKETHAN ENGINEERING COLLEGE (Autonomous)
Department of Computer Science and Engineering
I M. Tech (CN&IS) I-Semester
(16MT22505) WEB TECHNOLOGIES

Int. Marks	Ext. Marks	Total Marks	L	T	P	C
40	60	100	4	-	-	4

PREREQUISITES:

A course on "Object Oriented Programming"

COURSE DESCRIPTION:

Web Technologies: HTML5, CSS, JavaScript, JQuery; Open source server-side scripting language- PHP; MySQL database concepts; and AJAX

COURSE OUTCOMES:

On successful completion of this course, the students will be able to:

- CO1. Gain knowledge on web technologies.
- CO2. Analyze the functionality of client as well as server side web technologies for validating web pages.
- CO3. Gain programming skills to design and develop novel web applications
- CO4. Apply web technologies to make web pages more interactive, scalable and user friendly web applications.

DETAILED SYLLABUS

UNIT-I: HTML5 AND CSS3 (Periods: 14)

HTML5: Overview of HTML and XHTML, HTML5 - Introduction, HTML5 Document Structure, Creating Editable Content, Checking Spelling Mistakes, Exploring Custom Data Attributes, Microdata, Client-Side Storage, Drag and Drop Feature, ARIA Accessibility, Offline Web Applications, Web Communications, Cross-Document Messaging and Desktop Notifications, 2D and 3D Graphics; **CSS3:** Introduction, Features of CSS3, Syntax of CSS, Exploring CSS selectors, Inserting CSS in HTML Document, State of CSS3.

UNIT-II: JAVASCRIPT AND JQUERY (Periods: 10)

JavaScript: Overview of JavaScript, JavaScript Functions, Events, Image Maps and Animations, JavaScript Objects; **JQuery:** Fundamentals of JQuery, JQuery Selectors, JQuery Methods to Access HTML Attributes and Traversing, JQuery Manipulators, Events and Effects.

UNIT-III: INTRODUCTION TO PHP (Periods: 10)

Introduction, Data Types, Variables, Constants, Expressions, String Interpolation, Control Structures, Functions, Arrays, Embedding PHP Code in Web Pages, Object Oriented PHP.

UNIT-IV: PHP AND MYSQL (Periods:10)

PHP and Web Forms, Sending Form Data to a Server, Authenticating Users with PHP, Session Handlers, PHP with MySQL, Interacting with the Database, Database Transactions.

UNIT-V: AJAX (Periods:08)

Exploring Different Web Technologies, Exploring AJAX, Creating a Sample AJAX Application, Displaying Date and Time using AJAX, Creating the XMLHttpRequest Object, Reading a File Synchronously and Asynchronously, Reading Response Headers, Loading List Boxes Dynamically using XMLHttpRequest Object, JQuery with AJAX, Validating a Field using AJAX and PHP.

[Total Periods: 52]

TEXT BOOKS:

1. Kogent Learning Solutions Inc, "*HTML 5 Black Book: Covers CSS3, JavaScript, XML, XHTML, AJAX, PHP and JQuery*," 1ed, Dreamtech Press, 2011.
2. W. Jason Gilmore, "*Beginning PHP and MySQL*," 4ed, APress, 2011.

REFERENCE BOOKS:

1. Andrea Tarr, "*PHP and MySQL*," 1st Edition, Willy India, 2012.
2. Thomas A. Powell, "*The Complete Reference: HTML and CSS*," 5ed, Tata McGraw Hill, 2010.
3. Steve Suehring, Tim Converse and Joyce Park, "*PHP6 and MySQL*," 1ed, Willy India, 2009.
4. P. J. Deitel and H. M. Deitel, "*Internet & World Wide Web How to Program*," 4ed, Pearson, 2009.

**M Tech (CN&IS) II- Semester
(14MT20505) WEB PROGRAMMING**

Int Marks	Ext Marks	Total Marks	L	T	P	C
40	60	100	4	--	--	4

PRE-REQUISITES: Courses on "Programming in C" and "JAVA"

COURSE DESCRIPTION:

Introduction to HTML, Cascaded Style sheets and Java Scripting; Dynamic HTML and XML; PHP and Web Forms; Web Applications using PHP and MYSQL

COURSE OUTCOMES:

On successful completion of this course the students will be able to:

- CO1. Gain knowledge in
- HTML , CSS styling
 - Dynamic HTML with Java Script and XML
 - PHP dynamic programming and interaction with databases
- CO2. Analyze the design problems in HTML Web pages with CSS
- CO3. Design a dynamic webpage with HTML, CSS, Java Script, PHP concepts
- CO4. Assess the HTML Website using XML Parsers
- CO5. Create website of societal context for awareness on social and environmental issues

UNIT – I: INTROUCTION TO HTML AND CSS (Periods:11)

Hyper Text Markup Language-Basic HTML, the Document Body, Text, Hyper Links, Adding More Formatting, Lists Using Color and Images, Images

More HTML-Tables, Multimedia Objects, Frames, Forms towards Interactivity, The HTML Document Head in detail.

Cascading Style Sheets-Introduction, Using Styles, Defining Styles, Properties and Values in Style Sheets, Formatting Blocks of Information, Layers

UNIT – II: JAVA SCRIPTING (Periods:11)

An Introduction to Java Script-Dynamic HTML, **Java Script**-Basics, Variables, String Manipulation, Mathematical Function, Statements, Operators, Arrays, Functions.

Objects in Java Script-Data and Objects in Java Script, Regular Expressions, Exception Handling, Built in Objects, Cookies, and Events.

UNIT –III: ADVANCED JAVASCRIPTING AND XML (Periods:12)

Dynamic HTML With JavaScript: Data Validation, Opening in a new window, Messages and Confirmations, The Status Bar, Writing to a different frame, Rollover Buttons, Moving Images, A Text Only Menu System, Floating Logos.

XML: Defining Data for Web Applications: Basic XML, Document Type Definition, XML Schema, Document Object Model, Presenting XML, Using XML Parser

UNIT – IV: PREPROCESSOR HYPERTEXT PROGRAMMING

(Periods:14)

An Introduction To PHP: Introducing PHP, Including PHP in a HTML Page, Data Types, Program Control Structures, Arrays, User Defined Functions, Built-in Functions, Regular Expressions, Using files.

Advanced PHP: PHP and Web Forms, **Handling File Uploads-** Uploading files with PHP, Session Handlers: Working with Sessions.

UNIT – V: BUILDING WEB APPLICATIONS WITH PHP AND MYSQL

(Periods:07)

Building Web Applications With PHP And MYSQL-Handling Installation Prerequisites, **Using the mysqli Extension** - Setting Up and Tearing down the Connection, Handling Connection Errors, Retrieving Error Information, Storing Connection Information in a Separate File, Securing Your Connection Information.

Interacting with the Database - Sending a Query to the Database, Parsing Query Results, Determining the Rows Selected and Rows Affected, Working with Prepared Statements, Executing Database Transactions, and Enabling Auto commit Mode, Committing a Transaction, Rolling Back a Transaction.

Total Periods: 56

TEXT BOOKS:

1. Chris Bates, *"Web Programming: Building Internet Applications,"* Third Edition. New Delhi, India: Wiley India Pvt. Ltd., 2009.
2. W Jason Gilmore, *"Beginning PHP and MySQL: From Novice to Professional,"* Fourth Edition, New Delhi, India, Springer India Pvt Ltd., 2011.

REFERENCE BOOKS:

1. Robin Nixon, *"Learning PHP, MySQL, and JavaScript,"* Second Edition, Sebastopol, CA: O'Reilly Media, Inc., 2012.
2. Kevin Tatroe, Peter MacIntyre, and Rasmus Lerdorf, *"Programming PHP,"* Third Edition, Sebastopol, CA: O'Reilly Media, Inc., 2002.
3. Marc Wandschneider, *"Core Web Application Development with PHP and MySQL,"* First Edition, Prentice Hall Professional Technical Reference, 2006

SREE VIDYANIKETHAN ENGINEERING COLLEGE (Autonomous)
Department of Computer Science and Engineering
M. Tech (CNIS) I-Semester
(16MT16301) DESIGN OF SECURE PROTOCOLS
(Professional Elective-1)

Int. Marks	Ext. Marks	Total Marks	L	T	P	C
40	60	100	4	-	-	4

PRE-REQUISITES:

A Course on "Cryptography and Network Security, "

COURSE DESCRIPTION:

Pseudo-random-Bit generation and algorithm modes; Symmetric and asymmetric cryptography; Authentication protocols and Hash functions; Modern cryptography and its applications, Security implementations over resource constrained networks.

COURSE OUTCOMES:

After successful completion of this course, the students will be able to:

- CO1. Gain advanced knowledge on Basic Cryptography Techniques Pseudo-random-Bit generators used in Cryptography.
- CO2. Analyze various Authentication Protocols and security threats of systems against various attacks possible over the Internet services to provide secure access to the system.
- CO3. Solve the security issues by adopting mathematical and logical operators such as hash functions.
- CO4. Carryout research on advanced and modern Cryptographic protocol solutions to resolve security problems in the real world.
- CO5. Evaluate the use of Cryptographic algorithms and tools in providing security to resource constraint networks and e-commerce systems.

DETAILED SYLLABUS:

UNIT-I: BASICS OF CRYPTOGRAPHY (10 Periods)

Mathematics for Cryptography: Modular arithmetic, Finite fields, Primarily testing, Discrete Logarithms and Chinese Remainder theorem

Pseudo-random-Bit: Introduction, Random Bit Generation, Pseudo-random-Bit generation, Statistical Tests, Cryptographically Secure Pseudo-random-Bit Generation, Linear Congruential Generators, Linear Feedback Shift Registers, Stream Ciphers Using LFSRs.

UNIT-II: AUTHENTICATION PROTOCOLS (12 Periods)

Basic Authentication Techniques, Password based Authentication, The one-time-pad encryption scheme, Authenticated Key Exchange Based on Asymmetric Cryptography, Typical Attacks on Authentication Protocols, SSH, Kerberos Protocol.

IP SECURITY: Attacks against naming and addressing in the Internet, Security protocols for address resolution and address auto configuration, Security for global IP mobility, IP Security (IP Sec) protocol.

UNIT-III: ONE-WAY HASH FUNCTIONS (10 Periods)

Background, N-Hash, Ripe-MD, Haval, Other One-Way Hash Functions, One-Way Hash Function using Symmetric Block Algorithms, Using Public–Key Algorithms, Choosing a One- Way Hash Functions, Advanced Attacks on Hash Functions, Message Authentication Codes, The birthday attack.

UNIT-IV: MODERN CRYPTOGRAPHIC APPLICATIONS

(13 Periods)

Advanced cryptographic protocols: Selected Classic Ciphers and Cryptanalysis: World War II Ciphers. Selected Modern Ciphers and Cryptanalysis: Smart Card, Cellular and Wireless Communication Ciphers, Zero Knowledge Protocols, Secret Sharing Schemes. Protection in Operating Systems

E-commerce protocols/schemes: E-cash, micropayment, blind signature, Electronic voting, electronic auction, payment servers, fair exchange of signatures for contract signing, Data on move and Data on rest in World Wide Web.

UNIT-V: OVERVIEW OF RESOURCE CONSTRAINT NETWORKS

(10 Periods)

Sensor networks, wireless ad hoc networks, mobile ad hoc networks, radio frequency identification networks; Security issues in resource constraint networks: lightweight cryptography. Tag and ownership transfer protocols, Yoking/grouping protocols, designing integrated security architecture, McCumber Cube model, secure protocols for behavior enforcement, Game theoretic model of packet forwarding

Total Periods: 55

TEXT BOOKS:

1. Bruce Schneier, "Applied Cryptography," 2ed,Wiley India Pvt. Ltd ,New Delhi:, 2012.
- 2.L. Buttyan, J. P. Hubaux, "Security and Cooperation in Wireless Networks", Cambridge University Press, 2008.

REFERENCE BOOKS:

1. Wenbo Mao, "Modern Cryptography – Theory and Practice,",1ed, Pearson Education, New Delhi 2008.
2. James Kempf, "Wireless Internet Security: Architecture and Protocols", Cambridge University Press, 2008.

**M. Tech (CN&IS) II-Semester
(14MT26304) DESIGN OF SECURE PROTOCOLS
(ELECTIVE –II)**

Int. Marks	Ext. Marks	Total Marks	L	T	P	C
40	60	100	4	--	--	4

PRE-REQUISITES: A Course on "Cryptography and Network Security".

COURSE DESCRIPTION:

Pseudorandom Bit generation and algorithm modes; Symmetric and asymmetric cryptography; Authentication protocols and Hash functions; Security implementations

COURSE OUTCOMES:

On successful completion of this course the students will be able to:

- CO1. Gain advanced knowledge in
 - Pseudorandom Bits and Algorithm Modes.
 - Basic Cryptography Techniques.
 - Authentication Protocols.
 - One-way Hash Functions and Security Implementations in Real World.
- CO2. Analyze vulnerabilities in any computing system of the real world and identify the cryptographic solutions.
- CO3. Design and Develop Cryptographic protocol solutions for various Security Problems in real world
- CO4. Create and Select appropriate protocol solution for possible security threats in complex real time systems.

UNIT-I: PSEUDORANDOM BITS AND ALGORITHM MODES (Periods:12)

Introduction, Random Bit Generation, Pseudorandom Bit generation, Statistical Tests, Cryptographically Secure Pseudorandom Bit Generation, Linear Congruential Generators, Linear Feedback Shift Registers, Design and Analysis Of Stream Ciphers, Stream Ciphers Using LFSRs.

Algorithm Modes-Block Replay, Stream Ciphers, Self Synchronizing Stream Ciphers, Synchronous Stream Ciphers and Other Block Cipher, Choosing a Cipher Mode, Interleaving, Block Ciphers Versus Stream Ciphers.

UNIT-II: BASIC CRYPTOGRAPHY TECHNIQUES (Periods:12)

Symmetric Techniques-Definition, Substitution Ciphers, Transposition Ciphers, Classical Ciphers, AES, DES, Confidentiality Modes of Operation

Asymmetric Techniques-Introduction, Knapsack Algorithms, Diffie-Hellman Key Exchange Protocol, RSA Cryptosystem, RSA problem, Rabin Cryptosystem, Elgamal Cryptosystem, Security Notations for Public Key Cryptosystems, Combination of Symmetric and Asymmetric Cryptosystems, Key Channel Establishment for public Key Cryptosystem.

UNIT-III: AUTHENTICATION PROTOCOLS (Periods:14)

Basic Authentication Techniques, Password based Authentication; Authenticated Key Exchange Based on Asymmetric Cryptography, Typical Attacks on Authentication Protocols, SSH, Kerberos Protocol, SSL and TLS.

UNIT-IV: ONE-WAY HASH FUNCTIONS (Periods:12)

Background, Snefru, N-Hash, MD5, Secure Hash function (SHA), Ripe-MD, Haval, Other One-Way Hash Functions, One-Way Hash Function using Symmetric Block Algorithms, Using Public-Key Algorithms, Choosing a One-Way Hash Functions, Advanced Attacks on Hash Functions, Message Authentication Codes.

UNIT-V: SECURITY IMPLEMENTATIONS (No. of Periods: 08)

IBM Secret-Key Management Protocol, MITRENET, ISDN, STU-III, Kerberos, KryptoKnight, Sesame, Privacy-Enhanced Mail(PEM), PGP, Smart Cards, Public Key Cryptography Standards(PKCS), Universal Electronic Payment Systems(UEPS), Clipper, Capstone.

Total Periods:58

TEXTBOOKS:

1. Bruce Schneier, "*Applied Cryptography*," New Delhi: Wiley India Pvt. Ltd, Student Edition, Second Edition, 2012.
2. Wenbo Mao, "*Modern Cryptography – Theory and Practice*," New Delhi, Pearson Education, First Edition, 2008.

REFERENCE BOOKS:

1. Alfred Jimenez's, Paul C. Van Borscht, Scott A. Vanstone, "*Handbook of Applied Cryptography*," CRC Press, Special Indian Edition.
2. William Stallings, "*Cryptography and Network Security*," New Delhi: Pearson Education, Fifth Edition, 2003.
3. Atul Kahate, "*Cryptography and Network Security*," New Delhi: Tata McGraw Hill, Third Edition, 2013.

SREE VIDYANIKETHAN ENGINEERING COLLEGE (Autonomous)
Department of Computer Science and Engineering
I M. Tech (CN&IS) I-Semester
(16MT16302) ETHICAL HACKING
(Professional Elective – 1)

Int. Marks	Ext. Marks	Total Marks	L	T	P	C
40	60	100	4	-	--	4

PRE-REQUISITES:

Courses on "Computer networks, Cryptography & Network security"

COURSE DESCRIPTION:

Introduction to hacking concepts; Password hacking Techniques; Denial of service attacks; Web application vulnerabilities; Wireless hacking & physical security; overview of cryptography and penetration testing methodologies.

COURSE OUTCOMES:

After successful completion of this course, the students will be able to:

CO1: Gain Knowledge on

- Hacking and its societal issues
- Hacking methods
- Types of hacking
- Tools of hacking

CO2: Analyze system, network vulnerabilities which give a scope to perform hacking.

CO3: Develop skills to solve the different security risks that arise from hacking.

CO4: Design new techniques and tools to solve real world security problems.

CO5: Apply appropriate ethical hacking techniques to provide solution for a given security problem

CO6. Undertake research to solve security problems at host, data and Network level.

DETAILED SYLLABUS:

UNIT I :INTRODUCTION TO ETHICAL HACKING (11 Periods)

Introduction, Ethical hacking terminology, Types of hacking technologies, phases of ethical hacking, Foot printing, Social Engineering, Scanning and enumeration.

UNIT II: SYSTEM HACKING (11 Periods)

Understanding the password hacking techniques, Rootkits, Trojans, Backdoors, Viruses and worms, sniffers.

UNIT III: DENIAL OF SERVICE &WEB SERVER HACKING

(11 Periods)

Denial of service, session hijacking, Hacking web servers, Web application vulnerability, web application vulnerabilities ,SQL Injection, Buffer overflow.

UNIT IV: WIRELESS HACKING & PHYSICAL SECURITY

(11 Periods)

WEP, WPA Authentication mechanism-wireless sniffers-Physical Security-factors affecting physical security-honeypots-Firewall types

UNIT V: PENETRATION TESTING (11 Periods)

Cryptography-overview of MD5, SHA, RC4, Penetration testing methodologies- Defining security assessment, overview, steps, pen test legal framework, penetration testing tools.

Total Periods: 55

TEXT BOOK:

1. *Kimberly graves "CEH Official Certified Ethical Hacker Review Guide,"* Wiley publications, 2007

REFERENCE BOOKS:

1. Micheal Gregg, "*Certified ethical hacker (CEH) Cert guide*", Pearson education, 2014.
2. Patrick Engebretson, "*The Basics of Hacking and Penetration Testing: Ethical Hacking and Penetration Testing Made Easy*", 2ed, Syngress Media, 2012.

SREE VIDYANIKETHAN ENGINEERING COLLEGE (Autonomous)
Department of Computer Science and Engineering

I M. Tech (CN&IS) I-Semester
(16MT10507) INTERNET OF THINGS
(Professional Elective-1)
(Common to CS and CNIS)

Int. Marks	Ext. Marks	Total Marks	L	T	P	C
40	60	100	4	-	--	4

PRE-REQUISITES:

Courses on "Computer Networks" and "Java"

COURSE DESCRIPTION:

Domain Specific IoT's; M2M& System Management with Netconf-Yang; Developing Internet of Things Using Python; IoT Physical Devices & Case Studies Illustrating IoT Design

COURSE OUTCOMES:

After successful completion of this course, the students will be able to:

CO1: Gain knowledge on

- o Building blocks of Internet of Things and characteristics.
- o Application areas of IoT
- o Concept of M2M (machine to machine) with necessary protocols

CO2: Analyze Domain specific IoT's, revolution of Internet in Mobile Devices.

CO3: Design and Develop Techniques for solutions to solve the problems in IoT using Python Scripting Language.

CO4: Conduct research on domain specific IoT's and IoT enabling Technologies.

CO5: Acquire knowledge to recognize the opportunities and contribute to collaborative-multidisciplinary Scientific Research.

DETAILED SYLLABUS:

UNIT I: INTRODUCTION & CONCEPTS (08 periods)

Introduction to Internet of Things –Definition and Characteristics of IoT, Physical Design of IoT – IoT Protocols, Logical Design of IOT, IOT Enabling Technologies, IoT Levels and Templates

UNITII: DOMAIN SPECIFIC IOTS (09 periods)

Home Automation, Cities, Environment, Energy, Retail, Logistics, Agriculture, Industry, Health & Life Style

UNITIII: M2M & SYSTEM MANAGEMENT WITH NETCONF-YANG (11 periods)

IoT and M2M – M2M, Difference between IOT and M2M, difference between SDN and NFV for IoT, Software defined networks, network function virtualization, Need for IOT Systems Management, Simple Network Management Protocol, Limitations of SNMP, Network Operator Requirements.

Basics of IoT System Management with NETCOZF, YANG, YANG-NETCONF

UNITIV: DEVELOPING INTERNET OF THINGSUSING PYTHON

(15 periods)

Introduction, IOT Design Methodology, Installing Python, Language features of Python, Python Data Types & Data Structures, Control Flow, Functions, Modules, File Handling, Date/ Time Operations, Classes, Exception handling, Python Packages of Interest for IoT.

UNIT V: IOT PHYSICAL DEVICES & ENDPOINTS (12 periods)

What is an IOT Device, Exemplary Device, Board, Linux on Raspberry Pi, Interfaces, Programming and IOT Devices, Case Studies Illustrating IoT Design: Home Automation, Cities and Agriculture.

Total Periods: 55

TEXT BOOK:

1. Vijay Madiseti, Arshdeep Bahga," *Internet of Things A Hands-On Approach*", University Press, 2015.

REFERENCE BOOKS:

1. Adrian McEwen, "*Designing the Internet of Things*", Wiley Publishers, 2014.
2. Daniel Kellmerit, "*The Silent Intelligence: The Internet of Things*", 2013, DND Ventures LLC, 2013.

SREE VIDYANIKETHAN ENGINEERING COLLEGE (Autonomous)
Department of Computer Science and Engineering
I M. Tech. (CN&IS) I-Semester
(16MT16331) COMPUTER NETWORKS & INFORMATION
SECURITY LAB

Int. Marks	Ext. Marks	Total Marks	L	T	P	C
50	50	100	--	--	4	2

PRE-REQUISITES:

Courses on "Computer Networks" and "Information Security"

COURSE DESCRIPTION:

Hands experience on Data Link Layer Framing Methods; Routing Algorithms; Implementation of DES, RSA; AES Algorithms, Secure Hash Algorithms and Digital Signature Standards.

COURSE OUTCOMES:

After successful completion of this course, the students will be able to:

CO1. Gain knowledge to implement

- Framing mechanisms for data link layer
- Shortest path routing algorithms
- Symmetric encryption algorithms- DES,AES and Asymmetric algorithm-RSA
- Secure Hash algorithms and digital signatures

CO2. Analyze the routing algorithms, Symmetric-key encryption and public-key encryption algorithms.

CO3. Develop the solutions to solve the problems in networks and information security systems.

CO4. Implement routing and encryption techniques using C or JAVA to provide solutions to the real world problems.

Laboratory Exercises:

Exercise Number.	Name of Experiment	No. of slots
1	Implement the following data link layer framing methods. a. Character Count b. Character Stuffing c. Bit Stuffing	1
2	Design a program to compute checksum for the given frame 1101011011 using CRC-12, CRC-16, CRC-CCIP. Display the actual bit string transmitted. Suppose any bit from is inverted during transmission. Show that this error is detected at the receivers end.	1

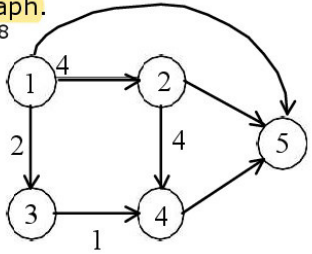
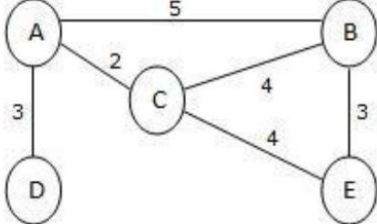
3	<p>Implement Dijkstra's algorithm to compute the Shortest path through a graph.</p> 	1
4	<p>Design a program to obtain routing table for each node using distance vector routing algorithm by considering the given subnet with weights indicating delay between nodes.</p> 	1
5	Write a program to simulate flow based routing	1
6	Simulate the Random Early Detection congestion control algorithm	1
7	Write a program to encrypt and decrypt given text using DES symmetric key algorithm	1
8	Write a program to encrypt and decrypt given text in public key cryptographic system using RSA	1
9	Write a program to encrypt and decrypt given text using AES algorithm with 128-bit key	1
10	Write a program to generate a Hash code for the given text using SHA-512 algorithm	1
11	Create a digital signature for the given doc/pdf file using DSS algorithm	1
12	Configure Firewall filters to accept/reject URLs/web content	1

REFERENCE BOOKS:

1. William Stallings, "Network Security Essentials: Applications and Standards," 4ed, New Delhi, Pearson Education, 2011
2. Nader F. Mir, "Computer and Communication Networks," Pearson Education, 2007
3. Eric Maiwald, "Fundamentals of Network Security", 4ed, Tata McGraw Hill, 2003

**M. Tech. (CN & IS) - I Semester
(14MT16321) WIRELESS NETWORKS & INFORMATION
SECURITY LAB**

Int. Marks	Ext. Marks	Total Marks	L	T	P	C
25	50	75	--	--	4	2

PRE-REQUISITES: Courses on “Wireless Networks” and “Information Security”

COURSE DESCRIPTION:

Develop programs for simulating wired and wireless computer network protocols and implement using network simulation tools.

Design and implement programs for Information security algorithms DES, RSA, AES, SHA and DSS using network simulators.

COURSE OUTCOMES:

On successful completion of this course the students will be able to:

CO1. Design wireless networking models and validate new protocols.

CO2. Analyze the typical performance measures of network models.

CO3. Compare and contrast various performance measures of different network models.

CO4. Develop new simulation models of protocols and mechanisms

List of Exercises in Wireless Networks:

(Total no. of Lab exercises to be performed: 05)

1. Simulate TCP-SACK (Selective Acknowledgement Protocol) Protocol for Wireless Networks
2. Simulate Pure ALOHA Protocol and Slotted ALOHA Protocol.
3. Simulate Carrier Sense Multiple Access (CSMA) Protocol.
4. Simulate Destination Sequenced Distance Vector (DSDV) Routing Algorithm for AdHoc Networks.
5. Simulate Ad Hoc on Demand Distance Vector (AODV) Routing Algorithm for AdHoc Networks.

List of Exercises in Information Security:

(Total no. of Laboratory exercises to be performed: 07)

1. Write a program to encrypt and decrypt given text using DES symmetric key algorithm.
2. Write a program to encrypt and decrypt given text in public key cryptographic system using RSA.
3. Write a program to encrypt and decrypt given text using AES algorithm with 128-bit key.
4. Write a program to implement port monitoring using NMAP.
5. Write a program to generate a Hash code for the given text using SHA-512 algorithm.
6. Create a digital signature for the given doc/pdf file using DSS algorithm.
7. Configure Firewall filters to accept/reject URLs/web content.

SREE VIDYANIKETHAN ENGINEERING COLLEGE (Autonomous)
Department of Computer Science and Engineering
M. Tech (CN&IS) I-Semester
(16MT16332) WEB TECHNOLOGIES LAB

Int. Marks	Ext. Marks	Total Marks	L	T	P	C
50	50	100	-	-	4	2

PRE-REQUISITES:

Course on "Programming in C, and Java"

COURSE DESCRIPTION:

This course is hands-on and project-based; students will construct a substantial dynamic web application based on the concepts, technologies, and techniques presented during lecture.

COURSE OUTCOMES:

After completion of this course the students will be able to:

- CO1. Gain knowledge in designing web pages using HTML, CSS, JS, PHP.
- CO 2. Analyze the design problems in HTML Web pages with CSS
- CO3. Design a dynamic webpage with HTML, CSS, Java Script, PHP concepts
- CO4. Assess the HTML Website using XML Parsers
- CO 5. Engage in lifelong learning by incorporating the best design practices.

LIST OF EXERCISES:

Exercise number.	Name of the Exercise	No. of Slots required
1.	Create an HTML web page with at least the following features: Keywords & description meta tags, title, Page formatting, including a background color <i>and</i> picture, a non-default text color, and non-default text and link colors, A horizontal rule, At least three levels of headers, Text formatting, including specifying a non-default font as well as centered, bold, italics, subscript, superscript, and strikethrough, A three-level bulleted list and a two-level numbered list, At least two external links, with one a text link and one an image link, Three internal "bookmark" links – that is, a link to further down on the current page, A relative link to an image in a different directory than the directory in which your current HTML page resides, An image with a non-standard-width border in a non-standard color. The image should appear off to the right side of the page, An image map with at least three links, A table that includes at least three rows, two cells in each row, two	1

	colspan attributes, and one rowspan attribute. Put a background color on the entire table, a different background color on one cell, and a background image on one entire row of the table.	
2.	Develop static pages (using only HTML) of an online Book store. The pages should resemble: www.amazon.com . The website should consist of the following pages. <ul style="list-style-type: none"> • Books catalogue • Shopping cart • Payment by credit card • Order Conformation 	1
3.	Design a web page using CSS which includes the following: <ol style="list-style-type: none"> 1) Use different font styles 2) Set background image for both the page and single elements on page. 3) Control the repetition of image with background-repeat property 4) Define style for links as a:link, a:active, a:hover, a:visited 5) Add customized cursors for links. 6) Work with layers 	1
4.	Create an HTML web page with JavaScript for the following problem: Get two input numbers from an HTML form. On submit, call a function to edit them to make sure that they are within the range of 1-100. If not, display an error message and set focus to the field in error. If the entered numbers are valid, add the two numbers together and display the total in an alert box. Pop up a prompt box to get a third number and edit it to make sure it's in the range of 1 to 5. Multiply the original total (from the two input boxes) by this third number. Store the result in a cookie and then automatically open a second page to display the cookie that you saved on the prior page.	1
5.	Validate the registration, user login, user profile and payment by credit card pages using JavaScript.	1
6.	a. Write an XML file which will display the Book information which includes the following: <ol style="list-style-type: none"> 1) Title of the book 2) Author Name 3) ISBN number 4) Publisher name 5) Edition 6) Price 	1

7.	b. Write a Document Type Definition (DTD) to validate the above XML file. Display the XML file as follows: The contents should be displayed in a table. The header of the table should be in color GREY. And the Author names column should be displayed in one color and should be capitalized and in bold. Use your own colors for remaining columns. Use XML schemas XSL and CSS for the above purpose. Note: Give at least for 4 books. It should be valid syntactically. Hint: You can use some xml editors like XML-spy	1
8	Write PHP Script to demonstrate a. String processing in PHP b. File uploading	1
9	Write PHP Script to demonstrate Sessions and Cookies	1
10	Write a PHP which inserts the details of the 3 or 4 users who register with the web site by using registration form. Authenticate the user when he submits the login form using the user name and password from the database	1
11	Write a PHP which does the following job: Insert the details of the 3 or 4 users who register with the web site by using registration form. Authenticate the user when he submits the login form using the user name and password from the database	1

REFERENCE BOOKS:

1. Chris Bates, *"Web Programming: Building Internet Applications,"* 3ed, Wiley India Pvt. Ltd., New Delhi, 2009.
2. W Jason Gilmore, *"Beginning PHP and MySQL: From Novice to Professional,"* 4ed, New Delhi, India: Springer India Pvt. Ltd., 2011.

**M. Tech (CN&IS) II-Semester
(14MT26322) WEB PROGRAMMING AND CLOUD COMPUTING
LABORATORY**

Int. Marks	Ext. Marks	Total Marks	L	T	P	C
25	50	75	-	-	4	2

PRE-REQUISITES: Courses on “Web Programming” and “Cloud Computing”

COURSE DESCRIPTION:

Develop and implement dynamic web applications on contemporary and social issues using HTML, CSS, JS and PHP technologies.

Hands on practice in using Visual Modeling Tools and design real time case studies such as Automated Teller Machine (ATM), Online Ticket Reservation for Railways, A Point-of-Sale (POS) System, A Multi-Threaded Airport Simulation, Hospital Management System, Unified Library Application, and Online Shopping.

COURSE OUTCOMES:

On successful completion of this course the students will be able to:

- CO1. Gain Knowledge on the real time applications of Cloud computing and to design web pages using HTML, CSS and JS.
- CO2. Analyze XML files using DTD parser.
- CO3. Use Dreamweaver and Notepad++ for designing web pages and generating dynamic content. And Cloud Computing tools Windows Azure, Sales Force, and VMware
- CO4. Recognize the need of Cloud Computing, Software Testing and can engage in lifelong learning by incorporating best practices of them
- CO5. Develop websites for self-development and for promoting awareness among the community in societal and environmental issues.

Laboratory Exercises:

Web Programming:

1. Create an HTML web page with at least the following features:
Keywords & description meta tags, title, Page formatting, including a background color *and* picture, a non-default text color, and non-default text and link colors, A horizontal rule, At least three levels of headers, Text formatting, including specifying a non-default font as well as centered, bold, italics, subscript, superscript, and strikethrough, A three-level bulleted list and a two-level numbered list, At least two external links, with one a text link and one an image link, Three internal “bookmark” links – that is, a link to further down on the current page, A relative link to an image in a different directory than the directory in which your current HTML page resides, An image with a non-standard-width border in a non-standard color. The image should appear off to the right side of the page, An image map with at least three links, A table that includes at least three rows, two cells in each row, two colspan attributes, and one rowspan attribute. Put a background color on the entire table, a different

background color on one cell, and a background image on one entire row of the table.

2. Create an HTML web page with JavaScript for the following problem:
Get two input numbers from an HTML form. On submit, call a function to edit them to make sure that they are within the range of 1-100. If not, display an error message and set focus to the field in error. If the entered numbers are valid, add the two numbers together and display the total in an alert box. Pop up a prompt box to get a third number and edit it to make sure it's in the range of 1 to 5. Multiply the original total (from the two input boxes) by this third number. Store the result in a cookie and then automatically open a second page to display the cookie that you saved on the prior page.
3.
 - a. Write an XML file which will display the Book information which includes the following:
 - 1) Title of the book
 - 2) Author Name
 - 3) ISBN number
 - 4) Publisher name
 - 5) Edition
 - 6) Price
 - b. Write a Document Type Definition (DTD) to validate the above XML file. Display the XML file as follows:
The contents should be displayed in a table. The header of the table should be in color GREY. And the Author names column should be displayed in one color and should be capitalized and in bold. Use your own colors for remaining columns. Use XML schemas XSL and CSS for the above purpose. Note: Give at least for 4 books. It should be valid syntactically. Hint: You can use some xml editors like XML-spy
4. Write PHP Script to demonstrate
 - a. String processing in PHP
 - b. File uploading
 - c. Sessions and Cookies
5. Write PHP Script that takes user input data(Personal Information like registration to a website) in a form and validates it and write the data into the database

Sales Force:

6. Using Salesforce CRM,
 - a. Create a Warehouse Application.
 - b. Add Relationships to it.
 - c. Apply formulas and Validation Rules on the records of a data.
 - d. Creation of Dash Boards.
 - e. Create an approval process for it and generate reports.

MS-Azure:

7. Create and Configure Virtual Machines using MS-Azure.
8. Create and configure SQL server in an Azure VM
9. Web hosting using MS-Azure.

VMware:

10. Illustrate forms of virtualization on VMware.

SREE VIDYANIKETHAN ENGINEERING COLLEGE (Autonomous)
Department of Computer Science and Engineering
I M. Tech (CN&IS) II-Semester
(16MT20502) BIG DATA ANALYTICS
(Common to CS & CNIS)

Int. Marks	Ext. Marks	Total Marks	L	T	P	C
40	60	100	4	--	--	4

PRE-REQUISITES:

Courses on "Data Base Management Systems" & "Data Warehousing and Data Mining"

COURSE DESCRIPTION:

Concepts of Big Data; Types of Data Elements; Introduction to Hadoop; Hadoop Ecosystems; MapReduce; Building Blocks of Hadoop; big data analytics applications; Predictive and Descriptive Analytics.

COURSE OUTCOMES:

After successful completion of this course, the student will be able to:

CO1. Demonstrate in depth knowledge in

- Big data Characteristics
- Hadoop Framework
- MapReduce.
- Hadoop Release

CO2. Analyze and develop solutions for database systems for storing and analyzing the large data.

CO3. Apply Big Data Analytics for estimating the data sets to solve the real world problems

CO4. Design and model for an effective database by using big data tools.

CO5. Carry out research on predictive analysis and sentiment analysis.

CO5. Learning advance analytics techniques for effective Database monitoring.

DETAILED SYLLABUS:

UNIT I- Introduction to Big data: (10 periods)

Big Data Characteristics: Volume-Variety-Velocity-Veracity, Analytics, Basic Nomenclature, Analytics Process Model, Analytical Model Requirements, Types of Data Sources, Sampling, Types of Data Elements, Missing Values, Standardizing Data, Outlier Detection and Treatment, Categorization.

UNIT II -Introduction to Hadoop: (10 periods)

Data, data types, Storage and Analysis, Relational Database Management Systems, Grid Computing, Volunteer Computing, A Brief History of Hadoop, Apache Hadoop and the Hadoop Ecosystem.

UNIT III – MapReduce: (11 periods)

A weather Dataset: Data format, Analyzing the data with Unix tools, Analyzing the data with Hadoop: MapReduce, Java MapReduce, Scaling Out: Data Flow, Combiner Functions, Running a Distributed MapReduce Job, Hadoop Streaming: Ruby, Python, Hadoop Pipes, Compiling and Running.

UNIT IV – Hadoop Releases: (11 Periods)

The Building Blocks of Hadoop: Name Node-Data Node-Secondary Name Node-Job Tracker-Task Tracker.

BIG DATA ANALYTICS APPLICATIONS: Back Testing Analytical Model, Credit Risk Modeling, Fraud Detection, Net Lift Response, Web Analytics, Social Media Analytics, and Business Process Analytics.

UNITV–PREDICTIVE ANALYTICS AND DESCRIPTIVE ANALYTICS (11 Periods)

Predictive Analytics: Target Definition, Linear Regression, Logistic Regression, Decision Trees, Support Vector Machines, Ensemble Methods, Multiclass Classification Techniques, Evaluating Predictive Models.

Descriptive Analytics: Association Rules, Sequence Rules.

Total No. of Periods: 53

TEXT BOOKS:

1. Bart Baesens, *"Analytics in a Big Data World: The Essential Guide to Data Science and its Applications,"* Wiley Publications, 2014.
2. Tom White, *"Hadoop: The Definitive Guide,"* 3ed, O'REILLY Publications, 2012.

REFERENCE BOOKS:

1. Paul Zikopoulos, IBM, Chris Eaton, Paul Zikopoulos *"Understanding Big Data: Analytics for Enterprise Class Hadoop and streaming Data,"* The McGraw-Hill Companies, 2012.
2. Chuck Lam, *"Hadoop in Action,"* Manning Publications, 2011.

**M. Tech (CN&IS) II-Semester
(14MT20506) BIG DATA ANALYTICS (Elective-II)**

Int. Marks	Ext. Marks	Total Marks	L	T	P	C
40	60	100	4	--	--	4

PRE-REQUISITE: A Course on "Data warehousing and Mining".

COURSE DESCRIPTION:

Data Science and Analytics; unsupervised learning; big data from business perspective; Hadoop Technology and application development, Management, InfoSphere big insights and InfoSphere streams

COURSE OUTCOMES:

On successful completion of this course the students will be able to:

- CO1. To gain knowledge about the
 - Data Science and Unsupervised Learning.
 - Big data Characteristics and Methods.
 - InfoSphere Big insights and Streams.
- CO2. To analyze the need for database systems for storing the large data
- CO3. To design and model an effective and sustainable database for better performance using big data tools.
- CO4. To use Hadoop tools and Methodologies for modeling large databases and real time applications

UNIT I - INTRODUCTION TO DATA SCIENCE (Periods:11)

Introduction- Introduction of Data Science, Getting started with R- Exploratory Data Analysis, Review of probability and probability distributions, Bayes Rule Supervised Learning, Regression, polynomial regression, local regression and k-nearest neighbors

UNIT II - UNSUPERVISED LEARNING (Periods:12)

Unsupervised Learning- Kernel density estimation, k-means, Naive Bayes, Data and Data Scraping Classification, ranking, logistic regression, Ethics, time series advanced regression, Decision trees, Best practices and feature selection.

UNIT III - BIG DATA FROM DIFFERENT PERSPECTIVES (Periods:11)

Big data from business Perspective-Introduction of big data, Characteristics of big data, Data in the warehouse and data in Hadoop, Importance of Big data, Big data Use cases, Patterns for Big data deployment. Big data from Technology Perspective, History of Hadoop, Components of Hadoop, Application Development in Hadoop, Getting your data in Hadoop, other Hadoop Component

UNIT IV - INFOSPHERE BIG INSIGHTS (Periods:11)

InfoSphere Big Insights-Analytics for Big data at rest, A Hadoop ready Enterprise, Quality file system, Compression, Administrative tooling, Security Enterprise Integration, Improved workload scheduling, Adaptive map reduce, Data discovery and visualization and Machine Analytics.

UNIT V- INFOSPHERE STREAMS**(Periods:10)**

InfoSphere Streams-Analytics for Big data in motion, InfoSphere Streams Basics working of InfoSphere Streams, Stream processing language, Operators, Stream toolkit, Enterprise class.

Total Periods:55**TEXT BOOKS:**

1. Noreen Burlingame and Lars Nielsen, "A Simple Introduction to Data Science," New Street Communications, LLC, Wickford, Rhode Island, 2012
2. Paul Zikopoulos and Chris Eaton, "Understanding Big Data: Analytics for Enterprise Class Hadoop and streaming Data," The McGraw-Hill Companies, 2012.

REFERENCE BOOKS:

1. Anand Rajaraman and Jeffrey David Ullman, "Mining of Massive Datasets", Cambridge University Press, 2012
2. Bill Franks, "Taming the Big Data Tidal Wave: Finding Opportunities in Huge Data Streams with Advanced Analytics", John Wiley & sons, 2012.

SREE VIDYANIKETHAN ENGINEERING COLLEGE (Autonomous)
Department of Computer Science and Engineering
I M.Tech. (CNIS) II Semester
(16MT12501) CLOUD COMPUTING
(Common to SE, CS & CNIS)

Int. Marks	Ext. Marks	Total Marks	L	T	P	C
40	60	100	4	-	-	4

PREREQUISITES:

Courses on "Operating Systems" and "Computer Networks"

COURSE DESCRIPTION:

Virtualization, Case studies – XEN, VMware, Microsoft Hyper-V; Cloud architecture; Services and Applications; Cloud Programming; Industry practices and Case studies –Amazon Web Services, Google App Engine, and Microsoft Azure.

COURSE OUTCOMES:

After successful completion of this course, students will be able to:

- CO1: Demonstrate knowledge on Virtualization models, Cloud Architecture, Services and Programming concepts.
- CO2: Analyze the problems in existing cloud architectures.
- CO3: Apply concurrent programming, throughput computing and Data intensive computing in Cloud programming.
- CO4: Conduct research on emerging technologies in cloud and energy management in cloud
- CO5: Apply virtualization techniques to optimize resource sharing.

DETAILED SYLLABUS:

Unit I: INTRODUCTION TO VIRTUALIZATION (9 Periods)

Characteristics of Virtualized Environments, Taxonomy of Virtualization Techniques, Virtualization and Cloud Computing, Pros and Cons of Virtualization, Technology Examples – XEN, VMware, Microsoft Hyper-V.

UNIT II: CLOUD ARCHITECTURE (11 Periods)

Introduction to Cloud: Defining Cloud Computing, Cloud Types - The NIST model, The Cloud Cube Model, Deployment models, Service models, Examining the Characteristics of Cloud Computing, Paradigm shift, Benefits of cloud computing, Disadvantages of cloud computing, Assessing the Role of Open Standards.

Cloud Architecture: Exploring the Cloud Computing Stack, Composability, Infrastructure, Platforms, Virtual Appliances, Communication Protocols, and Applications.

UNIT III: DEFINING CLOUD SERVICES (10 Periods)

Defining Infrastructure as a Service (IaaS) – IaaS workloads, Pods, aggregation, and silos, **Defining Platform as a Service (PaaS), Defining Software as a Service (SaaS)** – SaaS characteristics, Open SaaS and SOA, Salesforce.com and CRM SaaS, **Defining Identity as a Service (IDaaS)** – Introduction to identity,

Networked identity service classes, Identity system codes of conduct, IDaaS interoperability, **Defining Compliance as a Service (CaaS)**.

UNIT IV: CLOUD PROGRAMMING CONCEPTS (12 Periods)

Concurrent Programming – Introduction to Parallelism for Single Machine Computation, Programming Applications with Threads, **High Throughput Computing** – Task Programming, Task based Application Models, **Data Intensive Computing** – Introduction to Data Intensive Computing and Technologies for Data Intensive Computing.

UNIT V: INDUSTRIAL PLATFORMS AND TRENDING DEVELOPMENTS (13 Periods)

Case Studies on Cloud Platforms – Amazon Web Services, Google App Engine, and Microsoft Azure, Case Studies on Cloud Applications – Scientific Applications, Business and Consumer Applications.

Enhancements in Cloud – Energy Efficiency in Clouds, Market based Management of Clouds, Federated Clouds / InterCloud, **Third Party Cloud Services**.

Total Periods: 55

TEXT BOOKS:

1. Rajkumar Buyya, Christian Vecchiola, and S. Thamarai Selvi, "Mastering Cloud Computing: Foundations and Applications Programming," 1ed, McGraw Hill, New Delhi, 2013.
2. Barrie Sosinsky, "Cloud Computing Bible," 1ed, Wiley India Pvt Ltd, New Delhi, 2011.

REFERENCE BOOKS:

1. Toby J. Velte , Anthony T. Velte, and Robert Elsenpeter, "Cloud Computing: A Practical Approach," 1ed, Tata McGraw Hill, 2010.
2. George Reese, "Cloud Application Architectures," 1ed, O'Reilly Publishers, 2010.

**M. Tech (CN&IS) II-Semester
(14MT20509) VIRTUALIZATION AND CLOUD COMPUTING**

Int. Marks	Ext. Marks	Total Marks	L	T	P	C
40	60	100	4	--	--	4

PRE-REQUISITES: *Courses on "Distributed Computing" and "Computer Networks"*

COURSE DESCRIPTION:

Introduction to Cloud Computing and virtualization; Map reduce programming; Cloud technologies – Amazon web services, Google App Engine, and Microsoft Azure; Scientific and business applications of Cloud

COURSE OUTCOMES:

On successful completion of this course the students will be able to:

- CO1. Gain Knowledge on the technical foundations of Cloud technology.
- CO2. Analyze the Cloud Architectures while developing the internet web applications.
- CO3. Solve security issues in cloud applications.
- CO4. Get exposure to cloud tools like Microsoft Azure, Google App Engine, and Amazon Web Services.

UNIT- I: VIRTUALIZATION

(Periods:13)

VIRTUALIZATION-Introduction to virtualization , Objectives of virtualization, history of virtualization, benefits of virtualized technology, the virtual service desk, related forms of computing, Understanding Hypervisors, Load balancing & Virtualization. Virtualization and Cloud Computing, Pros and Cons of Virtualization, Technology Examples-Xen, Para virtualization, VMware, Full Virtualization, Microsoft Hyper-V.

UNIT-II: CLOUD COMPUTING OVERVIEW

(Periods:12)

CLOUD COMPUTING OVERVIEW- Cloud computing at a Glance, The Vision of Cloud Computing, Defining a Cloud, A Closer Look, Cloud Computing Reference Model, Characteristics and Benefits, Pros and Cons of cloud, Challenges Ahead; Historical Developments, Building Cloud Computing Environments, Computing Platforms and Technologies

CLOUD COMPUTING ARCHITECTURE-Cloud Reference Model, Types of Clouds, Economics of the Cloud, Open Challenges.

UNIT- III: DATA INTENSIVE COMPUTING: MAP-REDUCE PROGRAMMING

(Periods:10)

Data-Intensive Computing, Technologies for Data-Intensive Computing, Aneka Map Reduce Programming.

UNIT-IV: CLOUD TECHNOLOGIES

(Periods:10)

Amazon Web Services-Compute Services, Storage Services, Communication Services, Additional Services, **Google AppEngine** -Architecture and Core Concepts, Application Life-Cycle, **Microsoft Azure**-Azure Core Concepts, SQL Azure, Windows Azure Platform Appliance.

UNIT-V: CLOUD APPLICATIONS**(Periods:13)**

Scientific Applications, Business and Consumer Applications

ADVANCED TOPICS IN CLOUD COMPUTING-Energy Efficiency in Clouds,
Market Based Management of Clouds, InterCloud.**Total Periods: 58****TEXT BOOKS:**

1. Raj Kumar Buyya, Christian Vecchiola, S.Thamarai Selvi, "*Mastering Cloud Computing*," Tata McGraw Hill ,New Delhi,2013
2. Ivanka Menken, Gerard Blokdiik, "*Cloud Computing Specialist Certification Kit – Virtualization, The Art of Service*," Emereo Pty Ltd, 2009

REFERENCE BOOKS:

1. Michael Miller, "*Cloud Computing: Web-Based Applications That Change the Way You Work and Collaborate Online*," Que Publishing, Pearson, August 2011.
2. George Reese, "*Cloud Application Architectures Building Applications and Infrastructure in the Cloud*," O'Reilly Media Released, April 2009.
3. Gautham Shroff, "*Enterprise Cloud Computing: Technology, Architecture, Application*," Cambridge University Press, 2010.
4. Barrie Sosinky, "*Cloud Computing Bible*", Wiley Publishing Inc, 2011.

SREE VIDYANIKETHAN ENGINEERING COLLEGE (Autonomous)

Department of Computer Science and Engineering

I M. Tech (CN&IS) II-Semester

(16MT26301) INTRUSION DETECTION SYSTEMS

Int. Marks	Ext. Marks	Total Marks	L	T	P	C
40	60	100	4	--	--	4

PRE-REQUISITES:

Courses on "Computer Networks" and "Network security"

COURSE DESCRIPTION:

Introduction to threats , attacks and intrusions; Network security monitoring and Sinkhole design; Traffic threat assessment and network incident response; Malicious bots and botnet construction; introduction to network forensics and Intrusion prevention systems(IPS) in host and network level.

COURSE OUTCOMES:

After successful completion of this course, students will be able to:

CO1: Gain Knowledge on Intrusions, security monitoring, Network Forensic principles and Intrusion Prevention system (IPS).

CO2: Analyze the threats and vulnerabilities in the network traffic for designing the solutions.

CO3: Detect, identify and mitigate the security attacks from the network traffic to provide the solutions to the real word problems.

CO4: Conduct research to identify novel solutions for detecting and mitigation of Intrusions in public and private networks.

CO5: Gain exposure on IDS and IPs tools of Intrusion and Extrusion detection for NSM data collections.

DETAILED SYLLABUS:

UNIT I: NETWORK SECURITY MONITORING REVISITED AND EXTRUSION DETECTION ILLUSTRATED (12 periods)

Network Security Monitoring Revisited: Defining the security process, Principles, Network security monitoring (NSM) Theory, Techniques and tools. Defensible Network Architecture- Defensible network Monitoring, Controlling, Minimizing and current.

Extrusion Detection Illustrated: Definition of Intrusion detection, Definition of Extrusion detection, History of Extrusion detection and Extrusion detection through NSM

UNIT II LAYER-3 NETWORK ACCESS CONTROL AND TRAFFIC THREAT ASSESSMENT (10 periods)

Layer-3 Network Access Control: Internal network Design, ISP sink holes, Enterprise sink holes and Internal intrusion containment.

Traffic Threat Assessment: Assumptions, First cuts, looking for odd traffic, Inspecting individual services through NTP, ISAKMP, ICMP, Secure shell, WhoIs, LDAP, other ports.

UNIT III : NETWORK INCIDENT RESPONSE AND NETWORK FORENSICS (11 periods)

Network Incident Response: Preparation for network incident response, Secure CSIRT communication, Intruder Profiles, Incident Detection Methods, Network First Response, Network-Centric General Response and Remediation.

Collecting network traffic as evidence, protecting and preserving network based evidence, Analyzing network based evidence, presenting and defending conclusions.

UNIT IV : MALICIOUS BOTS AND INTRUSION PREVENTION OVERVIEW (11 periods)

Traffic Threat Assessment Case Study, Malicious Bots: IRC bots, communication and identification, server and control channels, exploitation and bot admin.

Intrusion Prevention Overview, Signatures and Actions: Types, Triggers and actions, Operational Tasks: deploying & configuring IPS devices and applications, Monitoring IPS activities, Securing IPS communications

UNIT V: HOST INTRUSION PREVENTION AND NETWORK INTRUSION PREVENTION (11 periods)

Host Intrusion Prevention Overview, Capabilities, Benefits, Limitations, HIPS Components: End agents, Gathering data about the operation, state, security policy and Infrastructure.

Network Intrusion Prevention Overview, Capabilities, Benefits, Limitations, NIPS Components: Capturing, Analyzing, Responding to Network Traffic, Sensor management and Monitoring.

Total Periods: 55

TEXT BOOKS:

1. Richard Bejtlich, *"Extrusion Detection: Security Monitoring for Internal Intrusions,"* 1ed. Pearson Education, New Delhi, 2004.
2. Earl Carter, Jonathan Hogue, *"Intrusion Prevention Fundamentals,"* 1ed, Pearson Education, New Delhi, 2002.

REFERENCE BOOKS:

1. Carl Endorf, Eugene Schultz and Jim Mellander, *"Intrusion Detection and Prevention,"* McGraw-Hill, 2004
2. Stephen Northcutt, Judy Novak, *"Network Intrusion Detection,"* New Riders Publishing, 3ed, 2002

**M. Tech (CN&IS) II-Semester
(14MT26303) INTRUSION DETECTION SYSTEMS**

Int. Marks	Ext. Marks	Total Marks	L	T	P	C
40	60	100	4	--	--	4

PRE-REQUISITES: Courses on "Computer Networks" and "Network security"

COURSE DESCRIPTION:

Network security monitoring and intrusion detection systems; Enterprise network Instrumentation; Traffic threat assessment and Network incident response; Network forensics; Intrusion prevention

COURSE OUTCOMES:

On successful completion of this course the students will be able to:

- CO1. Gain Knowledge on Intrusion detection systems, security monitoring, Network Forensics principles and Intrusion Prevention system (IPS).
- CO2. Analyze, detect, identify and mitigate the security attacks from the network traffic.
- CO3. Get exposure to IDS and IPS security tools in network security devices.

UNIT-I: NETWORK SECURITY MONITORING REVISITED AND EXTRUSION DETECTION ILLUSTRATED (Periods:12)

Network Security Monitoring Revisited: Defining the security process, Principles, Network security monitoring (NSM) Theory, Techniques and tools. Defensible Network Architecture- Defensible network Monitoring, Controlling, Minimizing and current.

Extrusion Detection Illustrated: Intrusion detection defined, Extrusion detection defined, History of Extrusion detection and Extrusion detection through NSM.

UNIT-II: ENTERPRISE NETWORK INSTRUMENTATION AND LAYER-3 NETWORK ACCESS CONTROL (Periods:10)

Enterprise Network Instrumentation: Common Packet Capture Methods, PCI Tap, Dual port aggregator Tap, Regenerations and SPAN regeneration taps, Matrix switch, Link Aggregator Tap, Distributed traffic collection with PF Dup-To.

Layer 3 Network Access Control: Internal network Design, ISP sink holes, Enterprise sink holes and Internal intrusion containment.

UNIT-III: TRAFFIC THREAT ASSESSMENT (Periods:12)

Traffic Threat Assessment: Assumptions, First cuts, looking for odd traffic, Inspecting individual services through NTP, ISAKMP, ICMP, Secure shell, WhoIs, LDAP, other ports.

Network Incident Response: Preparation for network incident response, Secure CSIRT communication, Intruder Profiles, Incident Detection Methods, Network First Response, Network-Centric General Response and Remediation.

UNIT-IV: NETWORK FORENSICS**(Periods:10)**

Collecting network traffic as evidence, protecting and preserving network based evidence, Analyzing network based evidence, presenting and defending conclusions.

Traffic Threat Assessment Case Study, Malicious Bots: IRC bots, communication and identification, server and control channels, exploitation and bot admin.

UNIT-V: INTRUSION PREVENTION OVERVIEW**(Periods:12)**

Intrusion Prevention Overview, Signatures and Actions: Types, Triggers and actions, Operational Tasks: deploying & configuring IPS devices and applications, Monitoring IPS activities, Securing IPS communications, Security in Depth: Defense in depth, internal attack against a Management server and the future of IPS.

Total Periods:56**TEXT BOOKS:**

1. Richard Bejtlich, *"Extrusion Detection: Security Monitoring for Internal Intrusions,"* First Edition. Pearson Education, New Delhi, 2004.
2. Earl Carter, Jonathan Hogue, *"Intrusion Prevention Fundamentals,"* First Edition, Pearson Education, New Delhi, 2002.

REFERENCE BOOKS:

1. Carl Endorf, Eugene Schultz and Jim Mellander, *"Intrusion Detection and Prevention,"* McGraw-Hill, 2004
2. Stephen Northcutt, Judy Novak, *"Network Intrusion Detection,"* New Riders Publishing, Third Edition, 2002

SREE VIDYANIKETHAN ENGINEERING COLLEGE (Autonomous)

Department of Computer Science and Engineering

I M.Tech (CN&IS). II-Semester

(16MT26302) NETWORK PROGRAMMING

Int. Marks	Ext. Marks	Total Marks	L	T	P	C
40	60	100	4	-	-	4

PRE-REQUISITES:

Courses on "Computer Networks" and "Unix Programming"

COURSE DESCRIPTION:

Concepts of Unix Standards; Protocol Usage by common internet application; Elementary TCP Sockets; Handling server process termination; crashing and rebooting; IPV6 socket options; Interface with UDP; Function and IPV6 support; I/O multiplexing IPC creating and opening channels, permissions; Terminal Modes, Remote login overview;

COURSE OUTCOMES:

After successful completion of this course, the students will be able to:

CO1: Gain knowledge in

- Basic concepts of UNIX standards, networks and socket functions.
- TCP and UDP socket API and related functions.
- DNS and address conversions.
- I/O Multiplexing, IPC and RPC.

CO2: Analyze the key protocols that support the Internet and several common programming interfaces for network communication.

CO3: Solve I/O Multiplexing issues using TCP socket programming.

CO4: Design client server architecture by developing new TCP and UDP socket functions.

CO5: Apply appropriate techniques and tools to implement algorithms for modern network architectures.

DETAILED SYLLABUS:

UNIT I- INTRODUCTION TO NETWORK PROGRAMMING

(13 periods)

OSI model, UNIX standards, TCP and UDP & TCP connection establishment and Termination, SCTP Association Establishment and Termination, Port Numbers, TCP Port numbers and Concurrent Servers, Buffer sizes and limitation, standard internet services, Protocol usage by common internet application.

Sockets: Socket Address structures, value result arguments, Byte ordering and manipulation function and related functions Elementary TCP sockets - Socket, connect, bind, listen, accept, fork and exec function, concurrent servers. Close function and related function.

UNIT II – TCP AND UDP SOCKETS (12 periods)

TCP client server: Introduction, TCP Echo server functions, Normal startup and Termination, POSIX signal handling, Handling SIGCHLD signals, wait and wait pid functions, Connection Abort before accept returns, server process termination, Crashing and Rebooting of server host shutdown of server host.

Elementary UDP sockets: Introduction UDP Echo server function, Verifying Received Responses, Server not running, lost datagram, summary of UDP example, Lack of flow control with UDP, determining outgoing interface with UDP.

UNIT III –I/O MULTIPLEXING AND SOCKET OPTIONS (10 periods)

I/O Models, select function, shutdown function, poll function, pselect function, TCP Echo server, getsockopt and setsockopt functions. Socket states, Generic socket option IPV6 socket option ICMPV6 socket option IPV6 socket option and TCP socket options, fcntl function.

UNIT IV –ELEMENTARY NAME AND ADDRESS CONVERSIONS (8 periods)

DNS, getxxx() related functions, Resolver option, Function and IPV6 support, uname function, Obsolete IPV6 Address Lookup Functions, and other networking information.

UNIT V – IPC AND REMOTE PROCEDURE CALL (10 periods)

IPC: Posix IPC, File and record locking, Pipes, FIFOs streams and messages, Name spaces, system IPC, Message queues, Semaphores and Shared Memory. Introduction to RPC and Transparency Issues, Sun RPC, dup, dup2 System calls.

Total Periods: 55

TEXT BOOKS:

1. W.Richard Stevens, "UNIX Network Programming: The Sockets Networking API- 1," 3ed, PHI, 2010.
2. W.Richard Stevens, "UNIX Network Programming Inter process Communications," 2ed, PHI, 2004.

REFERENCE BOOKS:

1. W.Richard Stevens, "UNIX Network Programming," 2ed, Pearson Education,2008.
2. M.J. Rockkind, "Advanced Unix Programming," 2ed, Pearson Education, 2005.

SREE VIDYANIKETHAN ENGINEERING COLLEGE (Autonomous)
Department of Computer Science and Engineering
I M.Tech (CN&IS). II-Semester
(16MT10506) INFORMATION RETRIEVAL SYSTEMS
(Professional Elective-2)

Int. Marks	Ext. Marks	Total Marks	L	T	P	C
40	60	100	4	--	--	4

PRE-REQUISITE:

A Course on "Database Management Systems"

COURSE DESCRIPTION:

Concepts of Information retrieval Systems; Indexing and data structures; indexing, Document and term clustering; user search techniques; Text search algorithms, information system Evaluation;

COURSE OUTCOMES:

After successful completion of this course, students will be able to:

CO1 : Acquire knowledge in fundamental concepts of

- Information Retrieval System capabilities
- Data Structures
- Indexing and Search Algorithms

CO2: Analyze concepts of Database, Data Warehouses of real time applications related to Document Store, Document data warehouses, judicial, biomedical, scientific documents.

CO3: Solve complex search problems like ranking , weighted ,software text searches by implementing A* Search, Zipf and Information retrieval frame work

CO4: Initiate research to identify and develop algorithms for indexing, clustering and searching

CO5: Create and apply online Information Retrieval Systems like search engines.

DETAILED SYLLABUS:

UNIT I: INTRODUCTION TO INFORMATION RETRIEVAL SYSTEM (periods: 11)

Definition, Objectives, Functional Overview, Relationship to DBMS, Digital libraries and Data Warehouses

Information Retrieval System Capabilities: Search, Browse.

UNIT II: INDEXING AND DATA STRUCTURES (periods: 11)

Objectives of Indexing, Indexing Process, Automatic Indexing

Data Structures: Introduction to Data Structures, Stemming Algorithms, Inverted file structures, N-gram data structure, PAT data structure, Hypertext data structure.

UNIT III: AUTOMATIC INDEXING AND CLUSTERING (periods: 10)

Classes of automatic indexing, Statistical indexing, Natural language, Concept indexing. **Document and Term Clustering:** Introduction to

Clustering, Thesaurus generation, Manual clustering, Automatic Term Clustering, Hierarchy of clusters.

UNIT IV: USER SEARCH TECHNIQUES (periods: 12)

Search statements and binding, Similarity measures and ranking, Relevance feedback, Selective dissemination of information search, weighted searches of Boolean systems.

UNIT V: TEXT SEARCH ALGORITHMS (periods: 11)

Introduction to Text Search Techniques, Software text search algorithms, Hardware text search systems.

Information System Evaluation: Introduction to Information System Evaluation, Measures used in system evaluation.

Total No. of periods (55)

TEXT BOOK:

1. Kowalski, Gerald, Mark T Maybury Kluwer, *"Information Storage and Retrieval Systems: Theory and Implementation"*, 2ed, Springer, Seventh Indian reprint 2 , 2013...

REFERENCE BOOKS:

1. Ricardo Baeza-Yates ,*"Modern Information Retrieval"* , Pearson Education, 2007
2. David A Grossman and Ophir Frieder, *"Information Retrieval: Algorithms and Heuristics"*, 2ed, Springer, 2012.

SREE VIDYANIKETHAN ENGINEERING COLLEGE (Autonomous)
Department of Computer Science and Engineering
I M. Tech. (CN&IS) II-Semester
(16MT26304) COMPUTER FORENSICS
(Professional Elective-2)

Int. Marks	Ext. Marks	Total Marks	L	T	P	C
40	60	100	4	--	--	4

PRE-REQUISITES:

A Course on "Information Security"

COURSE DESCRIPTION:

Concepts of computer forensic technologies and cybercrime; Evidence collection and data seizure; Initial Response and Forensic Duplication; Forensic Data Analysis and Validation; Processing crimes and incident scenes; Mobile Device Forensics, Network forensics and E-Mail Investigations

COURSE OUTCOMES:

After successful completion of this course, students will be able to:

CO1: Acquire knowledge in

- Computer Forensic Fundamentals and Technologies
- Evidence and Data Capture and Computer Forensic Analysis
- Law Enforcement crime and incident scenes

CO2: Analyze and validate forensic data related to mobile devices, E-Mails.

CO3: Provide solutions for a wide range of forensic problems like attack on routers, E-Mail crimes.

CO4: Conduct research and contribute in groups for the development of new forensics tools.

CO5: Create and apply appropriate forensic tools, techniques to capture the evidence and investigate crimes

DETAILED SYLLABUS

UNIT – I: OVERVIEW OF COMPUTER FORENSICS TECHNOLOGY AND CYBERCRIME (10 periods)

Computer Forensics Fundamentals: Introduction to computer Forensics, Use of computer Forensics in Law Enforcement, Computer Forensics Assistance to Human Resources/Employment Proceedings, Computer Forensics Services, Benefits of Professional Forensics Methodology, Steps taken by Computer Forensics Specialists.

Types of Computer Forensics Technologies: Types of Military Computer Forensic Technology, Types of Law Enforcement- Computer Forensic Technology, Types of Business Computer Forensic Technology.

Introduction to Cybercrime: Introduction to Cybercrime, Cybercrime and Information Security, Cybercriminals, Classification of Cybercrimes, Cyber Detectives, Tools: Dig-x/nslookup, Whois, Ping.

UNIT – II: COMPUTER FORENSICS EVIDENCE AND (10 periods)

Data Recovery: Data back-up and Recovery, Role of Back-up in Recovery, Data-Recovery solution.

Evidence Collection and Data Seizure: Importance of Collect Evidence, Collection Options ,Obstacles, Types of Evidence, The Rules of Evidence, Volatile Evidence, General Procedure – Collection and Archiving, Methods of Collection, Artifacts, Collection Steps, Controlling Contamination: The Chain of Custody.

UNIT – III: INITIAL RESPONSE AND FORENSIC DUPLICATION (12 periods)

Initial Response & Volatile Data Collection from Windows system - Initial Response & Volatile Data Collection from Unix system. Forensic duplication: Forensic Duplicates as Admissible Evidence, Forensic Duplication Tool Requirements, Creating a Forensic Duplicate/Qualified Forensic Duplicate of a Hard Drive, Live Data Collection for Systems (Windows & Unix).

UNIT -IV: COMPUTER FORENSIC ANALYSIS (12 periods)

Data Analysis and Validation: Determining what data to collect and analyze, Validating forensic data, Addressing data, Hiding techniques, Performing remote acquisitions.

Processing Crime and Incident Scenes: Identifying digital evidence, Collecting evidence in private-sector incident scenes, Mobile Forensic Unit, Processing law enforcement crime, Preparing for a search, Seizing Digital Evidence at the Scene, Storing Digital Evidence.

UNIT – V: FORENSICS IN VARIOUS AREAS (10 periods)

Cell Phone & Mobile Device Forensics :Understanding Mobile Device Forensics, Acquisition Procedures for Cell Phones and Mobile Devices, Tool kits for hand-held device forensics like EnCase, Device Seizure and PDA Seizure.

Network Forensics: Overview, Performing Live Acquisitions, Developing Standard Procedure for Network Forensics, Investigating Routers, Network Tools.

E-Mail Investigation: Exploring the role of E-Mail in investigations, Investigating E-Mail Crimes and Violations.

Total periods: 54

TEXT BOOKS:

1. John R.Vacca, "*Computer Forensics, Computer Crime Investigation*" 1ed, Firewall Media, New Delhi ,2009.
2. Nelson, Amelia Phillips, Christopher Steuart, "*Computer Forensics and Investigations*", 4ed, Cengage Learning, 2009.

REFERENCE BOOKS:

1. Sunit Belapure, Nina Godbole, "*Cyber Security: Understanding Cyber Crimes, Computer Forensics And Legal Perspectives*", 1ed, Wiley India Pvt Ltd, 2011.
2. Kevin Mandia, Chris Prorise, "*Incident Response and Computer Forensics*", 2ed, McGraw-Hill Osborne Media, 2003
3. Eoghan Casey, "*Handbook Computer Crime Investigation's Forensic Tools and Technology*", 1ed, Academic Press, 2001.
4. Peter Stephenson, Keith Gilbert, "*Investigating Computer Related Crime*", 2ed, CRC Press, 2004.

**M. Tech (CN&IS) II-Semester
(14MT26302) COMPUTER FORENSICS**

Int. Marks	Ext. Marks	Total Marks	L	T	P	C
40	60	100	4	--	--	4

PRE-REQUISITES: *Courses on "Computer Networks" and "Information Security"*

COURSE DESCRIPTION:

Overview of Computer forensics and cyber crime; Evidence collection and data seizure; Data Analysis and validation; Mobile device forensics; Cyber crime, cyber laws and forensic report generation

COURSE OUTCOMES:

On successful completion of this course the students will be able to:

- CO1. Gain advanced knowledge in
- Computer Forensic Fundamentals and Technologies
 - Evidence and Data Capture and Computer Forensic Analysis
 - Application of forensics in various areas and Cybercrime and Cyber Laws
- CO2. Analyze the strengths and weaknesses of cyber laws in terms of global and Indian context.
- CO3. Develop skills to invent forensic tools and to analyze the crime.

UNIT-I: OVERVIEW OF COMPUTER FORENSICS TECHNOLOGY AND CYBERCRIME (Periods:11)

Computer Forensics Fundamentals-Introduction to computer forensics, Use of computer forensics in Law Enforcement, Benefits of professional forensics methodology, Steps taken by computer forensics specialists.

Types of Computer Forensics Technologies-Types of Military computer forensic technology, Types of law enforcement, Computer forensic Technology, Types of Business Computer Forensic Technology

Introduction to Cybercrime: Introduction to Cybercrime, Cybercrime and Information Security, Cybercriminals, Classification of Cybercrimes.

UNIT – II: COMPUTER FORENSICS EVIDENCE AND CAPTURE (Periods:12)

Evidence Collection and Data Seizure: Collect Evidence, Collection Options, Types of Evidence, The Rules of Evidence, Volatile Evidence, General Procedure – Collection and Archiving, Methods of Collection, Controlling Contamination: The Chain of Custody, Evidence Handling and Presentation in Court of Law, Incident and Incident Response, Initial Response and Forensic Duplication, E-Mail Investigations- Exploring the Role of E-Mail in Investigations, Investigating E-Mail Crimes and Violations, Live Data Collection from Systems (Windows & Unix)

UNIT -III: COMPUTER FORENSIC ANALYSIS**(Periods:12)**

Data Analysis and Validation: Determining what data to collect and analyze, Validating forensic data, Addressing data, hiding techniques, performing remote acquisitions.

Processing Crime and Incident Scenes: Identifying digital evidence, collecting evidence in private-sector incident scenes, Mobile Forensic Unit, Processing law enforcement crime, Preparing for a search, Seizing Digital Evidence at the Scene, Storing Digital Evidence

UNIT – IV: FORENSICS IN VARIOUS AREAS**(Periods:12)**

Cell Phone & Mobile Device Forensics : Understanding Mobile Device Forensics, Acquisition Procedures for Cell Phones and Mobile Devices, Toolkits for Hand-Held device Forensics like EnCase, Device Seizure and PDA Seizure, Forensic Card Reader, Cell Seizure, MOBILedit!, Forensic SIM.

Network Forensics: Overview, Performing Live Acquisitions, Developing Standard Procedure for Network Forensics, Investigating Routers, Network Tools.

UNIT – V: CYBERCRIME IN LEGAL PERSPECTIVE AND FORENSIC REPORT GENERATION**(Periods:11)**

Cyber Law Basics: Need for Cyber laws, The Indian Context, Cybercrime and the Indian ITA 2000, A Broad View on cybercrime Law scenario in the Asia-Pacific Region.

Importance of Cyber Security- Roles and Responsibilities of Engineers in offering Cybersecurity, Cybercrime Investigation and Litigation, Assurance and Compliance Security Audit.

Report Writing for Investigations: Guidelines for writing Report, Generating Report Findings with Forensics Software Tools.

Total Periods:58**TEXT BOOKS:**

1. John R.Vacca, "Computer Forensics, Computer Crime Investigation," First Edition, New Delhi, Firewall Media, 2009
2. Nelson, Amelia Phillips, Christopher Steuart, "Computer Forensics and Investigations," Fourth Edition, Cengage Learning, 2009.

REFERENCE BOOKS:

1. Sunit Belapure, Nina Godbole, "Cyber Security: Understanding Cyber Crimes, Computer Forensics and Legal Perspectives," First Edition, Wiley India Pvt Ltd, 2011.
2. Kevin Mandia, Chris Prorise, "Incident Response and Computer Forensics," Second Edition, McGraw-Hill Osborne Media, 2003
3. Eoghan Casey, "Handbook Computer Crime Investigation's Forensic Tools and Technology," First Edition, Academic Press, 2001
4. Peter Stephenson, Keith Gilbert, "Investigating Computer Related Crime," Second Edition, CRC Press, 2004

SREE VIDYANIKETHAN ENGINEERING COLLEGE (Autonomous)
Department of Computer Science and Engineering
I M Tech (CN&IS) II-Semester
(16MT26305) DATABASE SECURITY
(Professional Elective-2)

Int. Marks	Ext. Marks	Total Marks	L	T	P	C
40	60	100	4	--	--	4

PRE-REQUISITES:

A course on "Database Management Systems"

COURSE DESCRIPTION:

Explore database access controls; data obscurity and physical database security; Password Policies, Privileges; fraud detection through the use of audit tables & triggers and obscurity through the use of encryption; views & virtual private databases.

COURSE OUTCOMES:

After successful completion of this course, students will be able to:

CO1: Acquire knowledge in

- Information System Security
- Design of Secure Databases.
- Database System Models and Applications.
- Need for database security architecture.

CO2: Analyze fundamental database security threats, vulnerabilities and associated risks.

CO3: Implement specific database security solutions that include: access controls, audit/control and obscurity (encryption, views, and VPDs) mechanisms.

CO4: Create database security architecture, database user roles using SQL Server

CO5: Conduct research on establishment of strong passwords and manage th resources through database audit/access controls.

CO6: Recognize database security issues, implementation methods to database security mechanisms and strategies in life- long learning.

DETAILED SYLLABUS:

UNIT-I: SECURITY ARCHITECTURE AND OPERATING SYSTEM SECURITY FUNDAMENTALS (11 periods)

Security Architecture: Introduction, Security, Information Systems, Database Management Systems, Information Security, Information Security Architecture, Database Security, Asset Type and their Values, Security Methods.

Operating System Security Fundamentals: Operating System Security Environment, Components, Authentication Methods, user Administration, Password Policies, Vulnerabilities.

UNIT-II: ADMINISTRATION OF USERS AND PROFILES, PASSWORD POLICES, PRIVILEGES (10 periods)

Administration of Users: Introduction, Documentation of User Administration, Operating System Authentication, Creating Users, Creating SQL Server User, Removing Users, Modifying Users, Default Users, Remote Users, Database Links, Linked Servers, Remote Servers, Practices for Administrators and Managers.

Profiles, Password Polices, Privileges: Defining and Using Profiles, Designing and Implementing Password Polices, Granting and Revoking User Privileges.

UNIT-III: SECURITY MODELS AND VIRTUAL PRIVATE DATABASES (11 periods)

Database Application Security Models: Introduction, Types of Users, Security Models, Application Types, Application Security Models.

Virtual Private Databases: Introduction, Overview of VPD, Implementing VPDs, Implementing Oracle VPD, Viewing VPD Policies and Application Context Using the Data Dictionary and Policy Manager, Implementing Row-and Column level Security with SQL Server .

UNIT-IV: DATABASE SECURITY DESIGN

Secure DBMS Design: Introduction, Security mechanisms in DBMSs, Secure DBMS architectures.

Design of Secure Databases: Preliminary Analysis, Requirement Analysis and Security Policy Selection, Conceptual Design, Logical Design, Physical Design, Implementation of Security Mechanisms, Verification and Testing.

UNIT-V: DATA AUDITING AND AUDITING DATABASE ACTIVITIES (10 periods)

Application Data Auditing: Introduction, DML Action Auditing Architecture, Oracle Triggers, SQL Server Triggers, Fine-grained Auditing with Oracle, DML Statement Audit Trail, Auditing Application Errors with Oracle.

Auditing Database Activities: Using Oracle Database Activities, Creating DLL Triggers with Oracle, Auditing Database Activities with Oracle, Auditing Server Activity with Microsoft SQL Server 2000, Implementing AQL Profiler, Security Auditing with SQL Server, SQL Injection

Total Periods: 54

TEXT BOOKS:

1. Hassan A. Afyouni, *"Database Security and Auditing: Protecting Data Integrity and Accessibility,"* CENGAGE Learning, New Delhi, 2006.
2. S. Castano, M. Fugini, G. Martella, P. Samarati, *"Database Security,"* Addison-Wesley, New York, 1994

REFERENCE BOOKS:

1. Ron Ben Natan, *"Implementing Database Security and Auditing,"* U.S.A: Elsevier Digital Press, 2005.
2. Michael Gertz, SushilJajodia, *"Handbook of Database Security: Applications and Trends,"* New York: Springer, 2008.

**M Tech (CN&IS) I-Semester
(14MT16303) DATABASE SECURITY (Elective-1)**

Int. Marks	Ext. Marks	Total Marks	L	T	P	C
40	60	100	4	--	--	4

PRE-REQUISITE: A course on "Database Management Systems"

COURSE DESCRIPTION:

Database and information security architecture and operating systems security; User Administration; Database application security models and virtual private databases; auditing application data and database activities; case studies

COURSE OUTCOMES:

On successful completion of this course the students will be able to:

- CO1. Gain knowledge in
- Information System Security
 - Design of Secure Software
 - Database System Models and Applications.
 - Need for database security architecture.
- CO2. Analyze fundamental database security threats, vulnerabilities and associated risks.
- CO3. Implement secure User accounts, and VPDs using database management system technologies
- CO4. Create database security architecture.

UNIT-I: SECURITY ARCHITECTURE AND OPERATING SYSTEM SECURITY FUNDAMENTALS (Periods:11)

Security Architecture-Introduction, Security, Information Systems, Database Management Systems, Information Security, Information Security Architecture, Database Security, Asset type and their Values, Security Methods.

Operating System Security Fundamentals-Operating System Security Environment, Components, Authentication methods, User administration, Password policies, Vulnerabilities.

UNIT-II: ADMINISTRATION OF USERS AND PROFILES, PASSWORD POLICIES, PRIVILEGES, AND ROLES (Periods:11)

Administration of Users-Introduction, Documentation of user administration, Operating system authentication, Creating users, Creating SQL server users, Removing users, Modifying users, Default users, Remote users, Database links, Linked servers, Remote servers, Practices for administrators and Managers, Best practices.

Profiles, Password Policies, Privileges, and Roles: Defining and Using Profiles, Designing and Implementing Password Policies, Granting and Revoking User Privileges Creating.

UNIT-III: SECURITY MODELS AND VIRTUAL PRIVATE DATABASES (Periods:11)

Database Application Security Models-Introduction, Types of users, Security Models, Application Types, and Application security models.

Virtual Private Databases-Introduction, Overview of VPD, Implementing VPDs, Implementing oracle VPD, Viewing VPD policies, VPD application context using the Data Dictionary and Policy Manager, Implementing Row-and Column level Security with SQL Server and Database Auditing Models

UNIT-IV: DATA AUDITING AND AUDITING DATABASE ACTIVITIES

(Periods:12)

Application Data Auditing-Introduction, DML action auditing architecture, Oracle triggers, SQL server triggers, Fine-grained auditing with oracle, DML statement audit trail, auditing application errors with oracle.

Auditing Database Activities-Using oracle database activities, Creating DLL triggers with oracle, Auditing database activities with oracle, Auditing server activity with Microsoft SQL server 2000, Implementing AQL profiler, Security auditing with SQL server

UNIT-V: CASE STUDIES

(Periods:10)

Security and Auditing Project Cases: SQL Injection, Develop an Online Database, Taking Care of Payroll, Tracing Town Contracts and Database Changes, Developing a Secured Authorization Repository.

Total Periods:55

TEXTBOOKS:

1. Hassan A. Afyouni, "Database Security and Auditing: Protecting Data Integrity and Accessibility," Cengage Learning, New Delhi, 2006.
2. S. Castano, M. Fugini, G. Martella, P. Samarati, "Database Security," Addison-Wesley, New York, 1994

REFERENCE BOOKS:

1. Ron Ben Natan, "Implementing Database Security and Auditing," U.S.A: Elsevier Digital Press, 2005.
2. Michael Gertz, SushilJajodia, "Handbook of Database Security: Applications and Trends," New York: Springer, 2008.

SREE VIDYANIKETHAN ENGINEERING COLLEGE (Autonomous)
Department of Computer Science and Engineering
I M. Tech (CN&IS). II-Semester
(16MT26306)SOCIAL NETWORKS
(Professional Elective-2)

Int. Marks	Ext. Marks	Total Marks	L	T	P	C
40	60	100	4	--	--	4

PRE-REQUISITES:

A Course on "Computer Networks"

COURSE DESCRIPTION:

Concepts of Tweet rank model; Rich Media Communications patterns; Data Pre-Processing; Challenges of DOSN; Web accessibility analysis; Collaborative tagging; Visualization and Applications of Social Networks

COURSE OUTCOMES:

CO1: Gain knowledge on

- Social Media Analysis
- Mining and Privacy.
- Visualization and Applications of Social Networks.

CO2: Analyze the mining techniques, social network Infrastructures and Communities.

CO3: Apply the Baye's Conditional Probabilities technique in the real world applications of social networks.

CO4: Initiate research to identify solutions for security and privacy in social networks.

CO4: Develop effective communication among peers in the area of Social Networks.

CO5: Acquire professional code of conduct and social responsibility to contribute for development of society.

DETAILED SYLLABUS:

UNIT I Social Media Analysis and Organization (10 periods)

Social Network Analysis: History, Concepts, and Research, Analysis of Social Networks by Tensor Decomposition, Analyzing the Dynamics of Communication in Online Social Networks, Qualitative Analysis of Commercial Social Network Profiles.

UNIT II Social Media Mining and Search (11 periods)

Discovering Mobile Social Networks by Semantic Technologies, Online Identities and Social Networking, Detecting Communities in Social Networks, Concept Discovery in Youtube.com Using Factorization Method, Discovering Communities from Social Networks: Methodologies and Applications

UNIT III Social Network Infrastructures and Communities

(11 periods)

Decentralized Online Social Networks, Multi-Relational Characterization of Dynamic Social Network Communities, Accessibility Testing of Social Websites, Understanding and Predicting Human Behavior for Social Communities

UNIT IV Privacy in Online Social Networks (11 periods)

Managing Trust in Online Social Networks, Security and Privacy in Online Social Networks, Investigation of Key-Player Problem in Terrorist Networks Using Bayes Conditional Probability, Security Requirements for Social Networks in Web 2.0

UNIT V Visualization and Applications of Social Networks (12 periods)

Visualization of Social Networks, Novel Visualizations and Interactions for Social Networks Exploration, Applications of Social Network Analysis, Online Advertising in Social Networks

Total Periods: 55

TEXT BOOK:

1. Borko Furht, "Handbook of Social Network Technologies and Applications", 1ed, Springer, 2010.

REFERENCE BOOKS:

1. Peter Mika, "Social Networks and the Semantic Web", 1ed, Springer, 2007
2. John Lovett, "Social Media Metrics Secrets", Wiley India Private Limited, 2011.

SREE VIDYANIKETHAN ENGINEERING COLLEGE (Autonomous)

Department of Computer Science and Engineering

I M. Tech (CN&IS) – II Semester

(16MT20531) CLOUD COMPUTING & BIG DATA ANALYTICS LAB

Int. Marks	Ext. Marks	Total Marks	L	T	P	C
50	50	100	--	--	4	2

PRE-REQUISITES:

Course on "Cloud Computing" and "Operating Systems"

COURSE DESCRIPTION:

Hands-on experience on creating Virtual machines on Windows and Linux platforms, Development of Service based web applications & their deployment and Mobile app development, Designing and implementing Hadoop cluster.

COURSE OUTCOMES:

After successful completion of this course , students will be able to:

- CO1: Demonstrate hands-on experience on Virtualization models, Cloud Environment and Hadoop cluster setup.
- CO2: Analyze the given experiment and measure the performance of services and datasets.
- CO3: Apply API development skills in web applications for Cloud deployment and develop solutions for real time applications using Hadoop.
- CO4: Devise virtual environments based on virtualization techniques and processing huge amount of data using Big data tools
- CO5: Develop written and oral communications in preparing and presenting reports.

LIST OF PRACTICAL EXERCISES:

1. Create Virtual machines with given set of configuration on Hyper-V, Ubuntu 14 LTS OS, with 2 GB RAM and 200 GB HDD". (IaaS)
2. Create Virtual machines with given set of configuration on Ubuntu OS: "Windows 7 OS with 4 GB RAM and 500 GB HDD". (IaaS)
3. Develop a Design document for a web application, to perform operations based on service calls and to be deployed on cloud environment. (Design Doc)
4. Develop a web application for performing Calculator operations by selecting relevant services. Deploy it on cloud platform. (SaaS)
5. Develop a HTTPS web application with social media interfaces (Facebook / Twitter / Instagram / Google+ APIs). (SaaS)
6. Develop a mobile app on Google App Engine for uploading a resume into a website, collaborated with Drop box. The resume should be encrypted. (PaaS)
7. Develop a service call to run on Drop box resumes for picking the resumes of given skill set. (PaaS)

- a. 6+ years of Exp in Java Development.
 - b. 10 years of experience in Automation Testing.
 - c. 15+ years of Managerial experience with technical background.
 - d. 5-7 years of on-site experience in .NET support and programming.
- 8. Install and run Hadoop using Single node Cluster.
 - 9. Install and run Hadoop using Multi node cluster
 - 10. Write a program to count words in a program using map and reduce functions and Hadoop.
 - 11. Illustrate installation and configuring of Hive.

REFERENCE BOOKS:

- 1: Ivanka Menken and Ivanka Menken, "*Cloud Computing Virtualization Specialist Complete Certification Kit - Study Guide Book*," 1ed, Emereo Pty. Ltd., 2009.
- 2: Barrie Sosinsky, "*Cloud Computing Bible*," 1ed, Wiley India Pvt Ltd, 2011.
- 3: Tom White, "*Hadoop: The Definitive Guide*," 3ed, O'REILLY Publications, 2012.

**M. Tech (CN&IS) II-Semester
(14MT26322) WEB PROGRAMMING AND CLOUD COMPUTING
LABORATORY**

Int. Marks	Ext. Marks	Total Marks	L	T	P	C
25	50	75	-	-	4	2

PRE-REQUISITES: Courses on “Web Programming” and “Cloud Computing”

COURSE DESCRIPTION:

Develop and implement dynamic web applications on contemporary and social issues using HTML, CSS, JS and PHP technologies.

Hands on practice in using Visual Modeling Tools and design real time case studies such as Automated Teller Machine (ATM), Online Ticket Reservation for Railways, A Point-of-Sale (POS) System, A Multi-Threaded Airport Simulation, Hospital Management System, Unified Library Application, and Online Shopping.

COURSE OUTCOMES:

On successful completion of this course the students will be able to:

- CO1. Gain Knowledge on the real time applications of Cloud computing and to design web pages using HTML, CSS and JS.
- CO2. Analyze XML files using DTD parser.
- CO3. Use Dreamweaver and Notepad++ for designing web pages and generating dynamic content. And Cloud Computing tools Windows Azure, Sales Force, and VMware
- CO4. Recognize the need of Cloud Computing, Software Testing and can engage in lifelong learning by incorporating best practices of them
- CO5. Develop websites for self-development and for promoting awareness among the community in societal and environmental issues.

Laboratory Exercises:

Web Programming:

1. Create an HTML web page with at least the following features:
Keywords & description meta tags, title, Page formatting, including a background color *and* picture, a non-default text color, and non-default text and link colors, A horizontal rule, At least three levels of headers, Text formatting, including specifying a non-default font as well as centered, bold, italics, subscript, superscript, and strikethrough, A three-level bulleted list and a two-level numbered list, At least two external links, with one a text link and one an image link, Three internal “bookmark” links – that is, a link to further down on the current page, A relative link to an image in a different directory than the directory in which your current HTML page resides, An image with a non-standard-width border in a non-standard color. The image should appear off to the right side of the page, An image map with at least three links, A table that includes at least three rows, two cells in each row, two colspan attributes, and one rowspan attribute. Put a background color on the entire table, a different

background color on one cell, and a background image on one entire row of the table.

2. Create an HTML web page with JavaScript for the following problem:
Get two input numbers from an HTML form. On submit, call a function to edit them to make sure that they are within the range of 1-100. If not, display an error message and set focus to the field in error. If the entered numbers are valid, add the two numbers together and display the total in an alert box. Pop up a prompt box to get a third number and edit it to make sure it's in the range of 1 to 5. Multiply the original total (from the two input boxes) by this third number. Store the result in a cookie and then automatically open a second page to display the cookie that you saved on the prior page.
3.
 - a. Write an XML file which will display the Book information which includes the following:
 - 1) Title of the book
 - 2) Author Name
 - 3) ISBN number
 - 4) Publisher name
 - 5) Edition
 - 6) Price
 - b. Write a Document Type Definition (DTD) to validate the above XML file. Display the XML file as follows:
The contents should be displayed in a table. The header of the table should be in color GREY. And the Author names column should be displayed in one color and should be capitalized and in bold. Use your own colors for remaining columns. Use XML schemas XSL and CSS for the above purpose. Note: Give at least for 4 books. It should be valid syntactically. Hint: You can use some xml editors like XML-spy
4. Write PHP Script to demonstrate
 - a. String processing in PHP
 - b. File uploading
 - c. Sessions and Cookies
5. Write PHP Script that takes user input data(Personal Information like registration to a website) in a form and validates it and write the data into the database

Sales Force:

6. Using Salesforce CRM,
 - a. Create a Warehouse Application.
 - b. Add Relationships to it.
 - c. Apply formulas and Validation Rules on the records of a data.
 - d. Creation of Dash Boards.
 - e. Create an approval process for it and generate reports.

MS-Azure:

7. Create and Configure Virtual Machines using MS-Azure.
8. Create and configure SQL server in an Azure VM
9. Web hosting using MS-Azure.

VMware:

10. Illustrate forms of virtualization on VMware.

SREE VIDYANIKETHAN ENGINEERING COLLEGE (Autonomous)
Department of Computer Science and Engineering
I M. Tech. (CN&IS) -II Semester
(16MT26331) WIRELESS NETWORKS LAB

Int. Marks	Ext. Marks	Total Marks	L	T	P	C
50	50	100	-	-	4	2

COURSE DESCRIPTION:

This course introduces hands-on experience in designing and implementing wireless networking models.

COURSE OUTCOMES:

On successful completion of this course the students will be able to:

CO1. Gain practical knowledge on wireless network simulation.

CO2. Analyze performance measures of multi-hop wireless network models.

CO3. Design wireless networking models and validate networking protocols.

CO4. Compare and Contrast performance measures of new networking models.

CO5. Develop simulation models for wireless networking by using QUALNET.

List of Exercises in *Wireless Networks*:

Exercise Number	Description	No. of Slots required
1	Consider a Wireless channel with data rate 2Mbps and transmit data more than the channel capacity. Simulate TCP-SACK (Selective Acknowledgement Protocol) Protocol to retransmit the lost packets.	2
2	Given a wireless network with four channels, each with a frequency of 2.4Ghz, simulate ALOHA multiple access technique to access the channels.	1
3	The maximum achievable throughput in the aloha protocol is low because of more number of collisions. Simulate Carrier Sense Multiple Access (CSMA) Protocol to reduce the number of collisions.	1

Table-1

PARAMETER	VALUE
Simulation time	60 Sec
Simulation area	700m X 700m
Maximum number of packets	50
Packet rate	5 packets/sec
Traffic size	CBR
Number of channels	3
Node movement model	Random Way Point

Number of nodes	15
Mobility of nodes	Yes
Network interface type	Wireless
MAC type	802.11
Bandwidth	10 Mbps

- | | | |
|---|---|---|
| 4 | Design a scenario using the a parameters given in table 1, Simulate Destination Sequenced Distance Vector (DSDV) Routing Algorithm for AdHoc Networks, and analyze the metrics throughput, average end to end delay, packet delivery ratio, jitter by changing the number of channels, maximum number of packets, packet rate, IPV6 and number of nodes. | 2 |
| 5 | Design a scenario using the parameters given in table 1, Simulate Ad Hoc on Demand Distance Vector (AODV) Routing Algorithm for AdHoc Networks, and analyze the metrics throughput, average end to end delay, packet delivery ratio, jitter by changing the number of channels, maximum number of packets, packet rate,IPV6, and number of nodes. | 1 |
| 6 | Design a scenario using the parameters given in table 1, Simulate Zone Routing Protocol(ZRP) Algorithm for AdHoc Networks, and analyze the metrics throughput, average end to end delay, packet delivery ratio, jitter by changing the number of channels, maximum number of packets, packet rate,IPV6, and number of nodes. | 1 |
| 7 | Design a scenario using the parameters given in table 1, Simulate Wireless Routing Protocol(WRP),a path finding algorithm for AdHoc Networks. Analyze the metrics throughput, average end to end delay, packet delivery ratio, jitter by changing the number of channels, maximum number of packets, packet rate, control overhead,IPV6and number of nodes. | 1 |
| 8 | Design a scenario using the parameters given in table 1, Simulate Fisheye Source Routing(FSR) ProtocolforAdHoc Networks, which divide each node's neighborhood to blurred zones so that the information details and accuracy is better for nodes to be nearer. Analyze the metrics throughput, average end to end delay, packet delivery ratio, jitter by | 1 |

- changing the number of channels, maximum number of packets, packet rate, control overhead, IPV6, and number of nodes.
- 9 Design a scenario using the parameters given in table 1, Simulate Clusterhead Gateway Switch Routing(CGSR) a multi-channel operation Protocol for AdHoc Networks. Analyze the metrics throughput, average end to end delay, packet delivery ratio, jitter by changing the number of channels, maximum number of packets, packet rate, control overhead, IPV6, and number of nodes. 1

Table-2

PARAMETER	VALUE
Simulation time	60 Sec
Simulation area	700m X 700m
Maximum number of packets	50
Packet rate	5 packets/sec
Traffic size	CBR
Number of channels	3
Node movement model	Random Way Point
Number of nodes	15
Mobility of nodes	Yes
Network interface type	Wireless
MAC type	802.16
Bandwidth	10 Mbps

- 10 Design a point-to-multipoint broadband wireless access scenario using the parameters given in table 2. Simulate WiMax IEEE 802.16 technology for wireless metropolitan area networks, and analyze the metrics throughput, average end to end delay, packet delivery ratio, jitter by changing the number of channels, maximum number of packets, packet rate,IPV6 and number of nodes. 1

REFERENCE BOOKS:

- 1.Dharma Prakash Agarwal, Qing-AnZeng, "Introduction to Wireless & Mobile systems," Cengage Learning, Fourth edition, 2016.
2. Theodore S. Rappaport, "Wireless Communications–Principles and Practice,"2ed, PHI, 2002

**M. Tech. (CN & IS) - I Semester
(14MT16321) WIRELESS NETWORKS & INFORMATION
SECURITY LAB**

Int. Marks	Ext. Marks	Total Marks	L	T	P	C
25	50	75	--	--	4	2

PRE-REQUISITES: Courses on “Wireless Networks” and “Information Security”

COURSE DESCRIPTION:

Develop programs for simulating wired and wireless computer network protocols and implement using network simulation tools.

Design and implement programs for Information security algorithms DES, RSA, AES, SHA and DSS using network simulators.

COURSE OUTCOMES:

On successful completion of this course the students will be able to:

CO1. Design wireless networking models and validate new protocols.

CO2. Analyze the typical performance measures of network models.

CO3. Compare and contrast various performance measures of different network models.

CO4. Develop new simulation models of protocols and mechanisms

List of Exercises in Wireless Networks:

(Total no. of Lab exercises to be performed: 05)

1. Simulate TCP-SACK (Selective Acknowledgement Protocol) Protocol for Wireless Networks
2. Simulate Pure ALOHA Protocol and Slotted ALOHA Protocol.
3. Simulate Carrier Sense Multiple Access (CSMA) Protocol.
4. Simulate Destination Sequenced Distance Vector (DSDV) Routing Algorithm for AdHoc Networks.
5. Simulate Ad Hoc on Demand Distance Vector (AODV) Routing Algorithm for AdHoc Networks.

List of Exercises in Information Security:

(Total no. of Laboratory exercises to be performed: 07)

1. Write a program to encrypt and decrypt given text using DES symmetric key algorithm.
2. Write a program to encrypt and decrypt given text in public key cryptographic system using RSA.
3. Write a program to encrypt and decrypt given text using AES algorithm with 128-bit key.
4. Write a program to implement port monitoring using NMAP.
5. Write a program to generate a Hash code for the given text using SHA-512 algorithm.
6. Create a digital signature for the given doc/pdf file using DSS algorithm.
7. Configure Firewall filters to accept/reject URLs/web content.

SREE VIDYANIKETHAN ENGINEERING COLLEGE (Autonomous)
Department of Computer Science and Engineering
M. Tech. – II Semester (CN&IS)
(16MT23810) INTELLECTUAL PROPERTY RIGHTS
(Common to all M. Tech. Programs)
(Audit Course)

Int. Marks	Ext. Marks	Total Marks	L	T	P	C
-	-	-	-	2	-	-

PRE-REQUISITES: --

COURSE DESCRIPTION:

Introduction to Intellectual Property; Trade Marks; Law of Copy Rights; Law of Patents; Trade Secrets; Unfair Competition; New Development of Intellectual Property.

COURSE OUTCOMES:

After successful completion of the course, students will be able to:

- CO1. Demonstrate in-depth knowledge on
 - Intellectual Property
 - Trade Marks & Secrets
 - Law of Copy Rights, Patents
 - New development of Intellectual Property
- CO2. Analyze the different forms of infringement of intellectual property rights.
- CO3. Solve problems pertaining to Intellectual Property Rights.
- CO4. Stimulate research zeal for patenting of an idea or product.
- CO5. Write effective reports required for filing patents.
- CO6. Develop life-long learning capabilities.
- CO7. Develop awareness of the relevance and impact of IP Law on their academic and professional lives.
- CO8. Develop attitude for reflective learning.

DETAILED SYLLABUS:

UNIT - I: Introduction to Intellectual property (Periods: 5)

Introduction, types of intellectual property, international organizations, agencies and treaties, importance of intellectual property rights.

UNIT - II: Trade Marks: (Periods: 5)

Purpose and function of trademarks, acquisition of trade mark rights, protectable matter, selecting and evaluating trade mark, trade mark registration processes.

UNIT - III: Law of copy rights: (Periods: 6)

Fundamental of copy right law, originality of material, rights of reproduction, rights to perform the work publicly, copy right ownership issues, copy right registration, notice of copy right, international copy right law.

Law of patents: Foundation of patent law, patent searching process, ownership rights and transfer

UNIT - IV: Trade Secrets: (Periods: 6)

Trade secret law, determination of trade secret status, liability for misappropriations of trade secrets, protection for submission, trade secret litigation.

Unfair competition: Misappropriation right of publicity, False advertising.

UNIT - V: New development of intellectual property:

(Periods: 6)

New developments in trade mark law; copy right law, patent law, intellectual property audits.

International overview on intellectual property, international - trade mark law, copy right law, international patent law, international development in trade secrets law.

Total Periods: 28

REFERENCE BOOKS:

1. Deborah, E. Bouchoux, *Intellectual property right*, Cengage learning.
2. Prabuddha Ganguli, *Intellectual property right - Unleashing the knowledge economy*, Tata McGraw Hill Publishing Company Ltd